

A REVIEW OF ADVANCE AUTOMATIC SENSING HEADLIGHT SYSTEM

**Aadil. C. Shaikh^{*1}, Shubham Jogdand^{*2}, Ganesh Lokhande^{*3}, Latik
Thakur^{*4}**

**¹ Assitant Professor, Department of Mechanical Engineering, Trinity Academy of Engineering, Pune,
Maharashtra, India*

**^{2,3,4} UG Students, Department of Mechanical Engineering, Trinity Academy of Engineering, Pune,
Maharashtra, India*

ABSTRACT

The highest fatal traffic accident rate occurs on curved roads at night time. In most cases, the late recognition of objects in the traffic zone plays a key role. These facts point to the importance of the role of automobile forward-lighting systems. In order to provide enhanced nighttime safety measures, this work aims to design and build a prototype of steerable headlights by adapting a conventional static headlamp with a very close eye on cost and reliability.

• INTRODUCTION

Since the static headlight provides only certain fields of illumination for the driver at night & is insufficient for curvy roads & intersections, the Advanced Front-lighting System (AFS) has been proposed by many researchers & is attracting more and more interest. More than 80 percent of all road accidents occur in darkness & bad weather - a compelling reason to strive to develop the next generation of intelligent lighting systems with multifunctional, swiveling headlights. The aim is to improve the driver's vision & thus significantly increase road safety & driving comfort. Various studies on swiveling headlamps have shown that the illumination of the driver's point of view increases by up to 300% when turning into a corner.

Automatic sensing headlights are an active safety feature designed to make nighttime or low-light driving safer by improving visibility around curves and over hills. When you drive around a curve, regular headlights continue to shine straight ahead, illuminating the side of the road and leaving the road ahead in darkness. Automatic sensing headlights, on the other hand, direct their beams according to your steering inputs, so the actual path of the vehicle is illuminated.

Similarly, when a vehicle with standard headlights crests a hill, the headlight beams temporarily point upwards towards the sky. This makes it difficult for drivers to see the road ahead and for oncoming motorists to see the

driver approaching. In contrast, automatic sensing headlights use a self-leveling system that points the light beam up or down, according to the position of the vehicle.

• **OBJECTIVE**

- To study the working of conventional head light systems.
- To design and develop a head light system which can adjust itself according to the need of road.
- To design using CATIA V5 R20 software and accordingly do the calculations and select the materials.

- Finalization of the Topic

• **METHODOLOGY**

- Gathered Review and Research Paper
- Objective and Problem Statement
- Studying the conventional mechanism of headlamp
- Studying working of sensors and programming for servo motors
- Designing the mechanism for movement of the headlamp
- CAD Diagram
- Finalization of Model
- Model and Analysis
- Results
- Summary

• **MATERIAL SELECTION**

Generally, two size of spur gear and side used in this type of casing. As we all learn in our subject Engineering Metallurgy that the Ductile Iron and Grey Cast Iron has a great vibration damping capacity other than any material. With help of some references and guidance, we are going to use ductile iron or grey cast iron as a material for casing. We are not sure of market availability. Slightly changes will happen in future.

• **MODELING AND ANALYSIS**

After all the consideration and theoretical chapters, now we leads to design. Here we done CAD Design i.e. Computer- Aided-Design which helps draw a roughly sketch using software. For 3D modelling, we selected CATIA V5 R20 Version software. CATIA is most widely used software in the world for designing the complex components.

Firstly, we have drawn a rough sketch. After that we use commands like pad, revolve, shaft, multi-section surface, split etc.

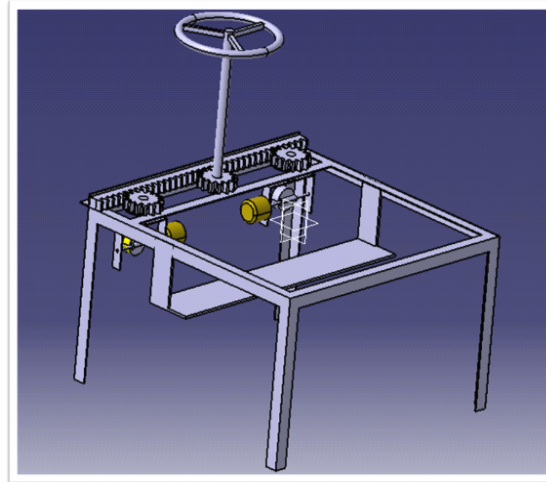

Fig 1. CATIA Model

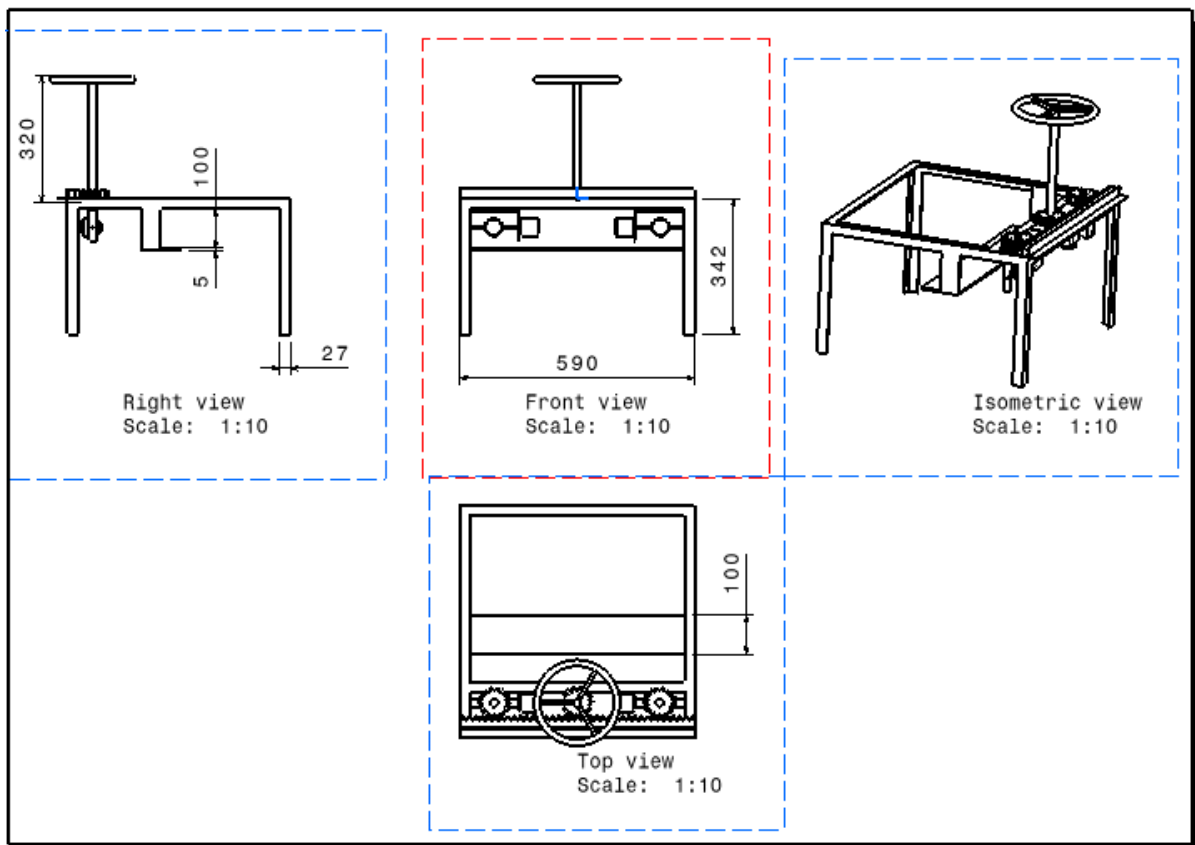

Fig 2. Drafting of Model

WORKING PROCESS

Automatic sensing headlight system operated by two methods, first is rack & pinion mechanism and second is by using of gravity sensor with Arduino UNO & servo motors. For left-right headlight movement we will use rack and pinion mechanism, and for up-down headlight movement will be adjusted by servo motor with the help of Arduino UNO & gravity sensor.

Summary

We have designed and developed an advanced automatic sensing headlight system which can adapt according to the requirements. The design is done using CATIA V5 R20 software and accordingly calculations are done.

Acknowledgement

From bottom of my heart, We would like to thank our Prof. A. C. Shaikh for supporting and encouraging us. Your precious guidance is so valuable to us. Also we are very thankful to all are teaching, non- teaching staff and are friends who support us directly or indirectly.

Reference

- Adaptive Headlight System for Accident Prevention by Shreyas , Kirthanana Raghuraman¹, Padmavathy , S Arun Prasad, G.Devaradjane.
- A Review Paper On Intelligent Headlight System by Prof. G.S. Dhupal, Abhay N. Shinde, Abhijeet R. Tad, Akshay A. Andhale, Prashant K. Pawar.
- Design of Adaptive Headlights for Automobiles by Priyanka Dubal, Mr. Nanaware J.D.
- Adaptive Headlight System Vijay Mandal, Vellington Roy, Deepak Chandra, Shubham Yadu, Jitendra Yadav.
- SMART ADAPTIVE VEHICLE LIGHTING SYSTEM by Ch Prithviraj, K. Archana Bhangre.