

Review of Electric Vehicles, Batteries and Charging Station Models

Prashant Kale, Pratibha Chavan, Sushant Mudhe

¹ Department of E&TC Engineering, Trinity College of Engineering and Research, Pisoli, Pune
411048, Maharashtra, India

e-mail: kalepppppp@gmail.com; cpratibhapramod@gmail.com

Abstract

Presently all world is facing global warming issue and Electric vehicles are an important opportunity for reducing emissions gases like NOX, THC, CO2 etc. Electric vehicles not only reduce the dependency on basic fuel but also reduce the impact of ozone depleting substances and indorse large scale renewable deployment. The paper provides an overview of the studies of Electric Vehicle, Hybrid Electric Vehicle, Plug-in-Hybrid Electric Vehicle and Battery Electric Vehicle. Additionally, review of basic components used in electric vehicle, types of batteries used in electric vehicle and charging model used for batteries of electric vehicle. The research on the crucial barriers and insufficient charging facilities are spoke for a developing country like India that makes the study unique. We conclude that taking into account, the special characteristics of electric vehicles are so important in their mobility.

Keywords: Electric Vehicle Charging station (EVCS), Wireless Electric Vehicle Charging Stations (WEVCS) Technology

I Introduction

With the rapid increase in the Indian Automobile market, Electric Vehicles (EVs) are turning into a promising channel towards improving air quality, energy security and economic opportunity. The government of India recognizes the urgency to look at supportable mobility solutions to reduce dependency on imported energy sources, reduced gas emissions and diminish adverse impacts of transportation including global warming [1] [2]. The carbon dioxide emission can be reduced by taking precautionary measures to reduce the terrible climate change that threatens the species of this planet. Major endeavours have been taken for minimal use of basic fuels for power generation, transport propulsion, reduction of energy consumption. EVs could be the alternative to decrease the carbon dioxide gas emission [3] [4].

The electric vehicle industry in India is a growing industry. The central and state governments have launched schemes and incentives to promote electric mobility in the country and some regulations and standards are also in place. While the country stands to benefit in a large way by switching its transport from IC engines to electric motor-powered, there are challenges like lack of charging infrastructure, high initial cost and lack of electricity produced from renewable energy.

The objective of this research is

- Research on different types of Electric/Hybrid Vehicles and its working principles.
- Research on Electric Car Components and Functions.
- Research on Electric Car Batteries.
- Research on Electric Vehicle Charging Station (EVCS).
- Research on Wireless Electric Vehicle Charging Stations (WEVCS) Technology

II Types of Electric Cars and Working Principles

Types of Electric Cars

Different types of electric cars changed and are developed continuously giving users and potential users' choices. Today the world is progressively familiar with the terms BEV, HEV, PHEV and FCEV. We will briefly discuss the types and working principles of electric cars or vehicles marketed in the World and India today. An electric car is a vehicle that is fully or partially propelled by electric motors, using energy stored in rechargeable batteries [5]. The first practical electric cars were produced in the 1880s. Electric cars were popular in the late 19th century and early 20th century. Innovation and advanced development in internal combustion

engines (ICE) and mass production of cheaper gasoline vehicles has led to a decline in the use of electric vehicles [6].

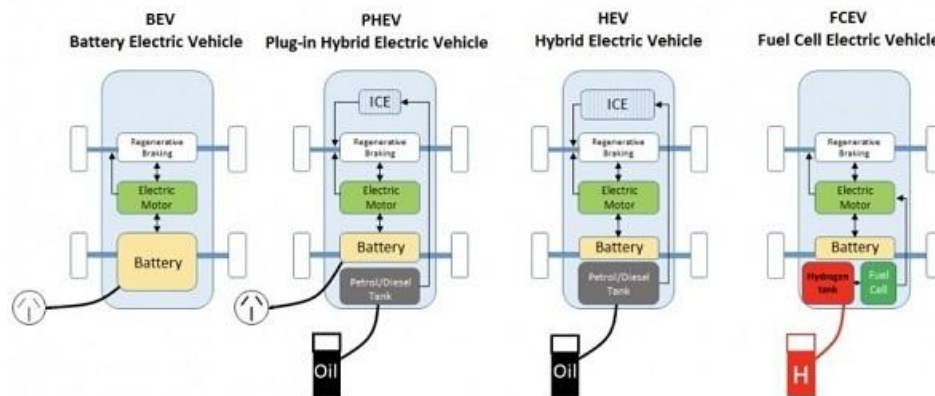

Fig1 System architecture for electric cars

The development of energy storage technology, especially battery technology, makes electric cars become more popular again at this time.

Working of electric vehicle

- Controller takes and regulates electrical energy from batteries and inverters
- With the controller set, the inverter then sends a certain amount of electrical energy to the motor (according to the depth of pressure on the pedal)
- Electric motor converts electrical energy into mechanical energy (rotation)
- Rotation of the motor rotor rotates the transmission so the wheels turn and then the car moves.

Types of Electric Cars

There are 4 (four) types of electric cars, with the following outline:

- Battery Electric Vehicle (BEV)
- Hybrid
 - Hybrid Electric Vehicle (HEV)
 - Plug-in Hybrid Electric Vehicle (PHEV)
- Fuel Cell Electric Vehicle (FCEV)

In brief, the system architecture of the four types of electric cars above can be seen in the figure 1

A) Battery Electric Vehicle (BEV)

A Battery Electric Vehicle (BEV), also called All-Electric Vehicle (AEV), runs entirely on a battery and electric drive train. These types of electric cars do not have an ICE. Electricity is stored in a large battery pack that is charged by plugging into the electricity grid. The battery pack, in turn, provides power to one or more electric motors to run the electric car [7].

Architecture and Main Components of

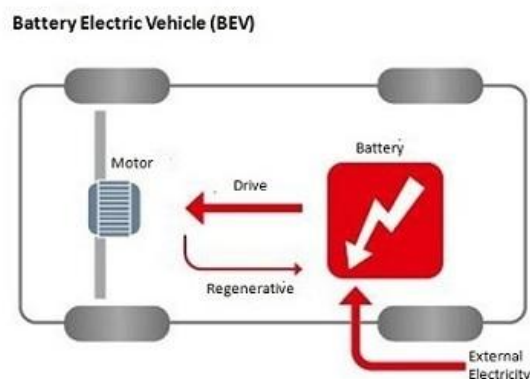

Components of BEV

- Electric motor
- Inverter
- Battery
- Control Module
- Drive train

Working of BEV

- Power is converted from the DC battery to AC for the electric motor
- The accelerator pedal sends a signal to the controller which adjusts the vehicle's speed by changing the frequency of the AC power from the inverter to the motor
- The motor connects and turns the wheels through a cog
- When the brakes are pressed or the electric car is decelerating, the motor becomes an alternator and produces power, which is sent back to the battery

Examples of BEV

Volkswagen e-Golf, Tesla Model 3, BMW i3, Chevy Bolt, Chevy Spark, Nissan LEAF, Ford Focus Electric, Hyundai Ioniq, Karma Revera, Kia Soul, Mitsubishi i-MiEV, Tesla X, Toyota R

B)Hybrid Electric Vehicle (HEV)

This type of hybrid cars is often called as standard hybrid or parallel hybrid. HEV has both an ICE and an electric motor. In this types of electric cars, internal combustion engine gets energy from fuel (gasoline and others type of fuels), while the motor gets electricity from batteries. The gasoline engine and electric motor simultaneously rotate the transmission, which drives the wheels.

The difference between HEV compared to BEV and PHEV is where the batteries in HEV can only charge by the ICE, the motion of the wheels or a combination of both. There is no charging port, so that the battery cannot be recharged from outside of the system, for example from the electricity grid.

Architecture and Main Components of HEV [8]

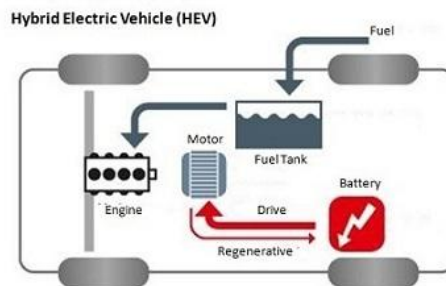

Components of HEV :-

- Engine
- Electric motor
- Battery pack with controller & inverter
- Fuel tank
- Control module

Working of HEV :-

- Has a fuel tank that supplies gas to the engine like a regular car
- It also has a set of batteries that run an electric motor
- Both the engine and electric motor can turn the transmission at the same time
-

Examples of HEV :-

Honda Civic Hybrid, Toyota Prius Hybrid, Honda Civic Hybrid, Toyota Camry Hybrid.

C)Plug-in Hybrid Electric Vehicle (PHEV)

PHEV is a type of hybrid vehicle that both an ICE and a motor, often called as series hybrid. This types of electric cars offers a choice of fuels. This type of electric cars is powered by a conventional fuel (such as gasoline) or an alternative fuel (such bio-diesel) and by a rechargeable battery pack. The battery can be charged up with electricity by plugging into an electrical outlet or electric vehicle charging station (EVCS).

PHEV typically can run in at least two modes:

- All-electric Mode, in which the motor and battery provide all the car's energy
- Hybrid Mode, in which both electricity and gasoline are employed.

Some PHEVs can travel more than 70 miles on electricity alone.

Architecture and Main Components of PHEV

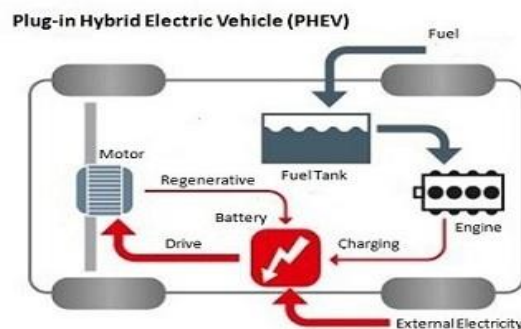

Components of PHEV

- Electric motor
- Engine
- Inverter
- Battery
- Fuel tank
- Control module
- Battery Charger (if onboard model)

Working of PHEV

PHEVs typically start up in all-electric mode and operate on electricity until their battery pack is exhausted. Once the battery is empty, the engine takes over and the vehicle operates as a conventional, non-plug-in hybrid. In addition to plugging into an outside electric power source, PHEV batteries can be charged by an internal combustion engine or regenerative braking. During braking, the electric motor acts as a generator, using the energy to charge the battery. The electric motor supplements the engine's power; as a result, smaller engines can be used, increasing the car's fuel efficiency without compromising performance [9].

Examples of PHEV

Porsche Cayenne S E-Hybrid , Chevy Volt, Chrysler Pacifica, Ford C-Max Energi, Ford Fusion Energi, Mercedes C350e, Mercedes S550e, Mercedes GLE550e, Mini Cooper SE Countryman, Audi A3 E-Tron, BMW 330e, BMW i8, BMW X5 xdrive40e, Fiat 500e, Hyundai Sonata, Kia Optima, Porsche Panamera S E-hybrid, Volvo XC90 T8.

D)Fuel Cell Electric Vehicle (FCEV)

Fuel Cell Electric Vehicles (FCEVs), also known as fuel cell vehicles (FCVs) or Zero Emission Vehicle, are types of electric cars that employ 'fuel cell technology' to generate the electricity required to run the vehicle. In this type of vehicles, the chemical energy of the fuel is converted directly into electric energy [10].

Architecture and Main Components of FCEV :-

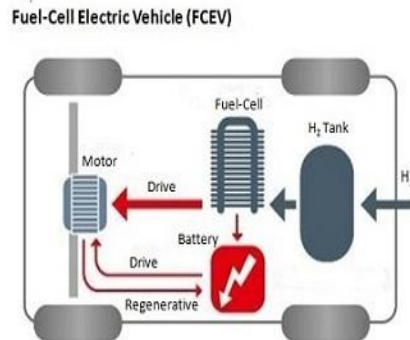

Components of FCEV:-

- Electric motor
- Fuel-cell stack
- Hydrogen storage tank
- Battery with converter and controller

Working of FCEV

The working principle of a 'fuel cell' electric car is different compared to that of a 'plug-in' electric car. These types of electric cars are because the FCEV generates the electricity required to run this vehicle on the vehicle itself.

Examples of FCEV :-

Toyota Mirai, Hyundai Tucson FCEV, Riversimple Rasa, Honda Clarity Fuel Cell, Hyundai Nexa.
Electric Car Components and Functions.

III) Electric Car/ Vehicle Components

A) Electric Car Components

Electric car or vehicle component and function depend on the car type. There are at least four types of electric cars. This article will discuss various common main electric car components or parts or elements and their function such as traction batteries, inverters (DC-DC converters), traction motors, on-board chargers and controllers. The different types of electric car components determine how the car works. Electric cars (vehicles) components and functions can be explained by means of picture below.

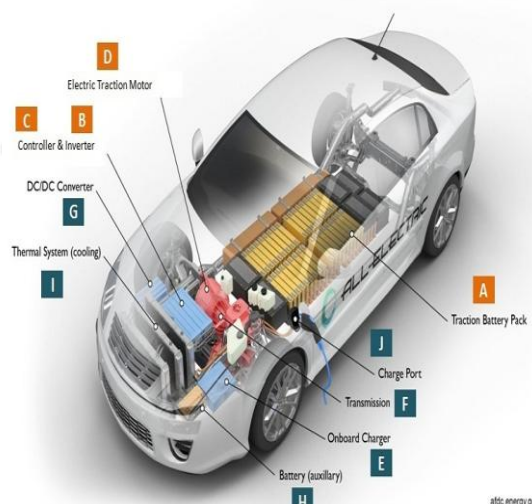

B) Electric Vehicle Components

Basic Main Components of Electrical Vehicle

The basic main elements of electric cars installed in almost all types of electric cars are as follows:

Traction Battery Pack (A)



The function of the battery in an electric car is as an electrical energy storage system in the form of direct-current electricity (DC). If it gets a signal from the controller, the battery will flow DC electrical energy to the inverter to then be used to drive the motor. The type of battery used is a rechargeable battery that is arranged in such a way as to form what is called a traction battery pack.

There are various types of electric car batteries. The most widely used is the type of lithium-ion batteries.

Power Inverter (B)



The inverter functions to change the direct current (DC) on the battery into an alternating current (AC) and then this alternating current is used by an electric motor. In addition, the inverter on an electric car also has a function to change the AC current when regenerative braking to DC current and then used to recharge the battery. The type of inverter used in some electric car models is the bi-directional inverter category.

Controller (C)



The main function of the controller is as a regulator of electrical energy from batteries and inverters that will be distributed to electric motors. While the controller itself gets the main input from the car pedal. This pedal setting will determine the frequency variation or voltage variation that will enter the motor, and at the same time determine the car's speed. In brief, this unit manages the flow of electrical energy delivered by the traction battery, controlling the speed of the electric traction motor and the torque it produces. This component will determine how electric car work.

Electric Traction Motor (D)



Because the controller provides electrical power from the traction battery, the electric traction motors will work turning the transmission and wheels. Some hybrid electric cars use a type of generator-motor that performs the functions of force and regeneration. In general, the type of electric motor used is the BLDC (brushless DC) motor

Other Electric Car Components



Charger (E) is a battery charging device. Chargers get electricity from outside sources, such as the utility grid or solar power plants. AC electricity is converted into DC electricity and then stored in the battery. There are 2 types of electric car chargers:

- On-board charger: the charger is located and installed in the car
- Off-board charger: the charger is not located or not installed in the car.
-

Transmission (F): The transmission transfers mechanical power from the electric traction motor to drive the wheels.

DC/DC Converter (G): This one of electric car parts that to converts higher-voltage DC power from the traction battery pack to the lower-voltage DC power needed to run vehicle accessories and recharge the auxiliary battery.

Battery (H): In an electric drive vehicle, the auxiliary battery provides electricity to power vehicle accessories.

Thermal System – Cooling (I): This system maintains a proper operating temperature range of the engine, electric motor, power electronics, and other components.

Charge Port (J): The charge port allows the vehicle to connect to an external power supply in order to charge the traction battery pack.

IV) Electric Car Batteries

Electric car batteries are one of the most important components in a car system. In BEV cars, electrical energy stored in the battery is the only source of energy driving the car. There are no other sources. The types of electric car batteries are also depending on the car system. The most popular electric car battery used is lithium-ion. Batteries. The most suitable battery for hybrid electric cars is NiMH. We will explain at a glance about the different types of electric vehicle batteries and their characteristics.

Types of Electric Car Batteries

Electric car batteries are different from SLI batteries (starting, lighting and ignition). SLI batteries are batteries that are usually installed in gasoline or diesel cars. This type of electric cars battery is designed as an energy storage system, capable of delivering power for long and sustainable periods.

There are 5 types of electric vehicle batteries to be discussed in this article:

- Lithium-Ion (Li-On)
- Nickel-Metal Hybrid (NiMH)
- Lead Acid (SLA)
- Ultracapacitor

	Lithium Ion	Nickel-Metal	Lead-Acid	Ultracapacitors
Easy Access / Inexpensive	✓	✗	✓	✗
Energy Efficient	✓	✓	✓	✓
Temp. Performance	✓	✗	✗	✓
Weight	✓	✓	✓	✓
Life Cycle	✓	✗	✓	✗

The comparison of the first four types of electric car batteries can be seen as follows:

A) Lithium-Ion Battery (Li-On)



This type of electric vehicle battery is most widely applied is the Li-On battery. Its physical capacity and size on electric cars is much greater. this is normally denoted to as a traction battery pack.

Li-on batteries have a very high power to weight ratio. This type of electric car battery is high energy efficiency. Performance at high temperatures is also good. energy ratio per weight is a parameter that is very important for electric car batteries. The smaller the battery weight (same kWh capacity) means the car can travel further with a single charge [11].

This battery also has a low “self-discharge” level, so the battery is better than any other battery in maintaining its ability to hold its full charge.

Most parts of Li-on batteries can be recycled, making it the right choice for those interested in environmentally conscious electric cars. BEV cars and PHEVs use the most lithium batteries.

Li-on battery Types

- Lithium Iron Phosphate(LiFePO4) — LFP
- Lithium Nickel Cobalt Aluminium Oxide (LiNiCoAlO2) — NCA
- Lithium Nickel Manganese Cobalt Oxide (LiNiMnCoO2) — NMC
- Lithium Titan ate (Li2TiO3) — LTO
- Lithium Manganese Oxide (LiMn2O4) — LMO
- Lithium Cobalt Oxide(LiCoO2) — LCO

B) Hybrid Nickel-Metal (NiMH) Batteries



NiMH batteries are more widely used by hybrid-electric vehicles (HEV). This type of hybrid electric car battery does not get power from outside (can be recharged from an outside source of the car system). The recharging of hybrid electric car batteries depends on engine speed, wheels and regenerative braking.

NiMH batteries have a longer life cycle than lithium-ion batteries or SLA batteries. NiMH batteries are safe and tolerant of incorrect usage.

The biggest disadvantages of NiMH batteries include:

- The price is relatively more expensive
- High self-discharge rate
- Generate significant heat at high temperatures.

C) Lead-Acid (SLA) Batteries

SLA (lead-acid) batteries are the oldest rechargeable batteries. Compared to lithium and NiMH batteries, lead-acid batteries do lose capacity and are much heavier, but the price is relatively cheap and safe. There are large capacity SLA electric car batteries under development, but SLA batteries are now only used by commercial vehicles as a secondary storage system.

V) Electric Vehicle Charging Station

Electric Vehicle (EV) and EVCS Components

EVCS delivers electrical energy from the power source to the EV, and ensures that an appropriate, and safe, flow of electricity is supplied to the vehicle. EVCS is the main interface between user, vehicle, and utility

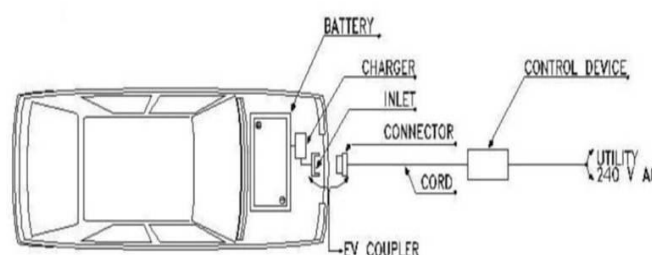

- Battery – Located on-board the vehicle and is the power (DC) storage component
- Charger – Converts power from AC to DC to charge the battery
- Inlet – Connection point on the vehicle
- Connector – Connection point from the charging station
- EV Coupler – Describes the connection between the 'Inlet' and 'Connector'
- Control Device – Provides power from the utility (AC)

EVCS Configurations

The following are typical configuration options for EVCS:

- Wall-mounted or free-standing

- Single charging head or multi-head
- Commercial or residential grade
- Indoor or outdoor instalment
-

Charging Station Types

Charging stations fall into four basic categories:

1. Residential charging stations
2. Commercial charging station (charging while parked, including public charging stations)
3. Fast charging at public EVCS >40 kW, delivering over 60 miles (100 km) of range in 10–30 minutes.

International or European Standards

Charging Mode

The International Electrotechnical Commission defines charging in modes (IEC-61851-1). Charging mode in EVCS:

- Mode 1 – slow charging from a regular electrical socket (single- or three-phase)
- Mode 2 – slow charging from a regular socket but with some EV specific protection arrangement
- Mode 3 – slow or fast charging using a specific EV multi-pin socket with control and protection functions
- Mode 4 – fast charging using some special charger technology such as CHAdeMO (CHAdeMO is of a fast charging method for battery electric vehicles delivering up to 62.5 kW by 500 V, 125 A direct current via a special electrical connector. A revised CHAdeMO 2.0 specification allows for up to 400 kW by 1000 V, 400 A direct current)

There are three connection cases:

- Case A is any charger connected to the mains (the mains supply cable is usually attached to the charger) usually associated with modes 1 or 2.
- Case B is an on-board vehicle charger with a mains supply cable which can be detached from both the supply and the electric vehicles usually mode 3.
- Case C is a dedicated charging station with DC supply to the vehicle where the mains supply cable may be permanently attached to the charge-station such as in mode 4.

Wireless Electric Vehicle Charging Stations (WEVCS) Technology

A) Wireless Charging Technology

Wireless electric vehicle charging stations (WEVCS) technology is charging an electric car without involving cables that are directly related to the vehicles system. Wireless charging is done without a connector. The location of wireless charging is called a wireless electric vehicle charging station. There is no plug on WEVCS like charging in standard EVCS. Wireless electric charger technology for electric cars is a recent development for charging batteries. The basic principle of an electric car charging or wireless charger system is the same as the working principle of the transformer. One of the advantages of wireless charger is that charging an electric car (vehicle) becomes safer and more convenient for users.

Working: If the transformer has a primary and secondary side, then charging without WEVCS cable has a transmitter side and a receiver side. If the transformer has a primary (coil) winding and secondary winding, the wireless charging of an electric car also consists of a transmitter winding and receiver winding.

However, wireless charging of electric cars changes the parameters of alternating current (AC) from low frequency 50Hz to high frequency, where it does not occur in the transformer. High-frequency AC power is supplied to the transmitter coil, then the alternating magnetic field is formed. This field then induces the receiver winding so that a voltage appears on the receiver winding. This voltage is used to charge the vehicle battery.

The most important thing in wireless charging or wireless charging to remain efficient is to maintain the frequency of resonance between the transmitter and receiver. In order for the resonance frequency to be maintained, compensation networks are added on both sides.

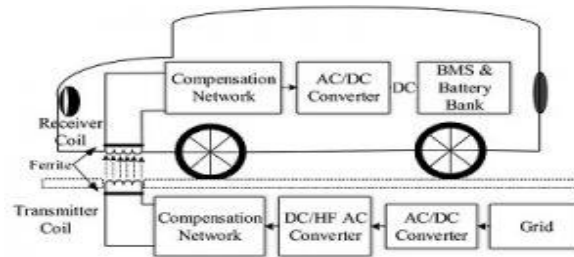

Wireless charging schematic for electric cars (WEVCS)

Static and Dynamic Wireless Charging

Based on the application, wireless electric vehicle charging stations cars can be divided into two categories,

- Static Wireless Charging
- Dynamic Wireless Charging

Static Wireless Charging



B) Static Wireless Charging Station (SWCS)

This wireless charging is also called a static wireless charging station (SWCS). As the name suggests, the car battery is charged when stationary (stops). We can park the vehicle in a parking lot that is combined with a wireless charging station. The transmitter is installed underground while the receiver is mounted under the vehicle. Charging is done by aligning the transmitter with the receiver and then silenced so that the charging or charging process takes place.

The duration of wireless charging depends on:

- Large AC power supply
- Distance between transmitter and receiver

Wireless charging of this SWCS electric car is best built in an area where the car is parked for a certain time interval.

Dynamic Wireless Charging System

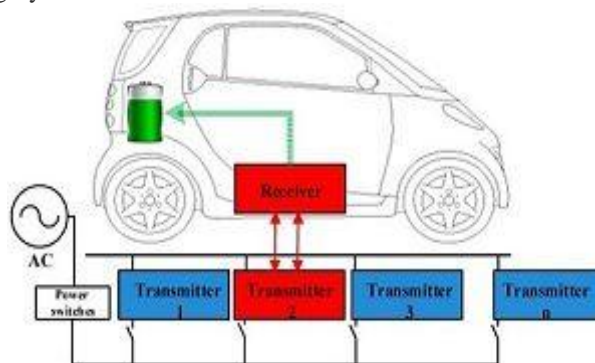

C) Dynamic Wireless Charging Station (DWCS)

Wireless charging is also called dynamic wireless charging station (DWCS). wireless charging or wireless charging can be done while the car is running. Power is transferred through the air from the stationary transmitter to the receiver winding of the moving vehicle. Wireless charging technology allows car mileage to be further away. Because, the battery is charged continuously during the trip. This reduces the need for a large car battery capacity so as to reduce the weight of the car. Reducing the load will further distance the mileage.

Types of Wireless Charging Electric Cars

Based on its operations, wireless electric vehicle charging stations (WEVCS) can be classified into four types

- Wireless Charging Capacitive (CWCS)
- Wireless Charging Permanent Magnetic Gear (PMWC)
- Inductive Wireless Charging (IWC)

D) Capacitive Wireless Charging

Charging wireless or wireless charging electric car type CWCS is done by using a displacement current due to variations in the electric field. Instead of magnets or winding as transmitters and receivers, coupling capacitors are used here as wireless power transmissions. The AC voltage is first supplied to the power factor correction circuit aimed at increasing efficiency, maintaining voltage levels and reducing transmission losses. Then it is supplied to the H-bridge for the generation of high frequency AC voltage. This high frequency AC applied to the transmission plate causes the development of an oscillating electric field then causes a displacement current on the receiving plate through electrostatic induction.

The receiver's AC voltage is converted to DC then charges the battery via a rectifier circuit and filter. The frequency, voltage, size of the clutch capacitor and the air gap between the transmitter and receiver affect the amount of energy transfer. The operating frequency is between 100 to 600 kHz.

Wireless Charging Permanent Magnet Gear

in this wi-fi charging generation for electric powered vehicles, every transmitter and receiver additionally includes armature windings and permanent magnets synchronized in the winding. The principle of operation of the transmitter facet is much like motor operation. when we apply AC modern to the transmitter, it will purpose mechanical torque at the transmitter magnet to reason its rotation. due to modifications in the transmitter's magnetic interplay, the PM subject causes torque at the PM receiver which leads to rotation in sync with the transmitter magnet.

Now the exchange within the receiver's everlasting magnetic discipline reasons the production of AC modern-day in the winding, that is, the receiver acts as a generator as an enter of mechanical power to the receiver's PM that's transformed to electric output at the receiver's winding. Rotating permanent magnetic snatch is known as magnetic gear. AC electricity generated on the receiver facet is fed to the battery after repairing and filtering via the electricity converter

Inductive Wireless Charging

The fundamental precept of wireless charging or wireless charging of electrical cars is Faraday's induction law. here, wireless transmission is achieved by means of inducing a magnetic field among the transmitter coil and the receiver. while the main AC supply is applied to the transmitter coil, it creates an AC magnetic subject that passes thru the transmitter coil and this magnetic area moves electrons in the receiver winding causing AC strength output. The AC output is repaired and filtered and then fills the automobile's power garage machine. the amount of switch on the electrical car charger depends on frequency, mutual inductance and the space between the transmitter and the receiver coil. The working frequency of wi-fi charging IWC electric cars is between 19 to 50 kHz.

Resonant Inductive Wireless Charging

This wireless electric automobile or automobile charger station is basically a resonator with a excessive pleasant component transmitting power at a far higher price. because it operates at resonance, despite weaker magnetic fields, we can transmit as much power as switch potential as at IWC. strength can be transferred remotely wi-fi. maximum energy transfer via the air happens whilst the winding of the transmitter and receiver is adjusted in order that the frequencies of the two resonant coils need to fit. So so as to get a terrific resonance frequency, a further collection-parallel combination repayment network is brought to the transmitter and receiver coils. the extra repayment network on this electric automobile charger need to adjust the growth in resonant frequency while additionally reducing additional losses. RIWC running frequency is between 10 to a hundred and fifty kHz.

Conclusion

The progress that the electrical automobile enterprise has seen in latest years is not most effective extraordinarily welcomed, but extraordinarily essential in light of the growing global greenhouse fuel stages. As verified within the economic, social, and environmental analysis sections of this web site, the advantages of electrical cars a ways surpass the charges. the most important impediment to the significant adoption of electric-powered transportation is cost associated, as gas and the motors that run on it are effectively available, handy, and less costly. As is proven in our timeline, we are hoping that over the path of the next decade technological improvements and policy changes will assist ease the transition from traditional gas-powered automobiles. additionally, the belief and fulfilment of this industry is predicated heavily on the worldwide populace, and it's miles our wish that via mass marketing and environmental schooling packages humans will experience incentivized and empowered to force an electric powered-powered car.

References :-

- [1] Modification of Cycle Life Model for Normal Aging Trajectory Prediction of Lithium-Ion Batteries at Different Temperatures and Discharge Current Rates by Xinyu Jia, Caiping Zhang, Leyi Wang, Weige Zhang and Linjing Zhang World Electr. Veh. J. 2022, 13(4), 59; <https://doi.org/10.3390/wevj13040059> (registering DOI) - 28 Mar 2022
- [2] The Capacity of Battery-Electric and Plug-in Hybrid Electric Vehicles to Mitigate CO2 Emissions: Macroeconomic Evidence from European Union Countries by Matheus Koengkan, José Alberto Fuinhas, Mônica Teixeira, Emad Kazemzadeh, Anna Auza, Fatemeh Dehdarand Fariba Osmani World Electr. Veh. J. 2022, 13(4), 58; <https://doi.org/10.3390/wevj13040058> - 24 Mar 2022
- [3] Performance Comparison of High-Speed Motors for Electric Vehicle by Kohei Aiso and Kan Akatsu World Electr. Veh. J. 2022, 13(4), 57; <https://doi.org/10.3390/wevj13040057> - 23 Mar 2022
- [4] Placing BEV Charging Infrastructure: Influencing Factors, Metrics, and Their Influence on Observed Charger Utilization by Lennart Adenaw and Sebastian Krapf World Electr. Veh. J. 2022, 13(4), 56; <https://doi.org/10.3390/wevj13040056> - 22 Mar 2022
- [5] Adaptive Pre-Aim Control of Driverless Vehicle Path Tracking Based on a SSA-BP Neural Network by Yinggang Huang, Wenguang Luo and Hongli Lan World Electr. Veh. J. 2022, 13(4), 55; <https://doi.org/10.3390/wevj13040055> - 22 Mar 2022
- [6] A Model Predictive Control Method for Vehicle Drifting Motions with Measurable Errors by Dongxin Xu, Yueqiang Han, Chang Ge, Longtao Qu, Rui Zhang and Guoye Wang World Electr. Veh. J. 2022, 13(3), 54; <https://doi.org/10.3390/wevj13030054> - 18 Mar 2022
- [7] A.M. Andwari, A. Pesiridis, S. Rajoo, R. Martinez-Botas, V. Esfahanian A review of battery electric vehicle technology and readiness levels Renew. Sustain. Energy Rev., 78 (2017), pp. 414-430
- [8] N.C. Wang, Y. Qin Research on state of charge estimation of batteries used in electric vehicle Proceedings of the Asia-Pac Power Energy Eng Conference (2011), pp. 1-4
- [9] "Electric Cars @Project Draw down #Climate Solutions". Project Drawdown. 6 February 2020. Archived from the original on 27 November 2020. Retrieved 20 November 2020.
- [10] Mok, Brian. "Types of Batteries Used for Electric Vehicles". large.stanford.edu. Archived from the original on 19 December 2017. Retrieved 30 November 2017
- [11] "EV charging station guidelines to support dual platforms". Team-BHP. 18 December 2018. Retrieved 26 May 2020.