

BIOMETRIC BASED SMART RAILWAY RESERVATION SYSTEM WITH SMS FACILITY

P. Naren Suchendra Das¹, G. Bhargavi²,

G. Ravindranath Kumar³

¹Pursuing M.Tech (ES), ² Assistant Professor, ³ professor

*Visvesvaraya College of Engineering and Technology, Patelguda, Ibrahimpatnam, Ranga Reddy Dist.
Telangana, (India)*

ABSTRACT

In the New era of technology all system has got to be updated, Asian nation/Bharat/Asian country/Asian nation\n Railway is the 2nd largest Rail Network in India it's the backbone of public and product transport in India. Bulk of long distance traffic is carried by the Indian Railway. RFID system at many transport system therefore we tend to assume to implement bioscience in our analysis then determined to use fingerprint module conjointly for the add-on for user flexibility victimization GSM module for Communication purpose of causation and receiving message. In our Project Research we tend to square measure attempting to reduce railway Reservation Fraud and provides additional facility to person and improve society. Also alter the Reservation System in that we'll take fingerprint of the one that goes for reservation/ticket booking and facilitate lots humanitarian by this innovative technology. Standalone module which contains Finger Print Module verify the person's identity.

KEY WORDS: LPC2148, FINGER PRINT MODULE, GSM.

I. INTRODUCTION

This Project consist finger print module, GSM module, LPC2148 micro controller earlier price {ticket} issue by mistreatment manual it is not that abundant secure and a few different persons additionally might travel thereupon ticket, if passenger lose the price ticket he can't travel. By using this project we tend to will avoid those issues, by using GSM module licensed person get the message if traveller lose the price ticket he will travel by showing that message , by using finger print module solely licensed person will travel. This project helps to Indian Railways also they will simply establish un-reserved persons simply.

II. LITERATURE REVIEW

This Project consist finger print module, GSM module, LPC2148 micro controller earlier price {ticket} issue by mistreatment manual it is not that abundant secure and a few different persons additionally might travel

thereupon ticket, if passenger lose the price ticket he can't travel. By using this project we tend to will avoid those issues, by using GSM module licensed person get the message if traveller lose the price ticket he will travel by showing that message , by using finger print module solely licensed person will travel. This project helps to Indian Railways also they will simply establish un-reserved persons simply.

III.HARDWAREDESIGN

Block Diagram

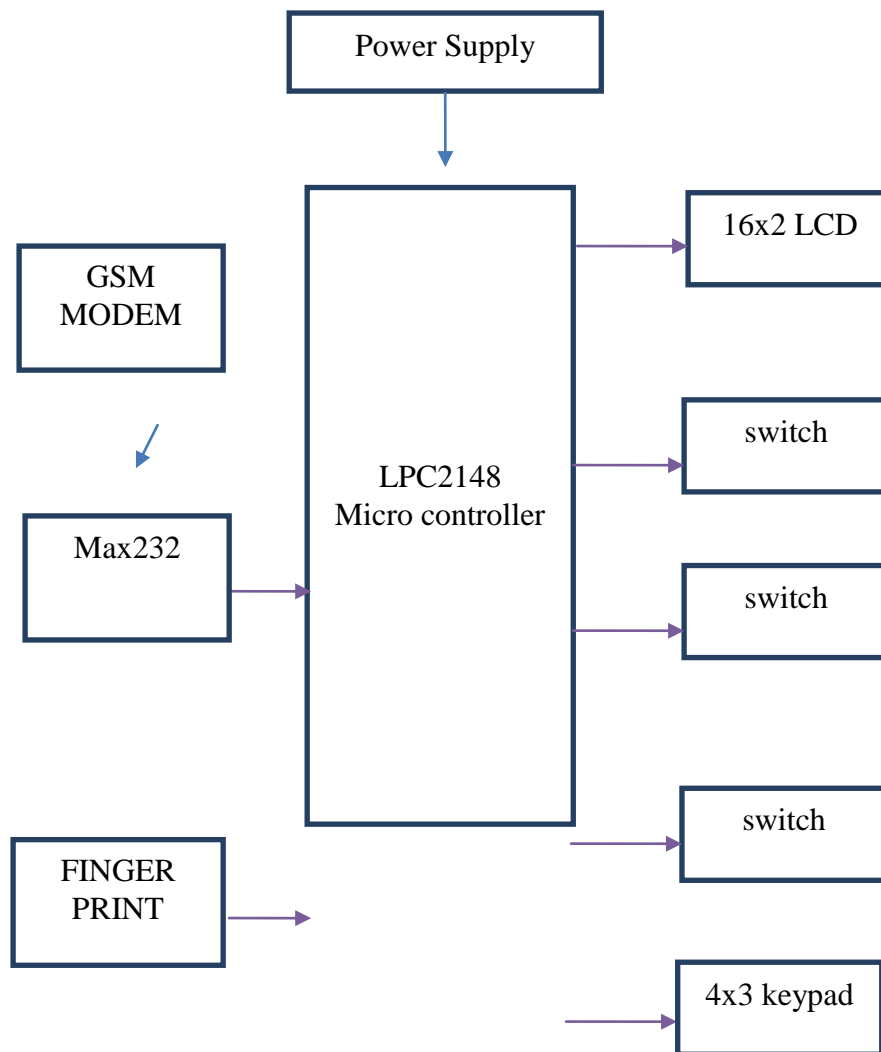

FIG1: block diagram

LPC2148

4.2 Key Pad

A keypad is a set of buttons organized in numbers and letters, digits and other symbols however not a complete set of alphabetical letters. If it mostly contains numbers then it will conjointly be known as a numeric data input device. Keypad area unit victimization typewriting of security purpose area unit found on several alphabetic keyboards and on alternative devices such as calculators. It's given that an data input device, sometimes half of a typical keypad, consisting of a separate grid of numerical and function keys organized for economical information entry.



Fig 5 : 4X3 keypad

4.3 Fingerprint

The ARA-EM01 is high performance fingerprint module developed by Aratek statistics Technology Co, Ltd .it has several options : simple reconstitute, powerful functions, compatible with PC, and multiple-functions in one module: Fingerprint enrolment, image method, characters acquisition, fingerprint template creation, fingerprint template storage, fingerprint compare (1: one, 1: N), fingerprint delete. This module will work with totally different devices supported UAWRT like laptop, SCM so on. solely simple circuits and fingerprint module will enhance your product into fingerprint authentication power. it's wide employed by natural philosophy business, data security, access management, identity authentication and alternative security business



Fig 4: finger print module

V. SOFTWAREDESIGN

In this proposed a dgetas we used LPC2148wewantto use following software equipment to program for it.

1. Keil4Vision
2. Flash Magic

The Keil4 Vision is an IDE for Embedded dc language. In this IDE, we want to import the utilities and

libraries according to the controller we're the use of. This IDE is very less difficult and in user friendly way to apply. It consist so fall he C/C++ compilers, assemblers, and debuggers in it. It simplifies the manner of embedded simulation and trying out in conjunction with Hex file technology. The flash magic is a programming utility. The C/C++ software written in IDE may be processed into hex document if in .hex layout. By using hex file we dump the code in to micro controller and perform the task with respective application.

VI. WORKING DISCRPTION

The most objective of the project is store the knowledge and collectively transmit the data through native house network technology. In this project the micro controller plays a big role to perform the desired task. The micro controller we used in this project is ARM seven LPC2148 that has several inherent choices like ADC, SPI, I2C, PWM, and RTC. The finger print sensors which space unit interfacing directly with micro controller and that we tend to write down the code in such manner to talk with the micro controller and perform the actual task. The GSM module is interfaced with micro controller which is used to send the message to specific mobile selection.

VII. WORKINGPROJECT

The project is designing of lpc2148 micro controller its operational with the user finger print, in this project an finger print module we tend to area unit victimization to guard to rider price ticket and person identification of licensed person for security par purpose. And this project have one GSM module to send the conformation message. When person book a price ticket he/she should offer their finger print then solely booking is done and he get authentication message otherwise he don't get. This process is a lot of secure and reliable. If persona lose the price ticket they lose their reservation earlier days by victimization this project overcome that drawback if person ticket lose he have message. And this proposed system a lot of secure solely licensed person will have that message if anyone have duplicate message by victimization biometric system they will realize World Health Organization licensed person for that reservation is. This system may facilitate to Indian railways too.

VIII . RESULTS

Here the results are shown our project "simplified secure wireless railway for public transport" whenever fingerprint notice not un-matched finger he is not approved person they will simply notice the person. Here GSM connecting in lpc2148 microcontroller it is accustomed send the message to particular person.

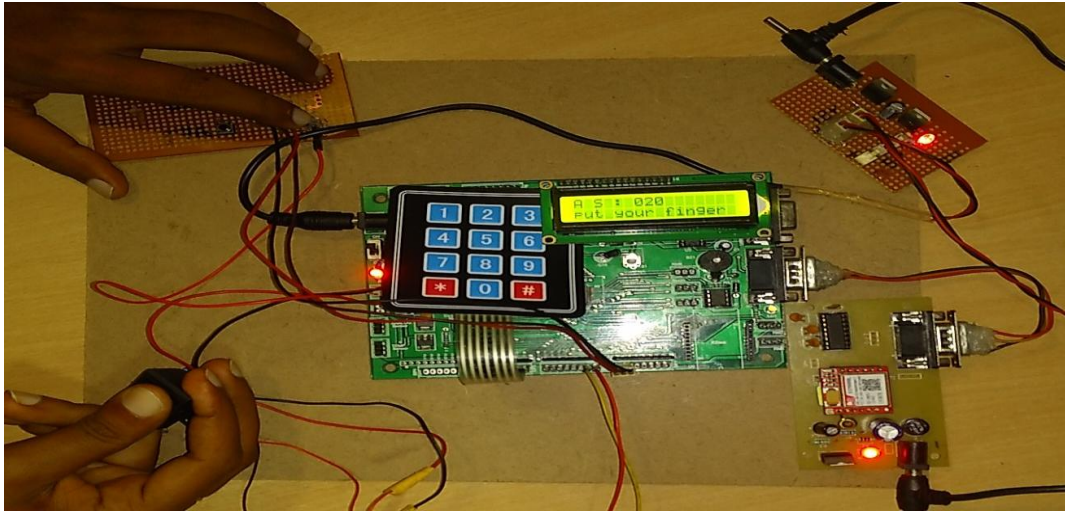



V111. CONCLUSION

In these project GSM technology using for message causing has with success designed and testing. In all hardware components its developed by desegregation options square measure used. presence of every parts reasoned placed rigorously checkout in outputs. its as highly advanced lpc2148 microcontroller with facilitate of technology the project has been with success.

REFERENCES

- [1] Mary Lourde R and Dushyant Khosla, || Fingerprint Identification in Biometric Security Systems|| ,International Journal of Computer and Electrical Engineering, Vol. 2, No. 5, October, 2010
- [2] D. Vinod kumar, Prof.M R K Murthy, — Fingerprint Based ATM Security by using ARM7|| , IOSR Journal of Electronics and Communication Engineering (IOSRJECE) ISSN : 2278-2834.
- [3] Hugh Wimberly, Lorie M. Liebrock, —Using Fingerprint Authentication to Reduce SystemSecurity: An Empirical Study|| , 2011 IEEE Symposium on Security and Privacy.
- [4] Kumar Chaturvedula, — RFID Based Embedded System for Vehicle Tracking and Prevention of Road Accidents|| , International Journal of Engineering Research & Technology (IJERT), Vol. 1 Issue 6, August – 2012.
- [5] Gangi.Raghu Ram, N.Rajesh Babu, — Tracking objects using RFID and Wireless Sensor Networks|| ijusat| International Journal Of Engineering science & Advanced technology Volume-2, Issue-3.
- [6] Vishy Karri1, Daniel J.S. Lim2, —Method and Device to Communicate via SMS After a Security Intrusion|| , 1st International Conference on Sensing Technology November 21-23, 2005 Palmerston North, New Zealand.
- [7] Pramila D. Kamble, Dr.Bharti, W. Gawali, — Fingerprint Verification of ATM Security System by Using Biometric and Hybridization|| , International Journal of Scientific and Research Publications, Volume 2, Issue 11, November 2012.
- [8] Art Conklin1, Glenn Dietrich2, Diane Walz3, —Password Based Authentication: A System Perspective|| , Proceedings of the 37th Hawaii International Conference on System Sciences –2004.

AUTHOR DETAILS

	<p>P.NAREN SUCHENDRA DAS Pursuing M.Tech (ES) from, visvesvaraya college of engineering and technology, Patelguda, Ibrahimpatnam, Rangareddy dist., Telangana, (India).</p>
	<p>G.BHARGAVI, working as assistant professor, from visvesvaraya college of engineering and technology, patelguda, Ibrahimpatnam, Rangareddy dist., Telangana, (India).</p>
	<p>G.RAVINDRANATH KUMAR (HOD) working as Professor from Visvesvaraya College Of Engineering And Technology, Patelguda, Ibrahimpatnam, RangaReddy dist., Telangana, (India).</p>