

SPEED CONTROL OF DC MOTOR USING ANDROID

Syed Aribuddin¹, Pushpa Gothwal², Abhishek Pandey³

^{1,2,3} Dept. of ECE (ASET), Amity University Rajasthan, (India)

ABSTRACT

This paper presents is to design the prototype model for controlling the devices at home, in industries, medical and robotics using mobile phone based on the android platform. The project objective is to control the speed of DC motor using available android application called as Bluetooth SPP pro and it can also rotate motor in clockwise and anticlockwise direction. It is designed using an android app (Bluetooth SPP pro), basic microcontroller (AT89s52), Bluetooth module (HC-05) and LCD (HD44780). The android app is the core part of the project, which is used to send command to the Bluetooth module and further send to the microcontroller to control the speed of DC motor via driver IC (L293D) and it will also display the working status of the motor on the LCD. This project is practical in the economic view and hence gives a reliable, durable, accurate and most efficient way of a DC motor control

Keywords: Microcontroller (AT89S52), Bluetooth Module (HC-05), Bluetooth SPP Pro (App)

I. INTRODUCTION

The world is full of tech geeks, every person in this universe have become so advanced that their life is incomplete without electronic gadgets. Everyone wants to make their life simpler and comfortable. In regard to this, speed control using android app can be a boon to human beings as human could control their equipment and their speed with the help of an android application not only android but this could be used for IOS, windows OS etc. For many of us, our mobile technology has been sewn into the fabric of our lives and is simply part of how we operate now. Because of mobile technology, knowledge is available to more people throughout the world than ever before.

What could be this world without newer technology such as smart phones, remote control and other electronic gadgets, our life would have been miserable. everything would have been done manually or with the help of switches located far away, let us suppose a huge generator in any industry or any machine at our home is running and to turn it off we have to ask any assistant to do that but why not any application or any remote could do this simple task by sitting at our place, so by highlighting this simple example in our mind we can use any android app designed by anyone or our self for controlling any equipment or devices and their speed very easily and effectively. After observing the true need of android apps in modern trend in the field of automation is to use wireless supervision and feedback processes. This fact became the reason behind the decision to design and build my undergraduate project, Speed control of DC motor using Android app.

II. BLOCK DIAGRAM

The block diagram consists of the whole setup of my project in well-organized manner. Starting with the power supply it consists of a 12 V step down transformer, as my whole project has the requirement of DC supply so this AC voltage must be converted into DC with the help of a bridge rectifier after bridge rectifier, 12 V DC

supply is received now this 12 V is converted to 5 V DC with the help of Voltage regulator. This voltage regulator is supplying 5 V to Microcontroller, Driver IC, Bluetooth module which are important equipment's of my project. Motor driver is used to drive the motor in different direction but the DC motor used in my project is of 12 V rating so the driver must be supplied to 12 V DC as shown in the diagram for getting the required results. LCD, Bluetooth module (HC -05) and Driver IC have been interfaced with the Microcontroller (AT89S52). Finally the Android app is used to control the whole project by giving command signal to the interfaced Bluetooth module

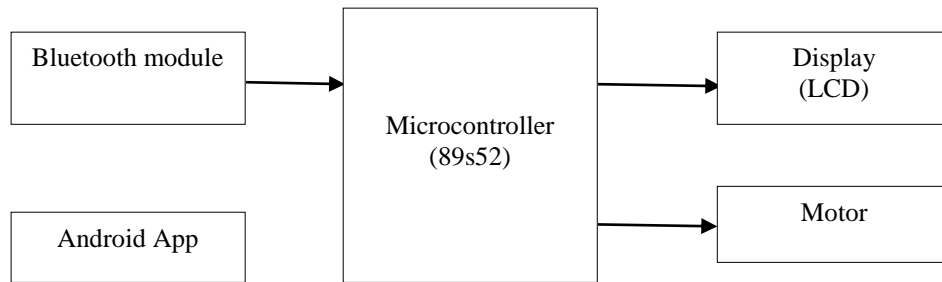

Fig. 1 Block Diagram

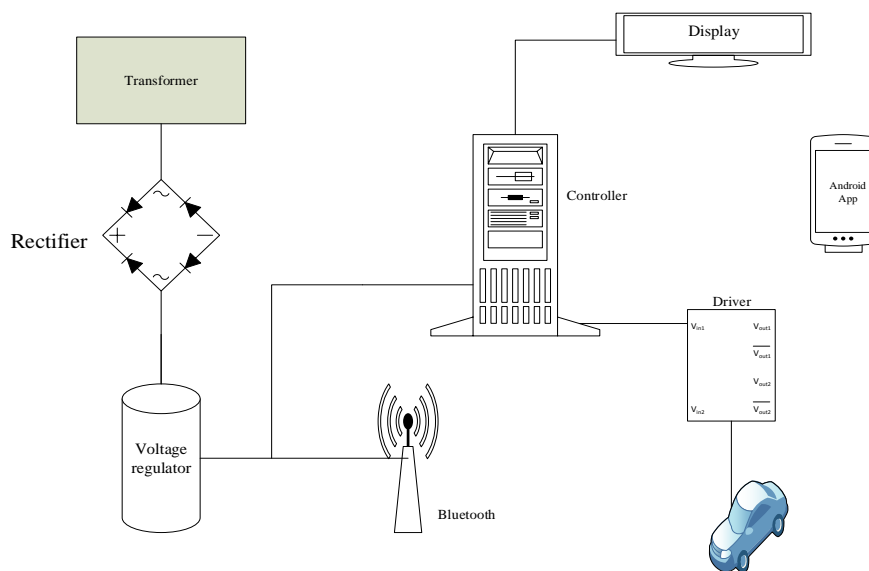

Fig.2 Instrument Setup



Fig.3 Interface of the Android App .

III. SCHEMATIC DIAGRAM

The complete schematic diagram as shown in figure 4. It explains each schematic components and its connection very clearly with the respective ports and pins of the microcontroller. At the centre there is main component i.e. the brain of the project, Microcontroller AT89s52 which connects all other components directly. LCD consists of 16 pin. In this schematic diagram it is depicted only 11 pins which are being connected to the microcontroller rest pins requires ground and power supply of 5 V. RS, RW, EN pins of LCD are connected to P1.0, P1.1, P1.2 pins of the microcontroller respectively. Data pins of LCD DB0 to DB7 are connected to Port 2 of the microcontroller as shown in the circuit diagram they are used to transmit the data.

Driver IC (L293D) has 16 pins. Few pins are shown in the circuit diagram. As pin 2 and 7 of driver IC are connected to P1.3 and P1.4 pin of microcontroller they are input pins. 8th pin of IC requires 12 V supply for driving the motor and 16th pin of IC is connected to 5 V. BTM in the circuit diagram is Bluetooth module which could be said as the heart of my project as it is main working components which receives and transmits information to the microcontroller as shown in the diagram, RX pin of BTM must be connected to TX pin of microcontroller and vice-versa. In this circuit diagram crystals pins XTAL1 and XTAL 2 are also shown with their proper connection to the crystal and capacitors this is for matching the clock frequency and for complete synchronization of functions inside microcontroller. 9th pin of the microcontroller is the reset pin which requires a reset button along with capacitor of 10uf and resistor of 10 k ohm. The 20th pin of the microcontroller is the ground pin, which must be supplied to the ground. 40th pin of the microcontroller must be supplied to 5V supplies which is required for its working. 31th pin is the enable pin which must be set high for receiving and transmitting command into the microcontroller.

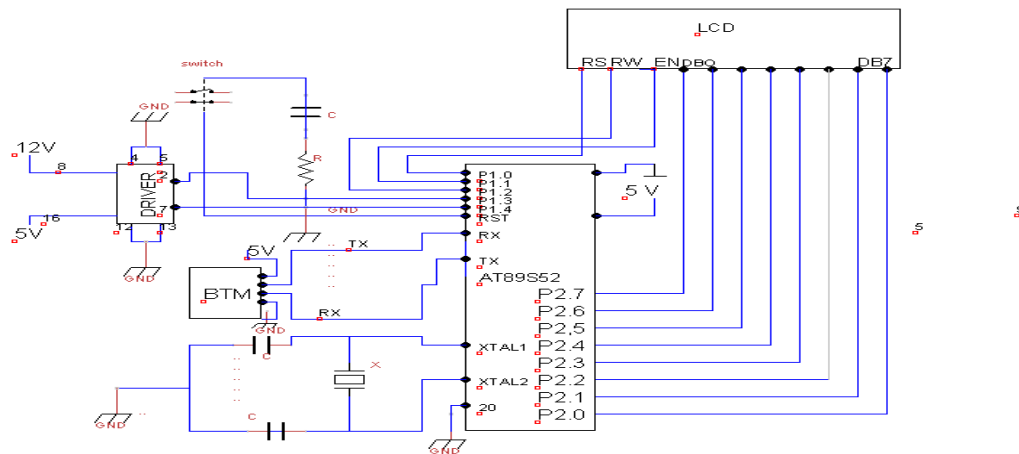

Fig. 4 Schematic Diagram of the Complete System

IV. CONCLUSION

This paper presents the prototype model of controlling the home appliances using mobile app. We control a DC motor with an android application named Bluetooth SPP Pro. We are able to increase motor's speed in both clockwise and anticlockwise direction from 25 %, 50%, 75%, 100% and also able to decrease motor's speed in both the directions clockwise and anticlockwise from 100%, 75%, 50%, 100%. It could be boon for making everyone's life better and content.

V. ACKNOWLEDGEMENT

It takes immense pleasure in presenting before you, my project, which is result of studied blend of both research and knowledge. I would like to express my sincere gratitude to my supervisor, Ms. Pushpa Gothwal, Assistant professor, Department of ECE, Amity University Rajasthan, for her constant support, encouragement and guidance. I am thankful for her cooperation and her valuable suggestions.

REFERENCES

- [1] Dinesh Suresh Bhadane, Monali D. Wani, Sanjeev. A. Shukla, Aniket R. Yeole, "A Review on Home Control Automation Using GSM and Bluetooth," International Journal of Advanced Research in Computer Science and Software Engineering, Vol.5(2) , Feb. 2015.
- [2] Ruta A. Bhave, Mitali S. Gogate, Ajay A. Maity, Priyanka D. Shivthare Department of Electronics and Telecommunication Engineering, Fr. Conceicao Rodrigues Institute of Technology. "Wireless Automation of an Electrical Drive using Bluetooth". International journal of engineering sciences & Research Technology. Vol 2(11), Nov, 2013
- [3] AT89S52 "Atmel microcontroller", available at <http://www.electroschematics.com/11111/at89s52-datasheet>.
- [4] Avoiding road accidents through "Bluetooth technology" available at contest.techbriefs.com/2011/entries/safety-and-security/1712