

# RETROFITTING OF RC SLAB BY USING ARAMID FIBRE WITH DIFFERENT PATTERN

Sagar S Wale<sup>1</sup>, Urmila S mane<sup>2</sup>, Jyoti R Bhandari<sup>3</sup>, Amol A Dhamke<sup>4</sup>,  
Makrand D Sagale<sup>5</sup>, Prof. D. R. Patil<sup>6</sup>

<sup>1,2,3,4,5,6</sup>Department of Civil Engineering , SIER Agashind Nashik

## ABSTRACT

*Aramid Fiber as an external reinforcement is used extensively to deal with the strength requirements related to flexure in structural systems. In the present work, the behavior and performance of rectangular reinforced concrete slab strengthened with externally bonded Aramid Fiber subjected to flexure is studied experimentally.*

*Rectangular RC slab externally bonded with Aramid Fiber. Each panel is subjected to equal static loading during the experiment. Total Nine RC slabs will be cast and tested for the study. In that nine panels will be designed for one way. three panels will be use as a control panel and six slab panels were strengthened using different configurations and different types of Aramid Fiber. The study is restricted to continuously wrapped Aramid Fiber wrapped with strip of Aramid Fiber.*

*The effect of different types and configuration of Aramid Fiber on first crack load, ultimate load carrying capacity and failure mode of the slab were investigated.*

**Keywords:** *Aramid Fiber , Flexural Strength , Strengthening.*

## I. INTRODUCTION

Strengthening of existing structures has become a major part of construction activity in our country. Many civil structures are no longer safe due to increased load specifications in the design codes. Such structure must be strengthened in order to maintain their serviceability. Strengthening refers to the reconstruction or renewal of any part of an existing building to provide better structural capacity like higher strength and ductility than the original building. The various strengthening techniques include steel plate bonding, polymer injection followed by concrete jacketing, use of advanced composite materials like aramid fiber reinforced polymer (AF), carbon fiber reinforced polymer (CF) and ferrocement etc. the choice of a particular strengthening method depends upon the type, nature and cause of distress to be repaired. Nowadays, strengthening using CF, AF etc. is gaining popularity due to their high strength-to-weight ratio and corresponding fatigue resistance.

In RC buildings, slabs are subjected to large forces during severe ground shaking and its behavior has a significance influence on the response of the structure. Hence slab is the crucial zone in a reinforced concrete moment resisting frame. The revisions of Indian code provisions have necessitated strengthening of several existing structure in country. The exposed joints in those structures such as frames of industrial buildings, water tanks, bridges and other structure can be strengthened by giving adequate lateral confinement using ferrocement or fiber reinforced polymer (FRP) composites.

A lot of work have been carried out world-wide to evaluate the performance of slab strengthened using various composites. The experimental programmers in the present investigation has been carried out to study the effect of various strengthening materials such as, AF,CF on the performance RC slab under static as well as cyclic loading. A significant improvement in the moment carrying capacity, energy absorption, etc. was observed for all the strengthened specimens.

## 1.1 Objective & scope

The maintenance, rehabilitation and upgrading of structural members, is perhaps one of the most crucial problems in civil engineering application. Moreover, a large number of structure constructed in the past using the older design code in different part of the world are structurally unsafe according to new design codes. Since replacement of such deficient elements of structures incurs a huge amount of public money and time, strengthening has become the acceptable way of improving their load carrying capacity and extending their service lives. Infrastructure decay caused by premature deterioration of building and structure has lead to the investigation of several processes for repairing or strengthening purpose. One of the Challenges in strengthening of concrete structure is selection of a strengthening method that will enhance the strength and serviceability of the structure while addressing limitation such as constructability, building operation and budget. Structural strengthening may be required due to many different situations.

- 1.1.1 Additional strength may be needed to allow for higher load to be placed on the structure. This is often required when the use of the structure changes and a higher load carrying capacity is needed. This can also occurs if additional mechanical equipment, filing systems, planters or other items are being added to a structure.
- 1.1.2 Strengthening may be needed to allow the structure to resist loads that were not anticipated in the original design. This may be encountered when structural strengthening is required for load resulting from wind and seismic forces or to improve resistance to blast loading.

## 1.2 Flexural Strengthening of Reinforced Concrete (RC) slab

Early efforts for understanding the response of plain concrete subjected to pure torsion revealed that the material fails in flexural rather than shear. Structural members curved in plan, members of a space frame, ultimate loaded slab, curved box girders in bridges, spandrel beams in buildings, and spiral stair-cases are typical examples of the structural elements subjected to Flexural moments cannot be neglected while designing such members. Structural members subjected to flexural are of different shapes such as one way, two way slab sections. These different configurations make the understanding of flexural in RC members a complex task.

In addition, torsion is usually associated with bending moments and shearing forces, and the interaction among these forces is important. Thus, the behavior of concrete elements in flexural is primarily governed by the tensile response of the material, particularly its tensile cracking characteristics. Spandrel beams, located at the perimeter of buildings, carry loads from slabs. This loading mechanism generates flexural forces in the slab. Reinforced concrete (RC) slab has been found to be deficient in flexural capacity and in need of strengthening. These deficiencies occur for several reasons, such as insufficient stirrups resulting from construction errors or inadequate design, reduction in the effective steel area due to corrosion, or increased demand due to a change in occupancy.

Similar to the flexure and shear strengthening, the aramid fiber is bonded to the flexural surface of the RC members for flexural strengthening. In the case of flexural, all sides of the member are subjected to diagonal tension and therefore the FRP sheets should be applied to all the faces of the member cross section. However, it is not always possible to provide external reinforcement for all the surfaces of the member cross section. In cases of inaccessible sides of the cross section, additional means of strengthening has to be provided to establish the adequate mechanism required to resist the torsion.

### 1.3 Introduction to Aramid fiber

Aramid fibers are organic fibers, made of aromatic polyamides in an extremely oriented form. First introduced in 1971, they are characterized by high toughness. Their Young modulus of elasticity and tensile strength are intermediate between glass and carbon fibers. Their compressive strength is typically around 1/8 of their tensile strength. Due to the anisotropy of the fiber structure, compression loads promote a localized yielding of the fibers resulting in fiber instability and formation of kinks. Aramid fibers may degrade after extensive exposure to sunlight, losing up to 50 % of their tensile strength. In addition, they may be sensitive to moisture. Their creep behavior is similar to that of glass fibers, even though their failure strength and fatigue behavior is higher than Aramid fibers. FRP composites based on Aramid fibers are usually denoted as AR. For strengthening purposes in Civil Engineering carbon fibers are the most suitable. Generally, all fibers are linear up to failure and have higher stress capacity than ordinary steel. The most important properties that differ between the fiber types are stiffness and tensile strength. Aramid fiber is a strong, heat-resistant fiber formed of polymers with repeating aromatic groups branching from a carbon backbone. In the polyamide fibers, at least 85% of the amide linkages are attached directly to two aromatic rings. Two types of Aramid materials are used in Meta Aramid paper which is used for making honeycomb core materials required for sandwich construction Para- Aramid fibers are made by the solution poly condensation of Di-amines and Di-acid halides. The oriented Para substituted aromatic units provide a rod like polymer. The rod like structure results in a high glass transition temperature and poor solubility. They are not spin able by conventional process and hence they are made by the dry- jet wet spinning of liquid crystalline polymer solutions.

Aramid Fiber is also known as Kevlar fiber. Aramid fiber is also high strength, tough and highly oriented organic fiber derived from polyamide incorporating into an aromatic ring structure. Kevlar is used in bullets resistance jacket. This fiber is quite abrasive and under repeated loading they can abrade against each other by weakening the sheets. Aramid fiber is a family of synthetic products characterized by strength which is five times stronger than steel on an equal weight basis and heat-resistance and high tensile strength.

**1.4 Properties**

**Table 1.1 Properties of Aramid fiber sheet**

	Description	Test Method	Specification
Property	Weave style plain		Plain
	Areal Weight of Fabric	ASTM D 3801	300
	Standard width (mm)	ASTM D 3774	1000
	Dry Fabric Thickness(mm)	ASTM D 1777	0.25
Characteristics	Warp Fiber- Aramid Fiber		2420 Dtex
	Warp Fiber- Aramid Fiber		2420 Dtex
	Warp Count- Ends per inch		14.8
	Weft Count - Picks per inch		14.8
	Weight Distribution		50% warp : 50% weft
	Density (g/cm3)		1.45
Mechanical Properties of Fiber	Tensile Strength (Mpa)	ASTM D 3039	2400 to 3600
	Tensile Modulus (Gpa)	ASTM D 3039	60 to 120
	Elongation Percentage (%)		2.2 to 4.4

**1.5 Application**

They are used in aerospace and military applications, for ballistic rated body armor Fabric and ballistic composites, High performance, low weight, flexible armor e.g. Body armor Flak jackets. Anti-ballistic composites e.g. mobile screens Helmets Spall linings Primary armor Insert plates Bomb blankets Vehicle armor

**1.6 Types of matrix material**

Fiber, since they cannot transmit loads from one to another have limited use in engineering applications. When they are embedded in Matrix material, to form a composite, the matrix serves to bind the fiber together, transfer load to the fibers and damage due to handling. The matrix has a strong influence on a several mechanical properties of composite such as transverse modulus and strength, shear properties and properties in compression. Physical and chemical characteristics of the matrix such as melting or curing temperature, viscosity and reactivity with fiber influence the choice of fabrication process. The matrix material for a composite system is selected, keeping in view all these factor. Thermoset resin are the most commonly used matrices for production of aramid fiber composite. They are usually available in partially polymerized state with fluid or pasty consistency at room temperature. When mix with proper reagent, they polymerized to become a solid, vitreous material. The reaction can be accelerated by adjusting the temperature. Thermoset resin have several advantages, including low viscosity that allows for a relative easy fiber impregnation, good adhesive property, room temperature polymerization characteristics, good resistance to chemical agents, absence of melting temperature etc. disadvantage are limited range of operating temperature, with the upper bound limit given by the glass transition temperature, poor roughness with respect to fracture (brittle behavior) and sensitivity to moisture during field applications. The most common thermosetting resin for civil engineering are the epoxy resin. Polyester or vinyl ester resin are also used. Considering that the material is mixed directly at the

construction site and obtains its final structural characteristics through a chemical reaction, it should always be handled by specialized personnel.

## 1.7. Advantages and disadvantages

### 1.7.1. Advantages

There have been several important advances in materials and techniques for structural rehabilitation, including a new class of structural materials such as fiber-reinforced polymers (FRP). One such technique for strengthening involves adding external reinforcement in the form of sheets made of aramid fiber. Advanced materials offer the designer a new combination of properties not available from other materials and effective rehabilitation systems. Strengthening structural elements using aramid fiber enables the designer to selectively increase their ductility, flexure, and shear capacity in response to the increasing seismic and service load demands. For columns, wrapping with aramid fiber can significantly improve the strength and ductility.

### 1.7.2. Disadvantages

With the above advantages aramid fiber does also have some disadvantages as follows: The main disadvantage of externally strengthening structures with fiber composite materials is the risk of fire, vandalism or accidental damage, unless the strengthening is protected. As aramid fiber materials are lightweight they tend to pose aerodynamic instability. Retrofitting using fiber composites are more costly than traditional techniques. Experience of the long-term durability of fiber composites is not yet available. This may be a disadvantage for structures for which a very long design life is required but can be overcome by appropriate monitoring. This technique needs highly trained specialists. Moreover, there is a lack of standards and design guides.

## III. EXPERIMENTAL STUDY

### 3.1 Materials

#### 3.1.1 Concrete

Concrete is a composite construction material composed of aggregate, cement and water. There are many formulations that have varied properties. The aggregate is generally coarse gravel or crushed rocks such as limestone, or granite, along with a fine aggregate such as sand. The cement, commonly Portland cement, and other cementitious materials such as fly ash and slag cement, serve as a binder for the aggregate. Various chemical admixtures are also added to achieve varied properties. Water is then mixed with this dry composite which enables it to be shaped (typically poured) and then solidified and hardened into rock-hard strength through a chemical process known as hydration. The water reacts with the cement which bonds the other components together, eventually creating a robust stone-like material. Concrete has relatively high compressive strength, but much lower tensile strength. The ultimate strength of concrete is influenced by the water-cementitious ratio ( $w/c$ ), the design constituents, and the mixing, placement and curing methods employed.

#### 3.1.2 Cement

Cement is a material, generally in powder form, that can be made into a paste usually by the addition of water and, when moulded or poured, will set into a solid mass. Numerous organic compounds used for adhering, or fastening materials, are called cements, but these are classified as adhesives, and the term cement alone means a construction material. The most widely used of the construction cements is Portland cement. It is a bluish-gray

powder obtained by finely grinding the clinker made by strongly heating an intimate mixture of calcareous and argillaceous minerals. The chief raw material is a mixture of high-calcium limestone, known as cement rock, and clay or shale. Blast-furnace slag may also be used in some cements and the cement is called Portland slag cement (PSC). The color of the cement is due chiefly to iron oxide. In the absence of impurities, the color would be white, but neither the color nor the specific gravity is a test of quality.

### 3.1.3 Fine aggregate

Fine aggregate is natural sand which has been washed and sieved to remove particles larger than 5 mm and coarse aggregate is gravel which has been crushed, washed and sieved so that the particles vary from 5 up to 50 mm in size. The fine and coarse aggregate are delivered separately. Because they have to be sieved, a prepared mixture of fine and coarse aggregate is more expensive than natural all-in aggregate. Sand is used for making mortar and concrete and for polishing and sandblasting. Sands containing a little clay are used for making moulds in foundries. Clear sands are employed for filtering water. Sand is sold by the cubic yard (0.76 m<sup>3</sup>) or ton (0.91 metric ton) but is always shipped by weight. The weight varies from 1,538 to 1,842 kg/m<sup>3</sup>, depending on the composition and size of grain. The fine aggregate is passing through 4.75 mm sieve and had a specific gravity of 2.67.

### 3.1.4 Coarse aggregate

Coarse aggregate are the crushed stone is used for making concrete. The commercial stone is quarried, crushed, and graded. Much of the crushed stone used is granite, limestone, and trap rock.. The sizes are from 0.25 to 2.5 in (0.64 to 6.35 cm), although larger sizes may be used for massive concrete aggregate. Machine chorused granite broken stone angular in shape is use as coarse aggregate.

### 3.1.6 Aramid fiber

Aramid Fiber is a composite material made by combining two or more materials to give a new combination of properties. However, aramid fibers different from other composites in that its constituent materials are different at the molecular level and are mechanically separable. The mechanical and physical properties of aramid fiber are controlled by its constituent properties and by structural configurations at micro level. Therefore, the design and analysis of any aramid fiber structural member requires a good knowledge of the material properties, which are dependent on the manufacturing process and the properties of constituent materials.

Aramid fiber composite is a two phased material, hence its anisotropic properties. It is composed of fiber and matrix, which are bonded at interface. Each of these different phases has to perform its required function based on mechanical properties, so that the composite system performs satisfactorily as a whole.

### 3.1.7 Epoxy resin

Epoxy resins are relatively low molecular weight pre-polymers capable of being processed under a variety of conditions. Two important advantages of this resin are over unsaturated polyester resins are: first, they can be partially cured and store in that state and second they exhibit low shrinkage during cure. However, the viscosity of conventional epoxy resin is higher and they are more expensive compare to polyester resins. The cured resin has high chemical, corrosion resistance, good mechanical and thermal properties, outstanding adhesion to a variety of substrate and good electrical properties. Approximately 45% of the total amount of epoxy resin produced is used in protective coating while the remaining is used in structural application such as laminate and composites, tooling, casting, construction, adhesives etc.

3.3 Reinforcement

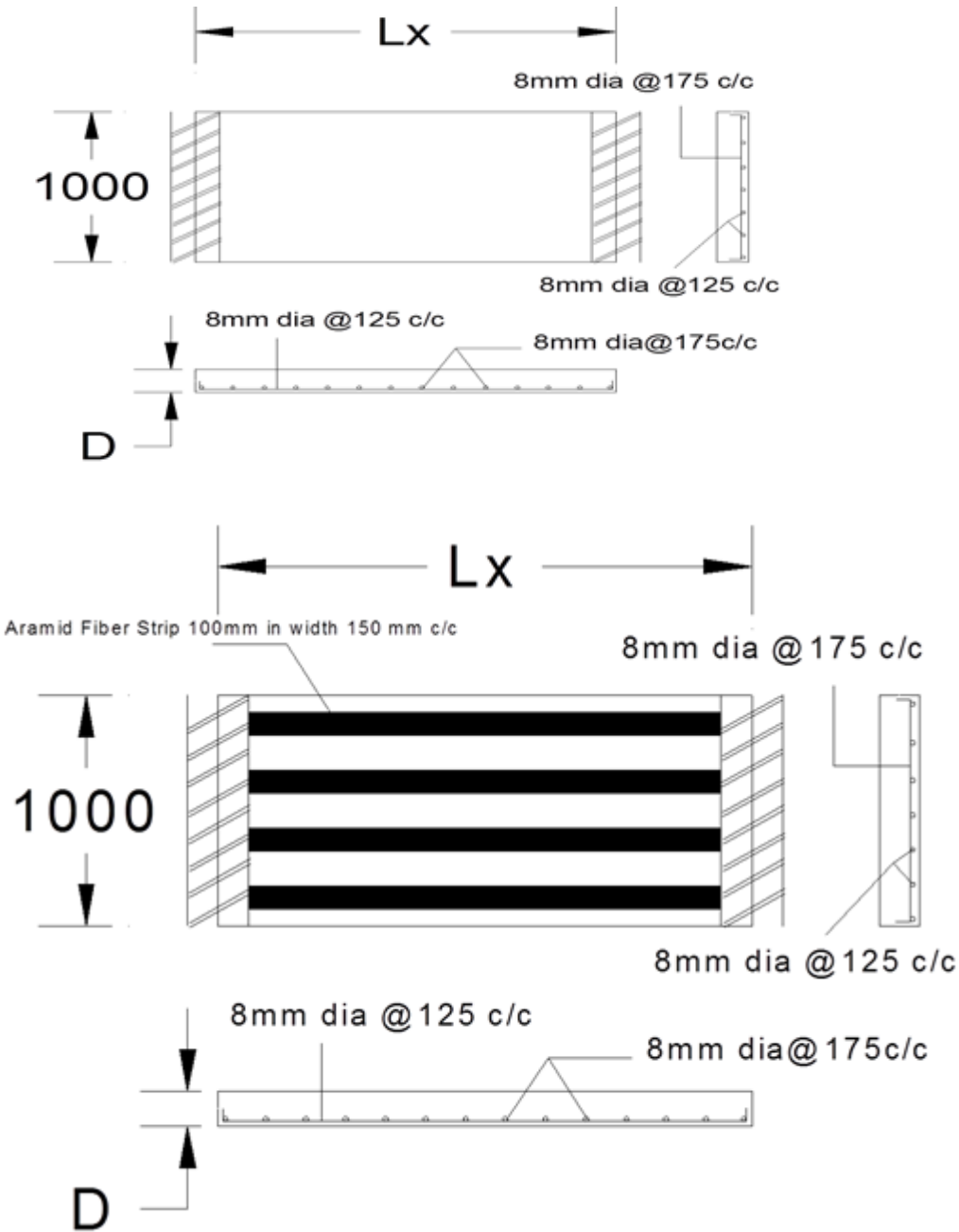
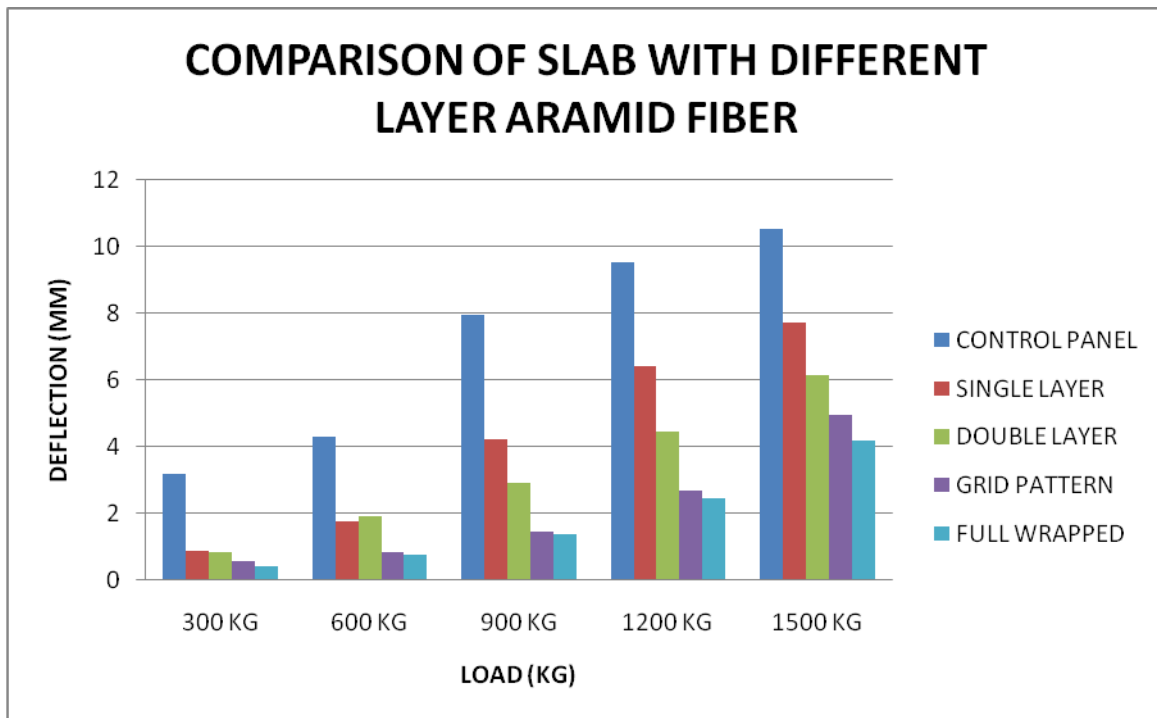

Table No. 3.8 Specimen Detail.

Sr. No.	Type of Wrapping	Designation	Nature Of Slab	No. Of Panel
1	Conventional Specimen	S1	One way	1
2	Specimen wrapped with Aramid Fiber single layer	S2	One way	3

3	Specimen wrapped with Aramid Fiber double layer	S3	One way	3
4	Specimen wrapped with Aramid fibre grid patter	S4	One way	3
5	Specimen wrapped with Aramid Fibre full wrapped	S5	One way	3
		TOTAL		13

**IV. RESULT**



**V.CONCLUSION**

According to the present study it is concluded that there is remarkable increment in strength RC slab. Strengthening refers to the reconstruction or renewal of any part of an existing building to provide better structural capacity like higher strength and ductility than the original building.using Aramid Fiber the strength is increased and it is economical as compare to reconstruction of existing building.

Specimen	Deflection (MM)	% Deflection controlled
Control Specimen	10.52	0%
Single Layer	7.69	27%
Double Layer	6.13	43.74%
Grid Pattern	4.95	52.05%
Full Wrapp	4.17	60.06%

## REFERENCES

- [1] M Jassal & S Ghosh, "Aramid Fiber- an Overview", Indian Journal of Fiber and textile Research, Vol. 27, Sept 2002, pp.290–306.
- [2] Karl k Chang, Du Pont de Nemours & company, Inc., "Aramid Fiber", Constituents Materials, Vol.27, 2005, pp. 41–45.
- [3] DRAGOȘ BANU and N. ȚĂRANU. Traditional solutions for strengthening Reinforced concrete slabs Universitatea Tehnica „Gheorghe Asachi” din Iași Tomul Fasc. 3, 2010.
- [4] G. I. Khaleel, I. G. Shaaban, K. M. Elsayed and, and M. H. Makhlof, Strengthening of Reinforced Concrete Slab-Column Connection Subjected to Punching Shear with FRP Systems. IACSIT International Journal of Engineering and Technology, Vol. 5, No. 6, December 2013.
- [5] Catherine Papanicolaou<sup>1</sup>, Thanasis Triantafyllou<sup>2</sup>, Ioannis Papantoniou<sup>3</sup> and Christos Balioukos<sup>3</sup> Strengthening of two-way reinforced concrete slabs with Textile Reinforced Mortars (TRM) 4th Colloquium on Textile Reinforced Structures (CTRS4)
- [6] Shyh-jiannhwang, Associate Member, ASCE, and Kuan-Yung chanlc (1996) deflection control of two-way reinforced concrete slabs J. Struct. Eng. 1996.122:160-168.
- [7] Renata Kotynia, Krzysztof Lasek and Michal Staskiewicz (2013) Flexural Behavior of Preloaded RC Slabs Strengthened with Prestressed CFRP Laminates ASCE Journal. Compos Construction. 2014.18.
- [8] stijnmattys and luc taerwe concrete slabs reinforced with frp grids. i: one-way bending journal of composites for construction / august 2000 / 145
- [9] Stijn mattys<sup>1</sup> and luc taerwe<sup>2</sup> concrete slabs reinforced with frp grids. punching resistance journal of composites for construction / august 2000/154
- [10] Kai qian, a.m.asce; and bing li.(2013) strengthening and retrofitting of rc flat slabs to Mitigate progressive collapse by externally Bonded CFRP laminates journal of composites for construction © asce july/august 2013/554
- [11] Giovanni loreto, lorenzo leardini, diana arboleda and antonio nanni. performance of rc slab-type elements strengthened with Fabric-reinforced cementitious-matrix composites asce journal Compos Construction. 2014.18