

AGRICULTURAL RECIPROCATING MULTI SPRAYER

Prof. S.V.Deshpande¹, Damre Mayur², Diwanale Swapnil³

¹*Assistant Professors: Department of Mechanical Engineering, GSMCOE, Balewadi, Pune, (India).*

^{2,3}*Students: Department of Mechanical Engineering, Gsmcoe, Balewadi, Pune, (India).*

ABSTRACT

In agricultural sector generally farmer uses traditional way that is spray carried on backpack and spraying crop. This becomes time consuming, costly and human fatigue is major concern, these problems can be overcome by using agricultural reciprocating multi sprayer. It facilitates uniform spread of the chemicals, capable of throwing chemicals at the desired level, precision made nozzle tip for adjustable stream and capable of throwing foggy spray depending on requirement. In our project we use slider crank mechanism to convert rotary motion into reciprocating motion to operate the pump, thus the pesticide is spread through the nozzle. This work gives continuously flow of pesticide at required pressure and height. A special arrangement is implemented in this project to adjust the pressure as high or low. We also use a weed cutter in our model for removing unwanted plants. By using agricultural sprayer, spraying time and weeding time, human efforts reduces and results in cost reduction.

Keywords: *Cost, Nozzles, Pump, Spraying time, Weed cutter.*

I. INTRODUCTION

Generally farmer uses traditional way that is spray carried on backpack and spraying crop this becomes time consuming, costly and human fatigue is major concern. Present day in agriculture the sprayers play an important role in spraying pesticide. Although sprayers varies like motorized, hand operated. Spraying pesticide is an important process in farming. Now days, there are many types of pesticide sprayer already in market. For the different types of pesticide sprayer there are have a different shapes, sizes, method to carry it but the function are same. The current idea on sprayer in our project is to utilize effectively for reducing time of spraying, human efforts and cost of spraying.

The conventional sprayer having some difficulties such as it needs lot of effort to push the liver up and down in order to create the pressure to spray. Another difficulty of petrol sprayer is to need to purchase the fuel which increases the running cost of the sprayer; it produces more vibrations and noise that irritates the farmer and he refuse to do such work repeatedly. In order to overcome these difficulties, we have proposed a wheel driven sprayer, it is a portable device and no need of any fuel to operate, which is easy to move and sprays the pesticide by moving the wheel. The mechanism involve in this sprayer is reciprocating pump, and nozzles which were

connected at the front end of the spraying equipment. A special arrangement is implemented for adjusting the pressure as low and high with the help of adjusting the nut. Also the weeding is done by this equipment. In Agricultural sector use of cheap and beneficial equipment for effective weeding and spraying for increase productivity which is very important for better contribution for India's GDP.

We have to make economic machineries so farmers can purchase it as per capital income of our country's farmers are low and our country per capital income is low that of compared to other country as our country is developing country. Present scenario in agricultural field in India related to sprayer is that farmers are using hand operated sprayer or motorized sprayer. According to idea in our project we are making a small agricultural reciprocating multi sprayer which is mechanically operated by a slider crank mechanism. One vertical arm is attached at in front of cycle and one horizontal arm at top of the vertical arm. Nozzles are fitted to this arm so that it can spray pesticide both the sides. As more no of nozzle are there hence spraying is done rapidly and time and money is saved.

II. PROBLEM STATEMENT

For the backpack type pesticide sprayer, user needs to carry the heavy tank at the back and oscillate the lever that required more efforts. As we know, this is the most type of pesticide pump sprayer that user use in farming. User need to hold the nozzle when spraying out the pesticide.

The second type of spray pump used is fuel operated spray pump, which is heavier than hand operated backpack pump. This type of pump is running on petrol engine. We know that petrol is one of the costly fuel. Also the pump produces more vibrations which is hazardous to users back muscles, these pump makes unwanted noise.

III. SCOPE

Now days the spraying of crop is done by operator taking pump on back, but we were developing this conventional spraying for reducing efforts and time by using slider crank mechanism and motion transmission by chain and sprocket arrangement principles.

IV. CONSTRUCTION

The main components of agricultural reciprocating multi sprayer are as follows:

4.1 Sprockets

The name 'sprocket' applies generally to any wheel upon which radial projections engage a chain passing over it. It is distinguished from a gear in that sprockets are never meshed together directly, and differs from a pulley in that sprockets have teeth and pulleys are smooth. We use freewheel and chain wheel for chain and sprocket arrangement.

4.2 Chain

The chain is made of steel which is used to transmit power from gear sprocket to pinion sprocket, and it has a no sleep.

4.3 Crank

The function of crank is to transfer motion from prime mover to the connecting rod for further operation. Here the circular disc having eccentricity at which rotary motion of crank is converted into reciprocating/linear motion of connecting rod.

4.4 Connecting rod

The main function of connecting rod is to convert rotary motion into reciprocating/linear motion. Here connecting rod convert rotary motion of crank to reciprocating motion of pump and extension rod.

4.5 Pump

It consist of piston and cylinder arrangement, it has a lever to operate the motion of piston in reciprocating direction. The pump generates the pressure of 2 bar and discharge of 2 lpm.

4.6 Nozzle

It is a device which converts the pressure energy of fluid into kinetic energy, spray nozzle is a precision device that facilitates dispersion of liquid into a spray. Nozzle is used for purpose to distribute a liquid over an area.

4.7 Wheel

Wheel is used to carry the whole assembly and move machine from one place to another by rotary motion of it. A bicycle wheel is a wheel, most commonly a wire wheel, designed for a bicycle. Bicycle wheel is designed to fit into the frame and fork via drop outs, and hold bicycle tyre. A typical modern wheel has a metal hub, wire tension spokes and a metal or carbon fiber rim which holds a pneumatic rubber tire. We use a tubeless tire wheel.

4.8 Frame

The main function of frame is to carry whole assembly on it so it has to be strong enough to hold it. The frame is made of square pipe and it is formed out of mild steel.

4.9 Tank

We want our tank to carry as much fluid as it can be along with its self weight as less as possible. We have taken a tank which is almost 16 liter capacity. A material for tank used is plastic fiber. Plastic fiber is very low in weight as compared to other materials. It also has very low cost.

V. WORKING PRINCIPLE and WORKING

Working Principle:

- Motion transmission by chain and sprockets arrangement.
- Slider crank mechanism.
- Rotary motion converted into reciprocating motion.

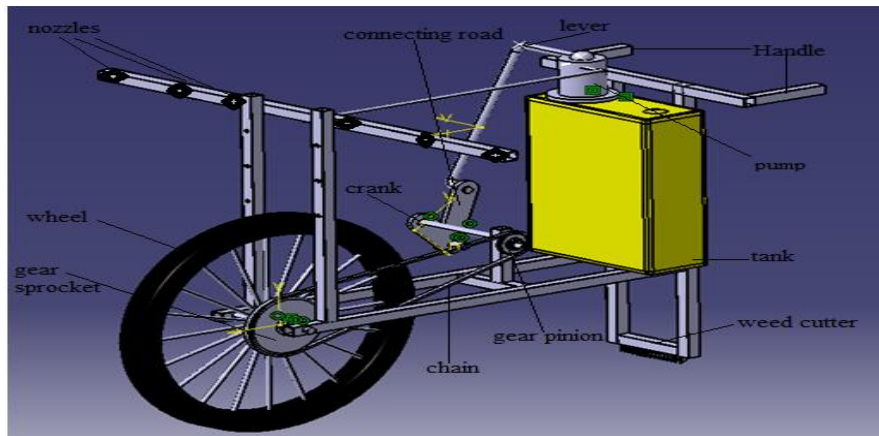

Fig.5.1. agricultural reciprocating multi-sprayer

Above figure shows the assembly of the agricultural reciprocating multi sprayer. The operator grabs the handle and pushes the cycle forward as cycle moves forward, the wheel rotate. When the wheel rotates then the gear sprocket mounted on wheel is also rotate at same speed. The chain drive transfers the motion of gear sprocket to pinion sprocket. The pinion sprocket and crank is mounted on either side of same shaft, the rotary motion of shaft is converted into the reciprocating motion with the help of crank and connecting rod mechanism. The connecting rod is also connected with lever and then the lever oscillates at fulcrum. The piston connected at fulcrum produce reciprocating motion in cylinder and the required pressure is achieved. The pesticide from tank sucks in cylinder and piston forced the pesticide to nozzle through the pipe; the numbers of nozzles are connected to spray the pesticide. We can adjust the pressure, which is required for spraying with the help of special arrangement is to change the length of crank by providing slot on crank. By providing some adjustment at joint of connecting rod and lever free rotation of crank or neutral position can be achieved. Using these adjustments pumping is stop and the wheel rotate freely when you need not spray pesticide. Height, position and angle of the nozzle can be adjustable.

VI. DISTANCE AND HEIGHT OF THE CROP

The distance and height of the crop have been decided after discussing with the farmer and agricultural expertise. We have taken average distance and height of the crop.

Sr. No.	Name of crop	Distance between plant	Height of crop
1	Sorghum	0.70 feet	5.5-7 feet
2	Sugarcane	1 feet	5.5-7 feet
3	Corn	0.35 feet	3-4 feet
4	Pearl millet	0.75 feet	5.5-7 feet
5	Soybean	0.5 feet	1-2 feet
6	Cotton	2-2.5 feet	4-6 feet

Table.6.1:- distance and height of the crop

VII. PART DESIGN

7.1 Selection of Wheel

Distance between two plants = 1.25 feet = 38 cm.

Line covered by one rotation of wheel = 4

$$38 * 4 = 152 \text{ cm}$$

$$152 = 2\pi r$$

$$r = 152/2\pi$$

$$r = 25 \text{ cm}$$

The diameter of wheel = 50 cm

7.2 Selection of Pinion

Minimum no. of teeth available on pinion = 18

Outer dia. Of pinion = 8 cm = 80 mm

Inner dia. Of pinion = 6.5 cm = 65 mm

$$\text{Pitch circle dia. (D}_p) = \frac{D_o - D_i}{2} + (D_i)$$

$$= \frac{80 - 65}{2} + (65)$$

$$D_p = 72.5 \text{ mm}$$

Gear Ratio = 1:3

On rotation of gear sprocket gives three rotation of pinion sprocket, we required three strokes to generate adequate amount of pressure.

7.3 Selection of Gear Sprocket

$$\frac{1}{3} = \frac{t_p}{t_g}$$

$$\frac{1}{3} = \frac{18}{t_g}$$

$$t_g = 18 * 3$$

$$t_g = 54$$

$$\frac{t_p}{t_g} = \frac{D_g}{D_p}$$

$$\frac{3}{1} = \frac{D_g}{72.5}$$

$$D_g = 218 \text{ mm}$$

$$\text{Pitch} = \frac{\text{Number of teeth on pinion}}{\text{pitch circle diameter of pinion}} = \frac{18}{72.5} = 0.25 \text{ mm}$$

7.4 Selection of Chain

Chain type roller chain.

ISO Chain no. 05B

pitch = 0.25 mm

Length of chain , L = K.P

No. of chain ,

$$K = \frac{T_1+T_2}{2} + \frac{2X}{P} + \frac{T_2-T_1}{2\pi} * \frac{P}{X}$$

$$K = \frac{18+54}{2} + \frac{2*478}{0.25} + \frac{(54-18)}{2\pi} * \frac{0.25}{478}$$

$$K = 36 + 3824 + 0.00299$$

$$K = 3860 \text{ mm}$$

$$L = K * P$$

$$L = 3860 * 0.25$$

$$L = 965 \text{ mm}$$

$$L = 96.50 \text{ cm}$$

7.5 Design of Crank and Connecting Rod by Using Synthesis of Mechanism (Three Position Method)

Crank, AB = 5.1 cm

Connecting Rod, BC₁ = 10.8 cm

7.6 Nozzle Selection

Diameter of wheel =50 cm

Let's consider farm of 1 Acre,

Therefore, 1 acre = 4046.86 m²

$$L = \sqrt{4046.86} = 64 \text{ m.}$$

$$\text{Number of plants in 64 meters, } N_p = \frac{64}{0.38} = 168$$

From survey earlier when hand backpack spray pump used then 60 ltr. of pesticide are used for 1 acre farm.

Consider 60 ltr. of pesticide is required for 1 acre farm so how much amount of pesticide is required for one plant

.

Total number of plants in 1 acre, $168 * 168 = 28224$

60 ltr. for 1 acre, $\frac{60}{28224} = 2.1258 * 10^{-3}$ ltr/plant.

Consider time required for 1 acre farm to spray a pesticide is 3 hrs.= 180 minute

$$= 180/28224 = 6.3775 * 10^{-3} \text{ min/plant}$$

$$= 1/6.3775 * 10^{-3} = 156.8 \text{ plant/min.}$$

$$\text{Discharge} = (2.1258 * 10^{-3}) * (156.8)$$

$$\text{Discharge} = 0.3333 \text{ ltr./min.}$$

Find the pressure drop,

$$\left(\frac{Q_2}{Q_1} \right)^2 = \left(\frac{P_2}{P_1} \right) \implies (P_2) = (P_1) * \left(\left(\frac{Q_2}{Q_1} \right)^2 \right) = (2) * \left(\left(\frac{0.3333}{0.4166} \right)^2 \right)$$

$$P_2 = 1.279 \text{ bar}$$

Pressure drop = 0.72 bar

7.7 Design of Manifold and Pipe Selection

When we carry out small sarvay we come to know that various pump are use by different farmers but the most probably use pump is having capacity 16 Ltr. with pressure of 2-4 bars.

Pump Pressure = 2-4 bars

Spray Pipe Material = Plastic

Pump discharge = 2 ltr./min = $3.333 \times 10^{-5} \text{ m}^3/\text{sec}$.

$$Q = A \cdot V$$

$$V = \frac{3.333 \times 10^{-5}}{\left(\frac{\pi}{4}\right) \cdot (d)^2} = \frac{4.244 \times 10^{-5}}{d^2} \text{ m/sec.}$$

Major Losses,

Take a Friction Factor, $f = 0.09$

$$h_{fm} = \frac{(4fLV^2)}{(2gd)} = \frac{(4) \cdot (0.09) \cdot (3.4) \cdot \left(\left(\frac{4.244 \times 10^{-5}}{d^2}\right)^2\right)}{(2) \cdot (9.81) \cdot (d)} = \frac{1.123 \times 10^{-10}}{d^5}$$

Loss at Entry,

$$h_{fE} = \frac{(0.5V^2)}{(2g)} = \frac{(0.5) \cdot \left(\left(\frac{4.244 \times 10^{-5}}{d^2}\right)^2\right)}{(2) \cdot (9.81)} = \frac{4.590 \times 10^{-11}}{d^4}$$

Loss at Out,

$$h_{fO} = \frac{V^2}{2g} = \frac{\left(\frac{4.244 \times 10^{-5}}{d^2}\right)^2}{(2) \cdot (9.81)} = \frac{9.180 \times 10^{-11}}{d^4}$$

Loss at T Section

Take, Bending Coefficient, $k = 0.54$ for 90°

$$h_{fT} = \frac{(KV^2)}{(2g)} = \frac{(0.54) \cdot \left(\left(\frac{4.244 \times 10^{-5}}{d^2}\right)^2\right)}{(2) \cdot (9.81)} = \frac{4.9573 \times 10^{-11}}{d^4}$$

Total Losses, $h_{fT} = h_{fm} + h_{fE} + h_{fO} + h_{fT}$

$$h_{fT} = \left(\frac{1.123 \times 10^{-10}}{d^5}\right) \pm \left(\frac{4.590 \times 10^{-11}}{d^4}\right) \pm \left(\frac{9.180 \times 10^{-11}}{d^4}\right) \pm \left(\frac{4.9573 \times 10^{-11}}{d^4}\right)$$

Required Pressure at nozzle is 2 bar,

Therefore, pressure, $P = 2 \text{ bar} = 2 \times 10^5 \text{ N/m}^2$

$$P = \rho gh$$

$$(2 \times 10^5) = (1000) \cdot (9.81) \cdot (h)$$

$h = 20.38 \text{ m}$ of water

$$\text{Therefore, } h_{fT} = \left(\frac{1.123 \times 10^{-10}}{d^5}\right) \pm \left(\frac{4.590 \times 10^{-11}}{d^4}\right) \pm \left(\frac{9.180 \times 10^{-11}}{d^4}\right) \pm \left(\frac{4.9573 \times 10^{-11}}{d^4}\right)$$

$$20.38 = \left(\frac{1.123 \times 10^{-10}}{d^5}\right) \pm \left(\frac{4.590 \times 10^{-11}}{d^4}\right) \pm \left(\frac{9.180 \times 10^{-11}}{d^4}\right) \pm \left(\frac{4.9573 \times 10^{-11}}{d^4}\right)$$

$$d = 5.611 \times 10^{-3} \text{ m}$$

$$d = 5.61 \text{ mm} = 0.6 \text{ cm}$$

7.8 Selection of Pump

We are going to join six nozzles then pump required to produce the discharge is,

$$(6) * (0.3333) = 2 \text{ lpm.}$$

Total discharge of pump is 2 lpm.

For above discharge, which pump give pressure above 2 bar is to be selected.

7.9 Design of Frame

Length of frame = (centre dist. between two sprockets) + (width of tank) + (Excess)

$$= 478 + 130 + 242$$

$$L = 850 \text{ mm}$$

Height of Frame = 776 mm

Width of Frame = 500 mm

Total length of pipe = $(850 * 2) + (200) + (600 * 2) + (1000) + (775 * 2) + (100) = 5750 \text{ mm}$

cross section area of square pipe = $25.2 * 2 = 51 * 4 \text{ sides} = 204 \text{ mm}^2$

volume of frame = $204 * 5750 = 1173000 \text{ mm}^3$

Density of m.s.material = $7.7 * 10^{-6} \text{ kg/mm}^3$

$$\text{Density} = \frac{\text{mass}}{\text{volume}}$$

Mass = density * volume

$$= (7.7 * 10^{-6}) * (1173000)$$

$$= 9.03 \text{ kg}$$

Total weight of assembly = $15 + 2 + 1 + 9 = 27 \text{ kg} * 9.81 = 264.87 \text{ N}$

Yield stress of material = 247 N/mm^2

Area = $5750 * 25.4 = 146050 \text{ mm}^2$

$$\text{Stress} = \frac{\text{Load}}{\text{Area}} = \frac{264.87}{146050} = 0.0181 \text{ N/mm}^2$$

Therefore, $0.0181 < 247 \text{ N/mm}^2$, hence the design is safe.

VIII. CONCLUSION

It is upgraded design of manually operated sprayer and weeder which will be helpful for small land farmers. It consumes less time and saves money as compared with conventional spraying and weeding.

This machine does not require any fuel or power so maintenance is less. This model removes problem of back pain, vibrations and noise.

This alone pump can used for multiple crops.

The model has provided multiple nozzles, which has continuous spray over crop and this process takes less time than other sprayers for spaying.

IX ACKNOWLEDGMENT

We would like to express our gratitude and appreciation to all those who gave us the possibility to complete this report. A special thanks to our Guide Prof. S.V.Deshpande whose help, stimulating suggestions and encouragement, helped us to coordinate our paper especially in writing this paper. We would to appreciate the guidance given by other supervisor as well as the panels especially in our paper that has improved our presentation skills by their comment and tips.

REFERENCES

Journal Papers

- [1] Prof. Sumit D. Raut, Prof. Kamlesh R. Banarse, Prof. Roshan R. More, “*Fabrication of pedal operated pesticide sprayer for agricultural and drainage line use*”, *IJPRET*, Volume 2(9): 67-74, ISSN 2319-507X, Issue 01, June 2014
- [2] Shivaraja kumar. A, Parameswaramurthy. D, “*Design and development of wheel and pedal operated sprayer*”, *IPASJ International Journal of Mechanical Engineering (IIJME)*, ISSN 2321-6441, Volume 2, Issue 06, June 2014
- [3] S R Kulkarni, R V Nyamagoud, Hareesh Naik, and Mohan Futane, “*Fabrication of Portable Foot Operated Agricultural Fertilizers and Pesticides Spraying Pump*”, *International Journal of Engineering Research & Technology (IJERT)*, ISSN: 2278-0181, Vol. 4 Issue 07, July-2015

Theses :

- [4] David McAuliffe and Vanessa P. Gray, *Application Technology: “Problems and Opportunities with Knapsack Sprayers, Including the CF Valve™ or Constant Flow Valve”*.