

## RESISTANCE WELDING PROCESS

**Jatoth Ramachander<sup>1</sup>**

*HOD & Sr. Assistant Professor of Mechanical engineering , S.V.Engg.college Suryapet (India)*

### ABSTRACT

*This paper discourse resistance welding under the course advanced manufacturing processes. In the previous session, we have discussed about submerged arc welding, but this is a new welding technique in which no arc will be used. In a way, this is away from the conventional welding processes, where either flame or arcs are used. In this purely electrical energy will be used for getting the heat at the welded joint. Therefore, it can also be termed as a green technique for metal joining. In which no arc will be used or no flames will be used or no gases will be burnt.*

### I INTRODUCTION

In this process uses the holmic Heating principle. In which if we connect a source of electrical energy to a load. Load is basically in the form of a resistor, which we call as R the resistance R, and this is say voltage V is applied across this load which causes current i to flow.



$$H = i^2 R t \text{ joules}$$

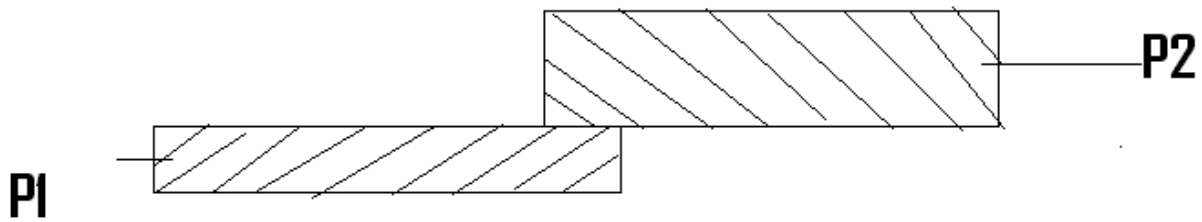

This is a simple circuit electrical circuit. In which voltage  $v$  is applied through the load  $R$  in which current  $i$  is flowing. Now the heat developed in this can be represented as  $H$  equal to  $i^2 R$  and then  $t$ ;  $t$  is the time;  $i$  is the current flowing through the circuit,  $R$  is the load which can be an element heating element. We can think of this is a heating element across which this voltage  $V$  is being applied. Because of this, while it is the current  $i$  is kept on flown over a period time then the corresponding heat developed can be represented mathematically as  $H$  equal to  $i^2 R t$ . So, this will be in terms of joules; this is also called ohmic heating. And this heat, in principle will be used for causing the material to melt and then fuse together to form the joint.

$$H = i^2 R t \text{ joules}$$

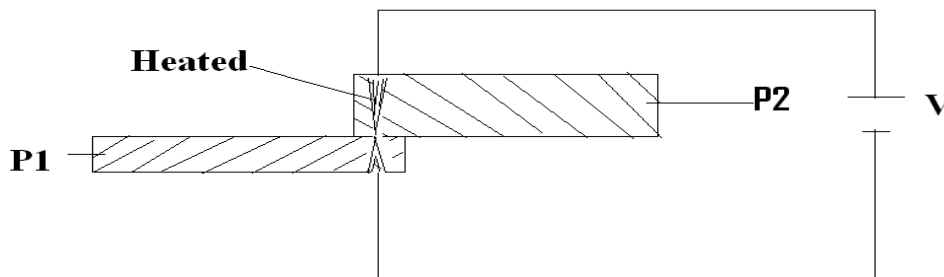

Thus if the two materials to be joined are like this, these are the two plates to be joined or the materials to be joined. Say this is plate P 1 and this is plate P 2, and they are connected to an external source of energy or the electrical energy or voltage  $v$ . Then current flowing through them will be will because this portion to get heated, because of the resistance  $R$ . This portion will get heated. And if the heat is so intense, that it is capable of melting this material in the vicinity of this then this might cause a melting and fusion of the material in this zone and the joining of the plates can take place. This is the basic principle being used in this process.

## II RESISTANCE WELDING

Let us see the different aspects of this process in details. This process makes use of the electrical resistance of the generating heat for melting the work piece as we have already discussed. It is generally used for joining thin plates and structures.

The resistance welding process can be considered a green process, since it does not generate gases and flames, as in the case of metal arc welding and gas welding. Thus it is an environment friendly process and it uses renewable energy resource. The process reduces operators fatigue to a great extent. The process can also be easily automated. The variant of resistance welding, called as stud welding is used to weld studs or bolts and bosses to the oil tanks in hydraulic applications. Stud welding helps to join these components in one shot, which reduces valuable time, gives

uniform welding joints and automates the process. The seam welding can produce continuous fast and leak proof-welds mainly used for thin metallic sheets, galvanized roofing, small tanks etcetera.

The heat generated in resistance welding is given by the equation:

$$H = K * I^2 * R t$$

Where, H =heat generated in joules

K=constant

I = Current in Amperes

R = Resistance of the joint

t = time of flow of current, S

The heat generated in resistance welding is given by mathematically H equal to K times I square R T where K is the constant. In fact, heat generated is proportional to square of the current flowing through the circuit, also proportional to the resistance through which the current is flowing, and the time of flow of current. This is what we have discussed in the early part of this session. The resistance R depends on several factors and it represents the combined resistance of the work pieces to be joined, the electrodes used, and the gap resistance. The constant K, on the other hand depends on the materials to be joined, the work piece thickness, the electrodes used, and resistance.

The critical variable in a resistance welding process is the contact resistance between the two work piece plates and their resistance themselves. The contact resistance is affected by the surface finish of the plates, since the rougher surfaces have higher contact resistance. This point can be explained like this. Say for example, two surfaces are meeting like this. Then the resistance between them when we apply some voltage across them, say v. This portion the resistance in this portion as we have already indicated this as r will depend on the interface characteristics say this portion. How they are together mating together like wherever their contact is very intimate like this or whether they are contacting something like this. Now here as we can see in this portion this material to material, so this is also work-material and this is also work material. Now material-to-material contact is restricted by the roughness of the surfaces. This is the roughness of the surface and this is the roughness of this surface.

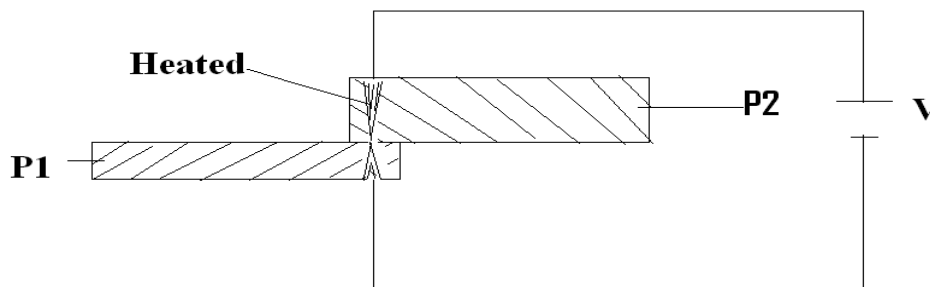

Now we can imagine at the same or we can very easily understand that as this roughness becomes less or the surfaces become smoother. These two surfaces will come very closely to each other, and thereby this contact will become better. And therefore, the resistance between them will be less. So, here whatever the resistance will be offered by this, say  $R_1$  will be definitely higher than the resistance  $R_2$  as in this case. The contact resistance is also affected by the cleanliness of the surface. Oxides or other contaminants if present should be removed prior to attempting the resistance welding. The lower resistance of the joints requires very high current to provide enough heat to melt it.

The average resistance may be of the order of 100 micro ohms; as a result, the current required would be of the order of tens of thousands of amperes. Thus with a 10,000 ampere current passing this 100 micro ohm resistance for 0.1 second, the heat liberated will be equivalent to 1000 joule or 1 kilo joule which can be calculated mathematically as shown in the screen. This is typical for the welding of 1 mm thick sheets. The actual heat required for melting assuming weld area as a cylinder of 5-millimeter diameter and 1.5 millimeter height would be of the order of 340 joules. The remaining heat is actually utilized in heating the surrounding areas and gets wasted at other points.

Resistance welding has different variants such as seam welding, projection welding, and spot welding. A resistance welding is the sequence of events that normally takes place in each of the welds. These events are as follows: number one - the squeeze time. Squeeze time is the time required for electrodes to align and clamp the work pieces together and provide necessary electrical contact. Next is the weld time. This is the time the current flows through the work piece till they are heated to the melting temperature. And the next event is the hold-time. The hold time is the time till the pressure is maintained without the current, wherein the pieces are expected to get forge welded. Next event is off-time. The off time is when the pressure of the electrode is taken off, so that the plates can be positioned for next spot. It is specified when a series of spots are to be made in a predetermined pitch.

Let us identify distinct advantages of resistance welding process over other welding processes. There have been a number of distinct advantages that account for their wide use, particularly in mass productions environment. Resistance welding process is very rapid in operation. The equipment required for this process can be fully automated. Thus these are clearly some advantages.

The resistance welding process conserve materials as no filler metal is required, shielding gases or flux these materials are also not required. Skilled operators are also not required, because this mostly this will be controlled by a machine only or the electrical control system. The dissimilar metals can be easily joined by this process. A high degree of reliability and reproducibility can be achieved in this process. Therefore, clearly this process is advantages to many of the conventional processes. Let us identify the limitations of this resistance welding process as well. Although the process has several advantages such as non-production of toxic gases which is clearly an indication of environment friendly process. It has however some limitations as mentioned below. Number one - the equipment

has a high initial cost; this restricted to fewer types of joints that can be made mostly lap joints, as we have already seen in the schematic as well.

Skilled maintenance persons are required to service the control equipment. Some materials require special surface preparations prior to welding. As we have already discussed, the surface roughness of the two plates or the surfaces to be joined plays an important role in resistance welding process. Not only surface roughness, but the cleanliness of the surface that also influences the process. If there are certain materials which has got low resistance a low current conducting capacity or high resistance then also the joint melting temperature will be different for the same amount of current flown through that. Therefore, this process requires careful treatment of the, or preparation of the surfaces to be joint. Now, let us talk about upset welding. In this process, the pieces to be joined are brought together to mate each in a butt joint compared to lap joint. The pieces are tightly held together and current is applied, so that heat is generated through the contact area between the two plates.

Since the joint is under pressure, the ends of the two pieces get slightly upset, hence the name upset welding is given. This is useful for joining two rods of similar pieces. A variation of upset welding is a continuous seam welding, used to make electric resistant welded pipes, also known as ERW pipes. Now, let us move on to resistance seam welding. This is another variant process of resistance welding, wherein a seam of continuous welds can be generated. This resembles the seam of a cricket ball. The seam consists of a series of overlapping spot welds. These are made by distinct processes. In one case, the weld is made between overlapping sheets of metal and the process is used to produce liquid or gas tight sheet metal vessels, such as gasoline tanks, automobile mufflers and heat exchangers.

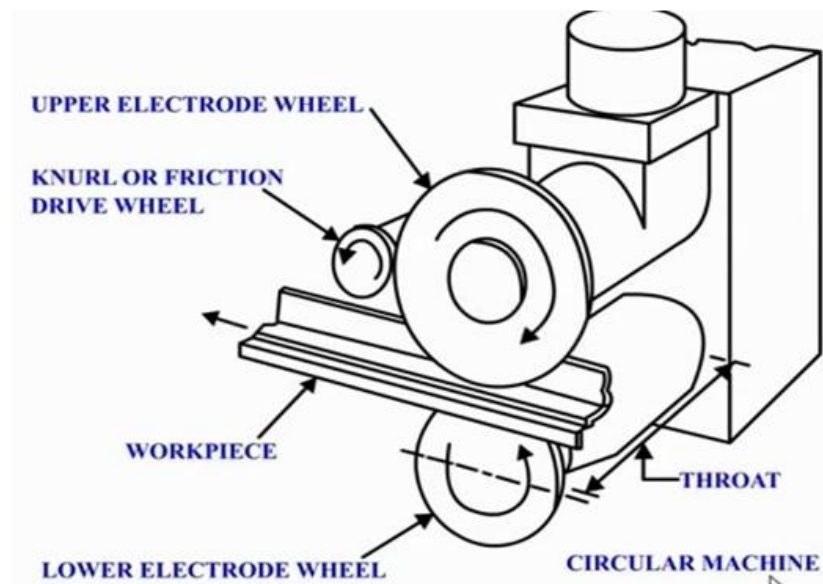
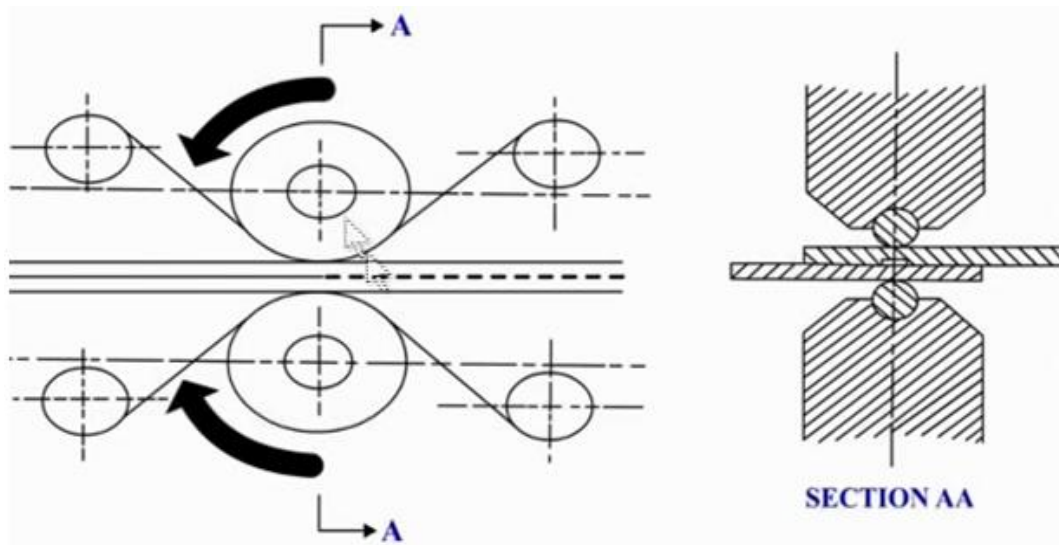

Figure: Schematic of the resistance seam welding process

As the metal passes between the electrodes timed pulses of current pass through it to form the overlapping welds. The timing of the welds and the movement of the works is controlled to assure that the welds overlap and the work piece do not get too hot. The welding current is usually higher than the conventional spot welding current. In order to compensate for the short circuit of the adjacent welds, external cooling of the work by air or water is often employed. In a variation process, a continuous seam is produced by passing a continuous current through the rotating electrodes. The typical welding speed is about 60 inch per minute for thin sheets.

The schematic of the resistance welding process is shown in this figure. So, this figure is in the screen in which this two welds as we can see forms two electrodes through which the current will be passed. And the plates to be joined are placed in between. Therefore, the current passing through this contact points, because of the voltage applied across them will get heated and melted, and they will get fused and will form a seam sort of as can be seen in this figure. Schematic of the electric wire seam welding process, which is a variant of resistance welding process, is shown here. So, in the same way two welds which are used as the electrodes. The currents, the current is passed through this and the plates to be joined are passing through this. And therefore, the joint will be formed at the point through which the current will be passed and the ice bar or heating will takes place. As can be seen clearly in this particular view which is a section at this AA.



**Figure: Schematic of the Electrode Wire Seam Welding Process**

The next figure shows different types of seam weld joints where lap seam weld, mash seam weld and metal seam weld are depicted.

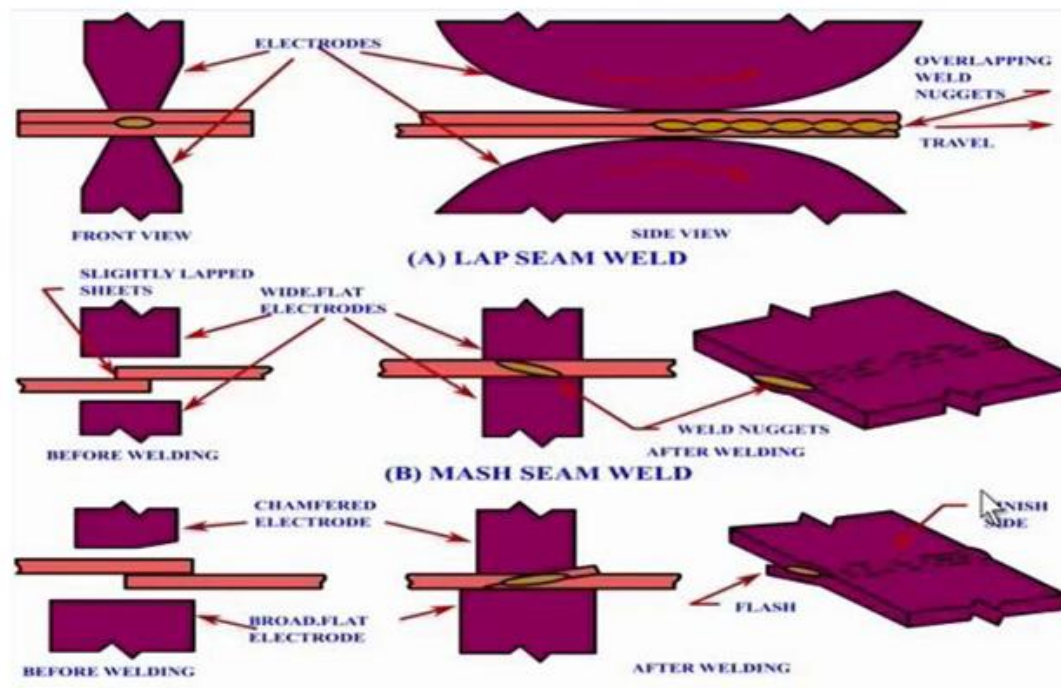

**Figure: Metal finish seam weld**

This is a case of lap seam weld joint, in which two plates are completely lapped on each other and the other two welds form the electrodes. And therefore, the point between them or the point of contact or area of contact between these two welds, which facilitates the current to flow through them gets heated, because of the ohmic heating or arc bar or heating and gets welded. So, this can be seen here as well. This view of the same scheme. In this case, mash seam weld the plates are placed as can be seen here slightly lapped configuration. And other things welded electrodes are placed as it is and the weld nuggets will form as shown in this figure. The third configuration is the metal finish seam weld in which the electrodes one of the electrodes is made chamfered. Thereby the contact between the plates to be joined and the electrodes are made different. And this produces a nugget weld nugget as can be seen in this figure, and correspondingly the seam produced will be like this. The two plates, these are the two base plates, these are the joint and this is the seam being produced because of this resistance welding.

The second type of resistance seam welding is used to make butt welds between thicker metal plates. In this process, the electrical resistance of the abutting metal is used to generate heat. A high frequency current up to 450 kilo hertz is employed to restrict the flow of current to the surfaces to be joined and to their intermediate surroundings. The combination of high frequency current and high welding speed produces a very narrow heat affected zone. This is another aspect as everybody knows welding is a process where heat affected zone is most likely; however, in most of the cases this is another aspect which a welder ones not to occur. So, here is the process where we can control the parameters in such a way that this heat affected zone can be minimized to a very, very thin zone. This is a clearly

advantages of this particular process. Now let us look into the applications of this process. The most extensively used resistance butt-welding is in the manufacturing of pipes and tubes and simple structural shapes which can be produced from plates. Materials from 0.13-millimeter thickness to more than 19-millimeter thickness can be welded up to 82 meter per minute speed, which is quite high. Almost all types of materials can be welded by this process.

Dissimilar metals can be welded and high conductivity metals such as aluminum and copper can also be welded by this process, however, in this case as we have already discussed. For high connectivity resistance will be less, and therefore, to get the same edge or the heat energy which will be ultimately responsible for melting the material and causing the bonding will be less. And therefore, to compensate for that reduced R, one has to apply higher degree of current to obtain the same heat which will cause melting of the materials. Now let us move on to another welding process known as flash welding. It is similar to upset welding, except that the heat required for melting is obtained by means of an arc rather than the simple resistance heating. The equipment consist of two plates to which two pieces to be joined or clamped; one plate is fixed, the other is movable this can be seen in this particular figure. So, the left one is the fixed platen, the other one is the movable one, and between these two the arc is being produced and therefore, the heating in these ends will take place and these two ends can be fused together by application of some pressure. That pressure can be applied through this cam mechanism, which will cause this particular platen to move against this fixed platen. And therefore, there will be a pressure generated here which will cause fusing of these two ends under the intense heat because of the arc.

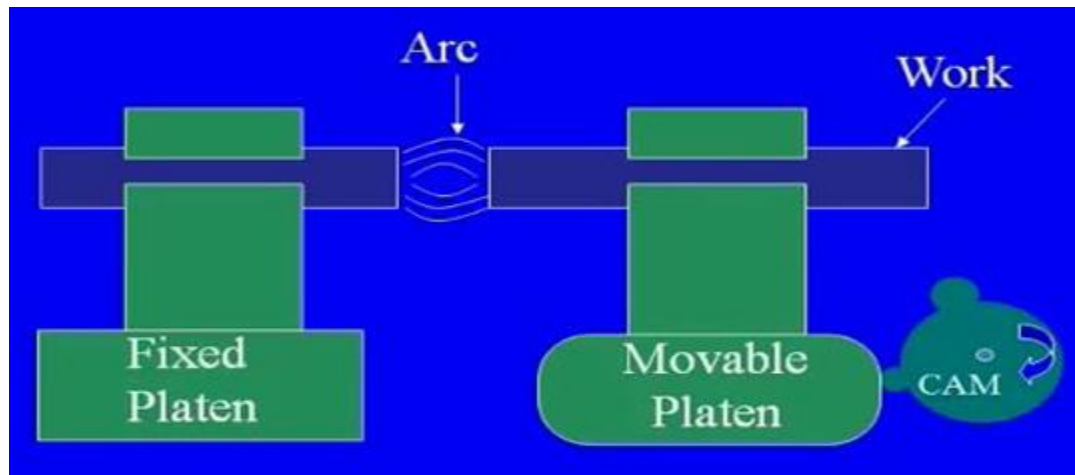

**Figure: Schematic of Flash Welding**

The ends of the two pieces need to be parallel in this case. The two pieces are brought together and the power is switched on. Momentarily the two pieces are separated to create an arc to melt the ends of the two pieces. Then again the two pieces are brought together. The power is switched off while the two ends are fused under force. Most of the metal melted would flash out through the joint and forms like a fin around the joint. So, this will be like this.

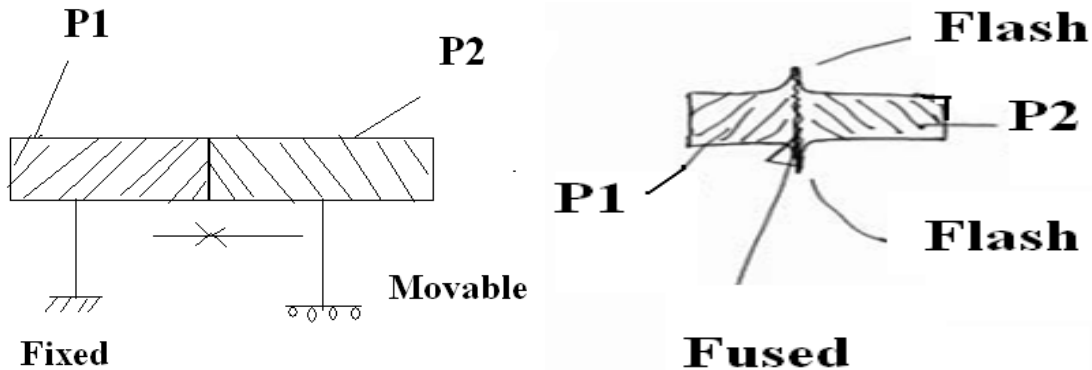

If these are the two ends to be joined and they are highly parallel. Then this is material one and this is material two to be joined. Then they are brought together from this side or applying pressure like this, in which case one can be made fixed. So, this can be fixed, while the other can be made movable. And they will be placed against the fixed one, this is the fixed one and this is the movable one by some suitable cam mechanism etcetera. Initially, they will be touched for a moment and then again this engaged or detached which will cause an arc to produce. This will cause these two ends to get melted, because of the intense heat of the arc being produced here and since they are already under pressure. So, these two ends will produce some flash something like this. In which, this is the material one and this is the material two, and this is something like flashes being produced, flashes being produced. This is piece one and this is piece two. So, here piece one and this is piece two and this is fused at this point. Now let us move on to another welding technique that is projection welding. The principle of this process goes like this. This is shown in the figure - next figure, a dimple is embossed into one of the work pieces at the locations where the weld is desired. The work pieces are then placed between large area electrodes this is like this.

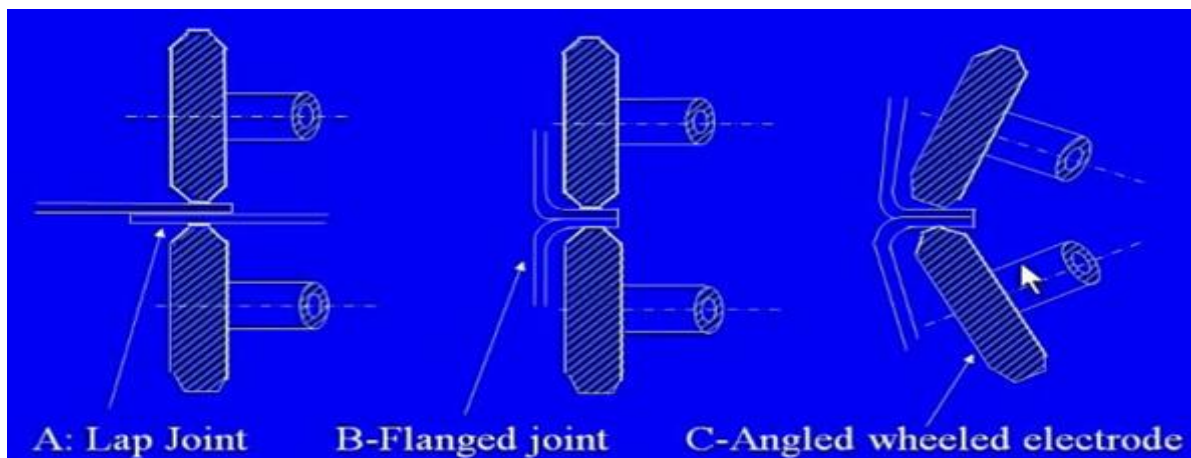

Figure: Types of Projection Welding

These are nothing but the electrodes as shown in the screen. And these are the two plates to be joined here, they are overlapped like this. And this can be joined at this point. In different configurations, they can be joined; this is a flanged joint and this is angled weld electrode which can be employed in this configuration as well. The pressure and current are applied as in the spot welding process, that we have already discussed. This current will be ultimately responsible for causing the ohmic heating on the load and load is nothing but the joint of the two materials. Since, the current must flow through the point of contact, namely the dimples, the heating is concentrated where the weld is desired. As the metal heats and becomes plastic, pressure causes the dimple to flatten and form a weld. Since the projections are press formed, they can often be produced during other blanking and forming operations with virtually no additional cost. Next figure shows some projection weld designs for leak type joints in fasteners.

These are some of the joints. This is in case of threaded boss. So, this is the threaded portion; this is the boss and here the welding will be taking place in these points. Similarly, some projections are being created here as can be seen in this figure. So, these are the clear projections and the joints or the welding will take place across these projections and weld will be formed here. This is also called shoulder stud.

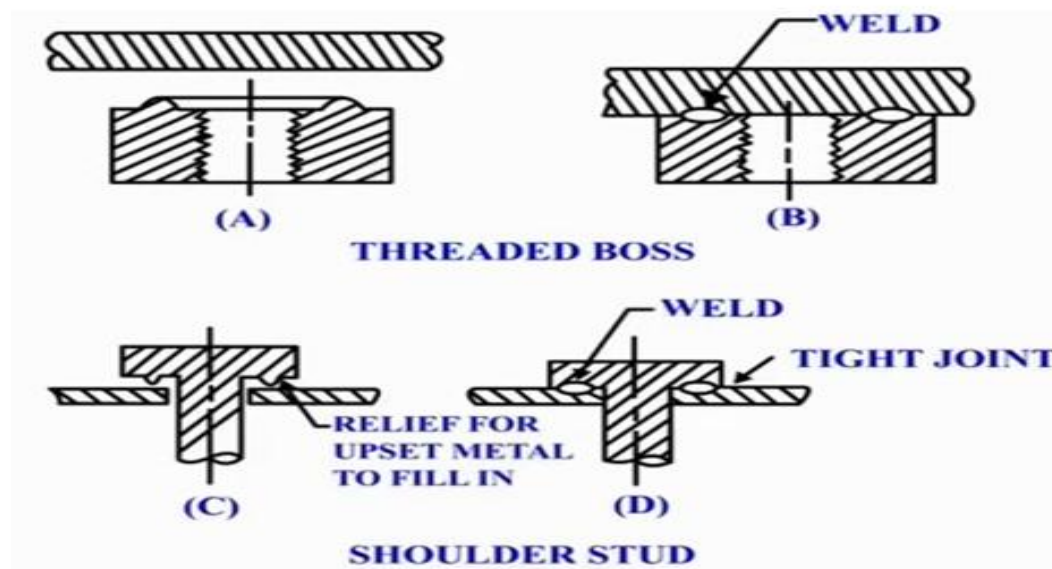

Figure: Projection Welding Design

### III ADVANTAGES

The advantages of this process

- Dimples and projections can be made in almost any shapes such as the round, oval or circular in order in order to produce the welds of shapes to suit various design purposes.

- Several dimples can be incorporated into the sheet and multiple welds can be made at a given time.
- By changing the size and shape of the electrodes, the conventional spot welding machine can be changed into a projection welding machine.
- Projection welding leaves no indentation mark on the free surface.
- This is an clear advantage of this process. This is a very distinct advantage over spot welding when good appearance is required.

## IV APPLICATIONS

The applications of this particular process

- Several joints can be made with multiple spots as per required applications.
- Nuts, bolts can be attached to other metal parts by projection welding.
- Contact is made at a projection that has been machined or forged onto the bolt or nut.
- Next, current is applied and the pieces are pressed together to form a weld.
- It is an attractive means of mass production.
- Multiple welds can be made with additional strength.
- This helps in improving the shortcomings of a conventional spot where one spot is made at a time.

## RESISTANCE SPOT WELDING

They have a quick look at the resistance spot welding.

- The individual welds are produced in this method by momentary application of pressure and resistance into the work piece.
- The work pieces are held together under pressure between the anvil faces.
- The machine is started which applies current and the resistance is generated at the point of contact. Spot weld between sheets are roughly elliptical at the interface.
- They can be overlapped to produce an essentially continuous weld joint.

## APPLICATION OF SPOT WELDING

Then applications of spot welding are

- It is used for joining similar or dissimilar metals, where continuous weld joint is not required.
- It is commonly used in sheet metals.
- It is also used in joining metallic bucket-handles.
- This is very frequently used in batteries of nickel cadmium cells.

- This also used for metallic joints in dentistry and medical instruments.
- For joining of utensil handles, this technique is used frequently.
- metallic toys

## V SUMMARY

The summarize what we have studied in this particular section. In this section, we have discussed about the principle of resistance welding process its features and other details. The variant processes of resistance welding process, namely the seam welding, projection welding and spot welding have also been discussed. We hope this section was interesting and useful.

## REFERENCES

1. K.Middeldorf and D. von Hofe // Paton Welding Journal 11 (2008)
2. S. Sasabe, In: Proc. of Committee of Joining and Material Processing for Light Structures of Japan Welding Society MP-391-2006 (2006)
3. B. Pekkari // Welding in the World 44 (2000) 101
4. T. Ueyama // Welding International 24 (2010) 699.
5. [www.amada.com](http://www.amada.com)
6. [www.efunda.com](http://www.efunda.com)