

Automation and Monitoring Smart Kitchen using IOT

¹G. Mallikarjuna Rao, ²Y. Bhavana, ³T. Vinod Kumar, ⁴Sd. Khashira, ⁵P. Sushma

¹Associate Professor Department of ECE, Tirumala Engineering College,
^{2,3,4,5} U.G Student Department of ECE, Tirumala Engineering College,
Narasaraopet, Palnadu Dist. Andhra Pradesh, India,522601.

Abstract—This project aims to develop a smart home kitchen system using Arduino and GSM technology to improve safety and convenience. The system includes sensors for monitoring gas weight, detecting gasleaks, detecting fires, and measuring distances. Alerts are sent via GSM to the homeowner's mobile phone in case of gas leaks or fires, enabling quick response and prevention of potential hazards. The integration of these sensors with Arduino allows for real-time monitoring and control of the kitchen environment, enhancing safety and peace of mind for home owners.

I. INTRODUCTION

With the advancement of technology, smart home solutions have become increasingly popular, offering convenience, security, and energy efficiency. The kitchen, being a high-risk area due to the presence of gas and fire hazards, can greatly benefit from smart automation. This project aims to create a smart kitchen system that integrates various sensors with Arduino to monitor and respond to potential dangers. The project scope includes designing and implementing a system that can accurately measure gas weight, detect gas leakage, detect fire, and measure distances using an ultrasonic sensor. The system will use GSM technology to send alerts to the homeowner's mobile phone in case of gas leakage or fire, enabling quick action to mitigate risks. Traditional kitchen safety systems rely on manual intervention or standalone sensors that do not communicate with each other or with the homeowner. This can lead to delays in detecting and responding to hazards, increasing the risk of accidents. The proposed smart kitchen system integrates multiple sensors with Arduino to create a cohesive monitoring and alert system. The gas weight sensor continuously monitors the gas cylinder's weight, alerting the homeowner when it reaches a certain threshold to prevent unexpected gas depletion. The gas leakage sensor detects any leaks and triggers an alert, while the fire sensor detects flames or high temperatures, initiating an immediate alert and potentially triggering safety mechanisms such as shutting off gas valves. By integrating sensors with Arduino and GSM technology, this project aims to enhance kitchen safety and convenience. The system's ability to detect gas leakage, monitor gas weight, and detect fires, combined with its alert capabilities, can help prevent accidents and save lives. The project demonstrates the potential of smart home solutions in improving safety and convenience in everyday life.

In the future, the system could be expanded to include additional sensors for monitoring other aspects of the kitchen environment, such as temperature, humidity, and air quality. Integration with other smart home devices and systems could also enhance the system's functionality, such as automatically shutting off appliances in case of emergencies.

II. RELATED WORK

Home automation or smart homes can be described as introduction of technology within the home environment to provide convenience, comfort, security and energy efficiency to its occupants. With the introduction of IoT, the research and implementation of home automation are getting more popular. Various wireless technologies that can support some form of remote data transfer, sensing and control such as Bluetooth, wifi, Rfid and cellular network have been utilised to embed various levels of intelligence in the home. The studies have presented Bluetooth based home automation system using android smart phones without the internet controllability. The devices are physically connected to Bluetooth sub controller which is then accessed and controlled by smart phone using built in Bluetooth connectivity. Researchers have also attempted to provide a network interoperability and remote access to control devices and appliances at home using home gateways. Lately few researchers have also presented the use of Web services , simple object access protocol (SOAP) and representational state transfer as an interoperable application layer to remotely access home automation system

III. LITERATURE REVIEW

In this section, research efforts related to the Internet of Things are discussed. IoT is used for monitoring and automating the smart kitchen and smart homes. The Internet of Things (IoT) is an extension of the current Internet that allows gadgets or physical items to communicate, interact, and use the Internet. To aid management and mitigate the dangers associated with IoT smart homes, smart homes require a dependable, simple, and autonomous network infrastructure. A previous article describes the present state of the Internet of Things and smart homes, and the trends in their growth, and closely investigates the security issues in smart homes . A smart home system ensures the security and safety of the owner's house. It protects against gas leakage, detects fire, enables room temperature and humidity monitoring, and detects water overflow from roof tanks. The aim of the suggested system is to create a safe home system by making accessibility simpler for handicapped persons, especially youngsters and the elderly . The dynamics enabled by the introduction of the IoT in the furniture and kitchen production industries, are discussed in . In , the author designed an IoT-based smart kitchen wardrobe control system. The system was designed and developed using an Arduino and a mobile application. The grocery products in a kitchen must be manually monitored, and the user must make decisions . Grocery shopping can now be undertaken online. However, keeping track of the goods is the primary responsibility of the person in charge of the kitchen; failure to do so will result in a lack of ingredients. The authors of imagined an automated system using IoT technology to for home

automation system and monitor kitchen groceries and cooking ingredients. The IoT is widely used for smart kitchens. In author use the IoT for home grocery monitoring system as the sensors are involved to sense the behaviors associated with grocery replenishment, and to analyze the data to track and predict the grocery demand for a smart kitchen. Many intelligent and smart safety and security systems for kitchens have been proposed by researchers. There is now an important need to ensure the kitchen's safety and security. Systems have been designed to give users a variety of options for checking, managing, controlling, and monitoring kitchen data. To monitor the kitchen, researchers have incorporated a variety of technologies, such as sensors, ZigBee, databases, embedded tools, Web applications, and mobile development used. In a smart and safety monitoring system is powered by the following sensors: a DTH11 sensor monitors the humidity and temperature of the kitchen; an IR flame sensor detects the presence of fire in the kitchen's surroundings; and an MQ-3 sensor detects any gas leakage in the kitchen. Gas leakage is a major issue in kitchens and causes many problems, such as the spread of fire. Because the spread of a fire can often lead to significant loss of life and property damage, early detection of fire sources, and identifying effective remedies, have become critical challenges in fire prevention and property protection. Thus, refs investigated kitchen gas leakage issues, and the investigators proposed an IoT-based kitchen gas leakage management and control system to manage kitchen safety. To address kitchen safety issues, the authors of placed Internet protocol cameras, so that residents can monitor the gas stove from their phones, and used an alarm to alert the occupants. In the author proposed a home automation system to make it easier for handi capped people. A live monitoring system provided real-time updates on the energy usage of a room or a hall. The system was built around a few sensors and detectors that were integrated with a Raspberry Pi. Authors have used a Raspberry Pi and an Arduino with an Android app for home automation and monitoring systems, respectively. The design challenges of home automation have become more apparent as technology has become more invasive. Home automation, in addition to surveillance system security based on IoT, are important because home automation, monitoring, and programming by the end user have yet to become commonplace. Artificial intelligence applications in smart kitchens' automation systems have been designed and used in everyday kitchen appliances. Temperature and weight sensors are part of the automation system. A developed system

continues to monitor kitchen services; the smart kitchen prototype is placed in a miniature kitchen, and the layout of each indicator and sensor is adjusted to the actual system condition to control the kitchen appliance. IoT-based smart kitchens with automation and monitoring systems, including for the smart home, smart city, smart grid, smart health, and smart kitchen, have been developed. The IoT-based smart kitchen has been examined, including its importance for safety and security, particularly for children and adults, and the smart kitchen's various roles. The Nuvoton smart kitchen system was designed. The smart kitchen system includes subsystems such as a gas leak detection system and a fire extinguishing system. The smart kitchen has the capability of significantly improving one's lifestyle. Another study proposed the implementation of an interactive kitchen monitoring system and an automation system in the kitchen. The trend is to build smart kitchen systems using the hardware system framework of a future home smart kitchen, terminal, kitchen central processor, and service robot. Our project aims to create a new smart kitchen that can be controlled remotely. Another system controls and operates the entire grocery system. Similarly, the smart HAC system for the smart kitchen presents a similar type of idea and uses similar methodologies and automation sensors. The kitchen is one of the most important rooms in a smart home, and can include a smart boiler, smart refrigerator, gas stove, and smart table.

Another author presented a system idea based on the development of an IoT prototype for controlling the AC

Appliances in the kitchen. To access a smart kitchen, created a Web platform for smart kitchens. The created Web platform includes a user interface through which the user can inspect the monitored sensors and control the smart kitchen appliances. In . The author mounted a camera permanently in the smart kitchen cabinet to monitor and control the smart kitchen appliances. A Decision Tree-based approach was used in for the Human Health Index and to monitor the kitchen effectively. A Deep Safe system was proposed by an author using the Internet of Things-based Hybrid Kitchen

Safety Protecting System with Stove Fire Recognition in . Researchers have undertaken work to make human life easier and more efficient by automating tasks. In this regard, our proposed home automation system based on IoT was designed and employed in the kitchen to automate and monitor smart kitchen appliances.

IV. METHODOLOGY

In this section, the proposed methodology for monitoring and automating the smart kitchen is discussed. Because automation has not yet made its way into most kitchens, particularly in Pakistan, our primary goal was to design a smart kitchen automation system based on an Arduino board connected to the Internet, and which is capable of being operated remotely from any Android smartphone. The ultimate goal is to make it possible for any smartphone running the Android operating system to control devices from a distance. Figure 1 illustrates the proposed solution

With the use of smartphones, a remote controlled home automation system yields the most modern solution. To accomplish this, the Arduino board placed at the receiver end communicates with the Internet, while a GUI program on the mobile phone running on the transmitter end delivers on/off orders to the receiver where the loads are connected, and vice versa. Through the use of this technology, the loads can be turned on and off remotely by simply tapping the designated location on the GUI. The Arduino board manages the loads by controlling them with relays

Fig 1: Proposed automation and monitoring system.

V. HARDWARE

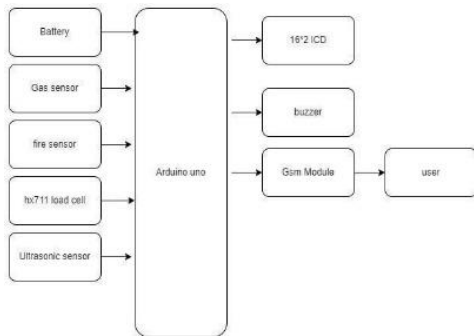

a) BUZZER



Fig 2 : Buzzer

A **buzzer** is a small yet efficient component to add sound features to our project/system. It is very small and compact 2-pin structure hence can be easily used on [breadboard](#), Perf Board and even on PCBs which makes this a widely used component in most electronic applications.

There are two types of buzzers that are commonly available. The one shown here is a simple buzzer which when powered will make a Continuous Beep... sound, the other type is called a readymade buzzer which will look bulkier than this and will

Beep. Beep. Beep. Sound due to the internal oscillating circuit present inside it. But, the one shown here is most widely

used because it can be customised with help of other circuits to fit easily in our application.

This buzzer can be used by simply powering it using a DC power supply ranging from 4V to 9V. A simple 9V battery can also be used, but it is recommended to use a regulated +5V or +6V DC supply. The buzzer is normally associated with a switching circuit to turn ON or turn OFF the buzzer at required time and require interval.

Pin Number	Pin Name	Description
1	Positive	Identified by (+) symbol or longer terminal lead. Can be powered by 6V DC
2	Negative	Identified by short terminal lead. Typically connected to the ground of the circuit

Table 1: Pin configuration

b) ULTRASONIC SENSOR



Fig 3: Ultrasonic Sensor

As shown above the **HC-SR04 Ultrasonic (US) sensor** is a 4 pin module, whose pin names are Vcc, Trigger, Echo and Ground respectively. This sensor is a very popular sensor used in many applications where measuring distance or sensing objects are required. The module has two eyes like projects in the front which forms the Ultrasonic transmitter and Receiver. The sensor works with the simple high school formula that respectively.. $z\text{zistance} = \text{Speed} \times \text{Time}$ The Ultrasonic transmitter transmits an ultrasonic wave, this wave travels in air and when it gets objected by any material it gets reflected back,

HC-SR04 distance sensor is commonly used with both micro controller and microprocessor platforms like Arduino, ARM, PIC, Raspberry Pie etc. The following guide is universally since it has to be followed irrespective of the type of computational device used.

Power the Sensor using a regulated +5V through the Vcc and Ground pins of the sensor. The current consumed by the sensor is less than 15mA and hence can be directly powered by the on board 5V pins (If available). The Trigger and the Echo pins are both I/O pins and hence they can be connected to I/O pins of the microcontroller. To start the measurement, the trigger pin has to be made high for 10µs and then turned off. This action will trigger an ultrasonic wave at frequency of 40kHz from the transmitter and the receiver will wait for the wave to return. Once the wave is returned after it getting reflected by any object the Echo pin goes high for a particular amount of time which will be equal to the time taken for the wave to return back to the sensor

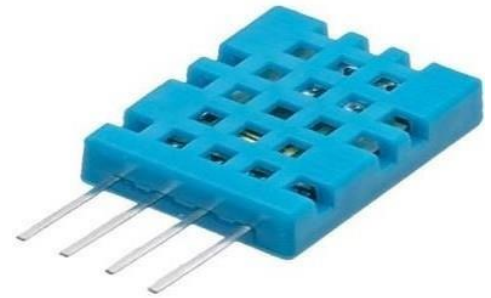

Fig 6 : Temperature and Humidity Sensor

c) GAS SENSOR



Fig 4 : Gas Sensor

A Gas sensor serves to detect and measure the concentration of gas in the environment. Nowadays you can find many different types of easy to use gas sensors, especially in MQ series. In this article, I'm covering the MQ-135 gas sensor which is in fact a very popular and inexpensive air quality sensor. With the increasing air and environmental pollution, monitoring air quality is getting more and more important. Did you know? Even a small raise in the concentration of carbon dioxide can cause increased fatigue, headaches or nausea. The MQ135 air quality sensor will be a good assistant here as it can provide useful information about the surrounding air. The MQ-135 gas sensor is available as a prewired module or as just the gas sensor part alone. If you're trying to detect the presence of a gas (not measuring PPM) only then you can buy a cheap module since it comes with onboard electronics to provide a digital output signal

d) FIRE SENSOR

A Flame Sensor module or Fire Sensor module is a small size electronics device that can detect a fire source or any other bright light sources. This sensor basically detects IR (Infrared) light wavelength between 760 nm – 1100 nm that is emitted from the fire flame or light source. The flame sensor comes with a YG1006 Phototransistor sensor which is a high speed and high sensitivity. Two types of IR Infrared Flame Sensor Module available in the market one having three pins (D0, Gnd, Vcc) and another one having four pins (A0, D0, Gnd, Vcc) both are can be easily used with Arduino and other microcontroller boards.

Fig 5: Fire Sensor

e) TEMPERATURE AND HUMIDITY SENSOR

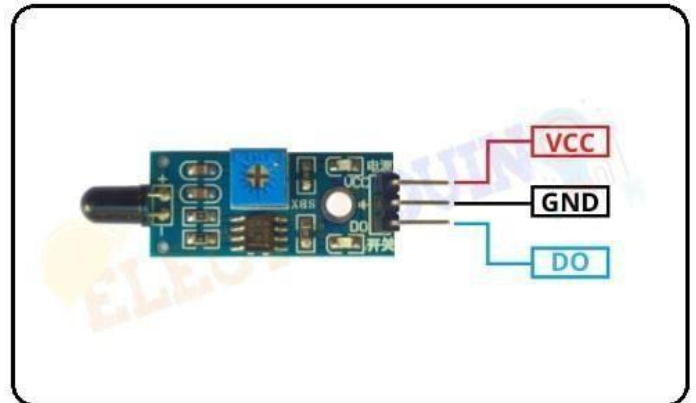

DHT11 is a low-cost digital sensor for sensing temperature and humidity. This sensor can be easily interfaced with any microcontroller such as Arduino, Raspberry Pi etc... to measure humidity and temperature instantaneously.

DHT11 humidity and temperature sensor is available as a sensor and as a module. The difference between this sensor and module is the pull-up resistor and a power-on LED. DHT11 is a relative humidity sensor. To measure the surrounding air this sensor uses thermistor and a capacitive humidity sensor.

DHT11 sensor consists of a capacitive humidity sensing element and a thermistor for sensing temperature. The humidity sensing capacitor has two electrodes with a moisture holding substrate as a dielectric between them. Change in the capacitance value occurs with the change in humidity levels. The IC measure, process this changed resistance values and change them into digital form

f) Hx711 LOAD CELL



Fig : 7 Load cell

A load cell is a sensor that measures the force applied to it along a specific direction and converts it to an electrical signal that can be converted to an equivalent force value. There are many types of load cells, in this post we will focus on a Bar-Type Strain Gauge Load Cells. For the load cell shown on the image, you fix one end (via screws) to a fixed object. The other end will be where the force is applied (normally attached to something). Think of this for the example of a small scale.

One end attached to the base of the scale, and the other end attached to the plate where you place things whose weight you want to measure.

g) ARDUINO

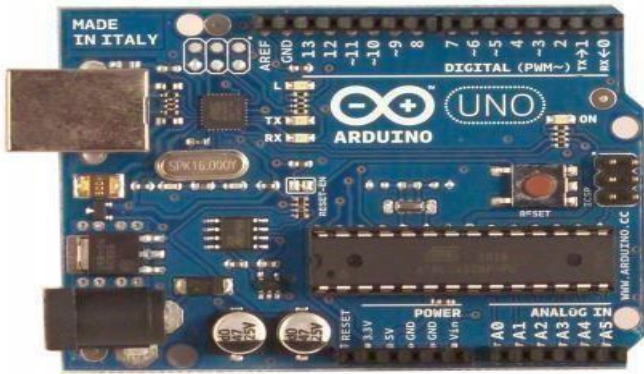

Fig : 8 Arduino Board

The Arduino Uno is a microcontroller board based on the ATmega328 (datasheet). It has 14 digital input/output pins (of which 6 can be used as PWM outputs), 6 analog inputs, a 16 MHz crystal oscillator, a USB connection, a power jack, an ICSP header, and a reset button. It contains everything needed to support the microcontroller; simply connect it to a computer with a USB cable or power it with a AC-to-DC adapter or battery to get started. The Uno differs from all preceding boards in that it does not use the FTDI USB-to-serial driver chip

"Uno" means one in Italian and is named to mark the upcoming release of Arduino

The Uno and version 1.0 will be the reference versions of Arduino, moving forward. The Uno is the latest in a series of USB Arduino boards, and the reference model for the Arduino platform

VI . SOFTWARE

a) ARDUINO SOFTWARE

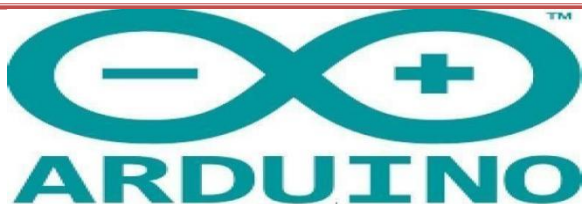

Fig 9 : Arduino Software

There are numerous different microcontrollers and

ler platforms accessible for physical computing. Parallax Basic Stamp, Net media's BX-24, Phidgets, MIT's Handy board, and numerous others offer comparative usefulness. These apparatuses take the chaotic subtle elements of microcontroller programming and wrap it up in a simple to-utilize bundle. Arduino additionally rearranges the methodology of working with microcontrollers; moreover it offers some advantages for instructors, students, and intrigued individuals:

Inexpensive - Arduino boards are moderately cheap compared with other microcontroller boards. The cheapest version of the Arduino module can be amassed by hand, and even the preassembled Arduino modules cost short of what \$50.

Cross-platform - The Arduino programming runs multiple operating systems Windows, Macintosh OSX, and Linux working frameworks. So we conclude that Arduino has an advantage as most microcontroller frameworks are constrained to Windows.

Straightforward, clear programming method - The Arduino programming environment is easy to use for novices, yet sufficiently versatile for cutting edge customers to adventure as well. For educators, its favorably engaged around the Processing programming environment, so with the nature of arduino.

Open source and extensible programming. The Arduino program language is available as open source, available for development by experienced engineers

b) ARDUINO INITIAL SETUP

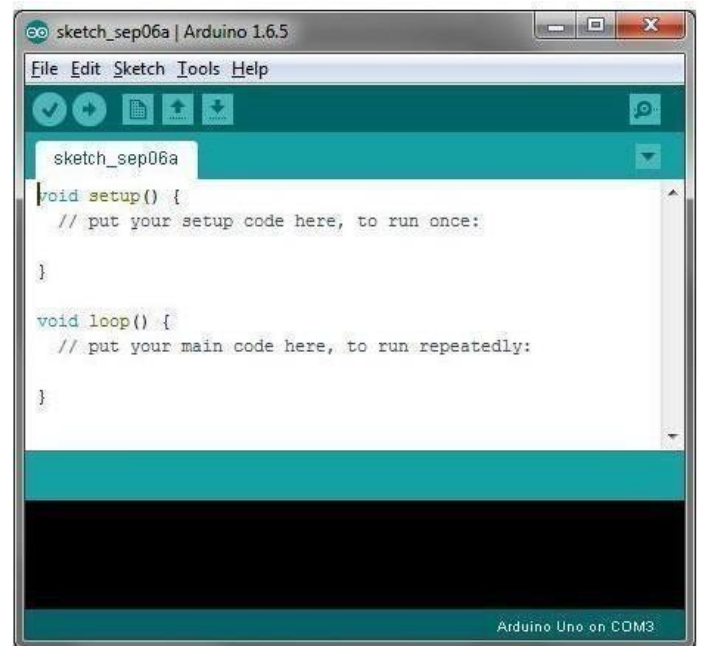

Arduino IDE Default Window

This is the Arduino IDE once it's been opened. It opens into a blank sketch where you can start programming immediately. First, we should configure the board and port settings to allow us to upload code. Connect your Arduino board to the PC via the USB cable.

c) IDE: BOARD SETUP

You have to tell the Arduino IDE what board you are uploading to. Select the Tools pulldown menu and go to Board. This list is populated by default with the currently available Arduino Boards that are developed by Arduino. If you are using an Uno or an Uno-

Compatible Clone (ex. Funduino, Sain Smart, IEIK, etc.), select Arduino Uno. If you are using another board/clone, select that board.

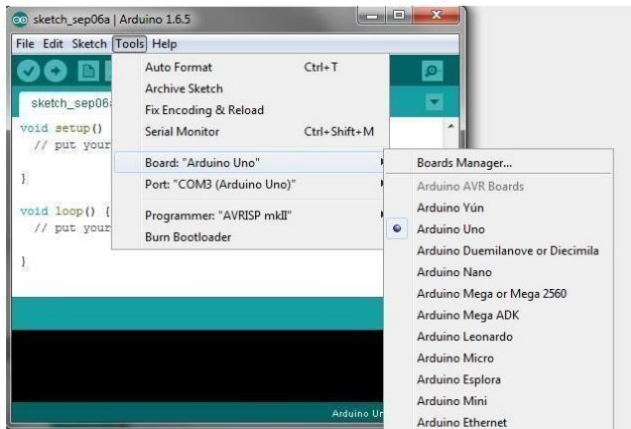

Arduino IDE: Board Setup Procedure

d) IDE:COM PORT SETUP

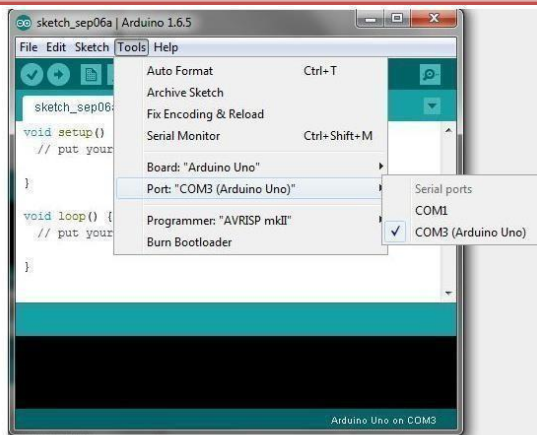

Arduino IDE: COM Port Setup

If you downloaded the Arduino IDE before plugging in your Arduino board, when you plugged in the board, the USB drivers should have installed automatically. The most recent Arduino IDE should recognize connected boards and label them with which COM port they are using. Select the Tools pulldown menu and then Port. Here it should list all open COM ports, and if there is a recognized Arduino Board, it will also give its name. Select the Arduino board that you have connected to the PC. If the setup was successful, in the bottom right of the Arduino IDE, you should see the board type and COM number of the board you plan to program. Note: the Arduino Uno occupies the next available COM port; it will not always be COM3.

e) TESTING

Uploading Blink One common procedure to test whether the board you are using is properly set up is to upload the “Blink” sketch. This sketch is included with all Arduino IDE releases and can be accessed by the File pull-down menu and going to Examples, 01.Basics, and then select Blink. Standard Arduino Boards include a surface-mounted LED labeled “L” or “LED” next to the “RX”

and “TX” LEDs, that is connected to digital pin 13. This sketch will blink the LED at a regular interval, and is an easy way to confirm if your board is set up properly and you were successful in uploading code. Open the “Blink” sketch and press the “Upload” button in the upper-left corner to upload “Blink” to the board.

Upload Button: 

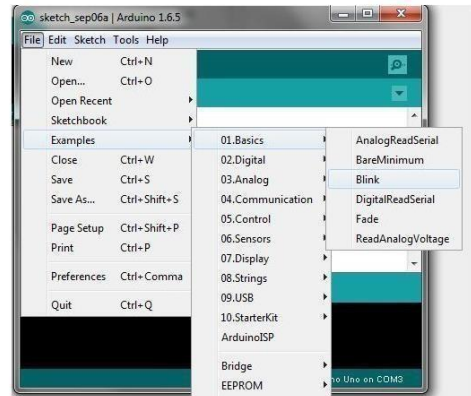

Arduino IDE: Loading Blink Sketch

VII. RESULT

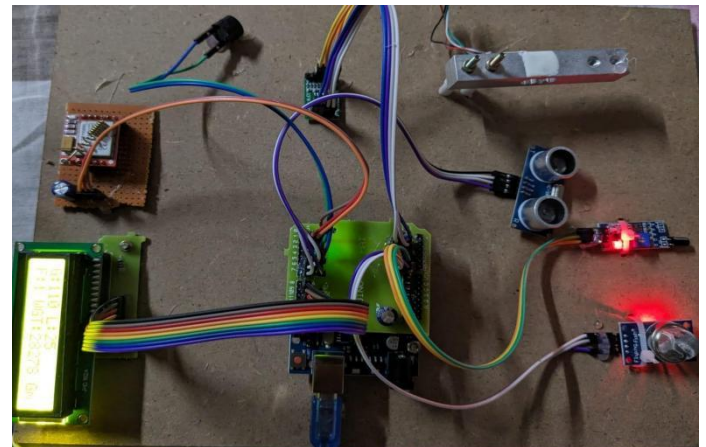

Fig10 : Circuit Board



Fig : Output Result

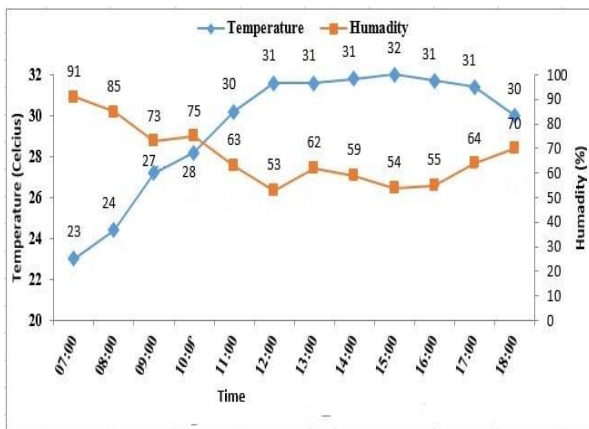

Fig 11 : Graph of Temperature and Humidity against time

The result displays 1 when fire exists otherwise it displays as 0.

The test results show that the system can work properly. Each sensor can work correctly. All data sent by the sensor can be accepted by Arduino to determine an action for the output device. Output devices such as alarm, and indicator lights can work according to their function. The data that received by Arduino is also sent to the Cayenne server via Wi-Fi. Data received by the Cayenne instantly displayed on the dashboard. Data displayed on the dashboard can be seen in figure .

VIII. CONCLUSION

By integrating sensors with Arduino and GSM technology, this project aims to enhance kitchen safety and convenience. The system's ability to detect gas leakage, monitor gas weight, and detect fires, combined with its alert capabilities, can help prevent accidents and save lives. The project demonstrates the potential of smart home solutions in improving safety and convenience in everyday life.

This paper presents a smart kitchen with automation and monitoring system project that is currently in development. The technology enables the user to control their home appliances from their mobile phone, which is a desirable function. Users are able to turn on and off their air conditioning and other domestic equipment such as refrigerators, gas stoves, freezers, and ovens, and manage the gas level in their homes. An Internet of Things (IoT)-based smart kitchen with an automation and monitoring system is the focus of this project. The ultimate goal is to make it feasible for any smartphone running the Android operating system to operate devices from a distance using the Android remote control application. With this technology, the user can control the amount of gas that is released into the home directly from their smartphone. Furthermore, a simulation was performed in Matlab2016b; the cost achieved for unscheduled houses was USD 33.32, and that for two, four, and six houses was USD 23.64, 22.32, and 19.54, respectively, indicating that cost and power are directly proportional. The results show that the proposed solution is more cost effective than unscheduled houses. The results showed that using this system has a

scientifically significant effect on electricity usage and cost. In the future, we will integrate machine learning techniques to further optimize this system and provide the predicted pattern to the user for operating their home devices

IX. REFERENCES

- [1] Gusmeroli S, Haller S, Harrison M, Kalaboukas K, Tomasella M, Vermesan O, Vogt H, Wouters K. Vision and challenges for realising the internet of things.
- [2] Dohr A, Modre-Oprian R, Drobnic M, Hayn D, Schreier G. The internet of things for ambient assisted living. In Information Technology: New Generations (ITNG), 2010 Seventh International Conference on 2010 Apr 12 (pp. 804-809). IEEE.
- [3] Eisenhauer M, Rosengren P, Antolin P. A development platform for integrating wireless devices and sensors into ambient intelligence systems. In Sensor, Mesh and Ad Hoc Communications and Networks Workshops, 2009. SECON Workshops' 09. 6th Annual IEEE Communications Society Conference on 2009 Jun 22 (pp. 1-3). IEEE.
- [4] Amaxilatis D, Georgitzikis V. Using Codebender and Arduino in Science and Education. In System-Level Design Methodologies for Telecommunication 2014 (pp. 119-134). Springer, Cham.
- [5] David N, Chima A, Ugochukwu A, Obinna E. Design of a home automation system using arduino. International Journal of Scientific & Engineering Research. 2015 Jun;6(6):795-801.
- [6] Simić M, Stojanović GM, Manjakkal L, Zaraska K. Multi-sensor system for remote environmental (air and water) quality monitoring. In Telecommunications Forum (TELFOR), 2016 24th 2016 Nov 22 (pp. 1-4). IEEE
- [7] Li, J.; Lin, Y. IoT Home Automation—Smart homes and Internet of Things. In Proceedings of the 3rd International Academic Exchange Conference on Science and Technology Innovation (IAECST), Guangzhou, China, 10–12 December 2021; pp. 294–298.
- [8] David, N.; Chima, A.; Ugochukwu, A.; Obinna, E. Design of a home automation system using Arduino. Int. J. Sci. Eng. Res. 2015, 6, 795–801.
- [9] Ahmed, M.M.; Qays, M.O.; Abu-Siada, A.; Muyeen, S.M.; Hossain, M.L. Cost-Effective Design of IoT-Based Smart Household Distribution System. Designs 2021, 5, 55. [CrossRef]
- [10] Sharif, Z. Internet-of-Things based Home Automation System using Smart Phone. Sir Syed Univ. Res. J. Eng. Technol. 2021, 11, 1–9. [CrossRef]
- [11] Wang, J.; Zhang, Y.C. A Review on Internet of Things Based Smart Home. In Proceedings of the 2021 International Conference on Culture-Oriented Science & Technology (ICCST), Beijing, China, 18–21 November 2021; pp. 273–277.
- [12] Akkasaligar, P.T.; Biradar, S.; Pujari, R. Internet of Things Based Smart Secure Home System. In International Conference on Intelligent Data Communication Technologies and Internet of Things; Springer: Cham, Switzerland, 2019; pp. 348–355.

- [13] Garg, S.; Chatterjee, J.M.; Le, D.N. Implementation of Rest Architecture-Based Energy-Efficient Home Automation System. Secur. Des. Cloud Iot Soc. Netw. 2019, 1, 143–152.
- [14] Balaji, A.; Sathyasri, B.; Vanaja, S.; Manasa, M.N.; Malavega, M.; Maheswari, S. Smart Kitchen Wardrobe System Based on IoT. In Proceedings of the 2020 International Conference on Smart Electronics and Communication (ICOSEC), Trichy, India, 10–12 September 2020; pp. 865–871.
- [15] Desai, H.; Guruvayurappan, D.; Merchant, M.; Somaiya, S.; Mundra, H. IoT Based Grocery Monitoring System. In Proceedings of the 2017 Fourteenth International Conference on Wireless and Optical Communications Networks (WOCN), Mumbai, India, 24–26 February 2017; pp. 1–4.
- [16] Pendbhajh, A.; Rajesh, S. IOT in Home Grocery Management. In Proceedings of the Somaiya International Conference on Technology and Information Management, Mumbai, India, 25–26 February 2017; pp. 44–49.
- [17] Salah Uddin, M.; Khan, M.; Ali, D. Kitchen grocery items monitoring system based on internet of things. Int. J. Comput. Netw. Technol. 2019, 7, 47–52. [CrossRef]
- [18] Suganya Devi, K.; Sabarish, N.S.; Sankra, M.; Santhosh Kumar, A. Internet of Things (IoT) based smart kitchen pantry. Ir. Interdisc. J. Sci. Res. 2020, 4, 56–61.
- [19] Sah, D.K.; Poongodi, M.; Donta, P.K.; Hamdi, M.; Cengiz, K.; Kamruzzaman, M.M.; Rauf, H.T. Secured Wireless Energy Transfer for the Internet of Everything in Ambient Intelligent Environments. IEEE Internet of Things Magazine 2022, 5, 62–66. [CrossRef]
- [20] Jian-Mei, S.; Li-Juan, W.; Xi, Y.; Jun-Shan, Y. Design and implementation of intelligent kitchen system based on internet of things. In Proceedings of the 2018 International Conference on Smart Grid and Electrical Automation (ICSGEA), Changsha, China, 9–10 June 2018; pp. 253–256.
- [21] Pudugosula, H. Automatic smart and safety monitoring system for kitchen using Internet of Things. In Proceedings of the 2019 International Conference on Intelligent Computing and Control Systems (ICCS), Madurai, India, 15–17 May 2019; pp. 1174–1177.
- [22] Anandhakrishnan, S.; Nair, D.; Rakesh, K.; Sampath, K.; Nair, G.S. IOT Based Smart Gas Monitoring System. IOSR J. Electr. Electron. Eng. (IOSR-JEEE) 2017, 2017, 82–87.
- [23] Abdullah, N.F.; Abdullah, N.S. Kitchen Gas Leakage Control System. Res. Innov. Tech. Vocat. Educ. Train. 2021, 1, 187–193.
18. Shrestha, S.; Anne, V.K.; Chaitanya, R. IoT based smart gas management system. In Proceedings of the 3rd International Conference on Trends in Electronics and Informatics (ICOEI), Tirunelveli, India, 23–25 April 2019; pp. 550–555.

AUTHORS PROFILE



Ms. Yanala Bhavana is a student currently pursuing B. Tech in the stream of ECE in Tirumala Engineering College, Jawaharlal Technological University-Kakinada. She is a member of IETE.



Mr. Toluchuri Vinod Kumar is a student currently pursuing B. Tech in the stream of ECE in Tirumala Engineering College, Jawaharlal Technological University-Kakinada. She is a member of IETE.



Ms. Sayyad Khashira is a student currently pursuing B. Tech in the stream of ECE in Tirumala Engineering College, Jawaharlal Technological University-Kakinada. She is a member of IETE.



Ms. Pilli Sushma is a student currently pursuing B. Tech in the stream of ECE in Tirumala Engineering College, Jawaharlal Technological University-Kakinada. She is a member of IETE.

Under the Guidance of Prof Mr. G. Mallikarjuna Rao
M.Tech