

Internet of Things Based Electricity Theft Detection

Mrs. B. Eswaramma¹, M. Suma², N. Alekhya³, M. Pavan Kalyan⁴,

P. SaiRam⁵

¹Asst.prof, Department of Electronics and Communication Engineering, Tirumala Engineering College, India; eswari.bitra5@gmail.com

²UG, Department of Electronics and Communication Engineering, Tirumala Engineering College, India; suma.mukkanti1@gmail.com.

³UG, Department of Electronics and Communication Engineering, Tirumala Engineering College, India; alekhya.nallamothe27@gmail.com

⁴UG, Department of Electronics and Communication Engineering, Tirumala Engineering College, India ; kalyanmamillapalli1369@gmail.com.

⁵UG, Department of Electronics and Communication Engineering, Tirumala Engineering College, India; pryadav.sai@gmail.com

Abstract:

Electricity theft can be defined as an illegal usage of electricity equipment or service with the intention to avoid billing charges. Theft of electricity results in loss of revenue to the utility / institution. In this area of electricity consumers is divided into sections and for each section IoT based Energy meter is installed to monitor all the parameter of the sections. And one master unit is provided at near distribution pole site to monitor all the sections data.

Keywords: Internet of things, detection, electricity theft.

1. Introduction

Theft of electricity is the criminal practice of stealing electrical power. According to a study the world loses US\$89.3 billion annually to electricity theft. The highest losses were in India (\$16.2 billion), followed by Brazil (\$10.5 billion) and Russia (\$5.1 billion). Nationally, total transmission and distribution losses approach 23% and some states' losses exceed 50%. A huge amount of power is required for the Integrated steel plants To meet this requirement it is calculated that approximately a capacity of 25,000 MW power plant needs to be installed apart from the captive power & blowing stations . By the help of our prototype we can detect the theft and possibly save the maximum electricity which can be effectively used in the steel plants.

2. Proposed Methodology

The architecture and working of the proposed system is explained in this section. It also describes the meter setup and the hardware components used in this research.

2.1 Hardware module

In the proposed system the power utility maintains a server and each consumer are provided a meter. Local network and IOT ESP8266 module are used by the server and the meter to communicate with each other. Fig. 1 shows an overview of the proposed power theft detection system. The electricity meter consists of a microcontroller (ATmega 328), current sensor, LCD display, relay, keypad and IOT ESP8266. In this the current sensing sensor sense the amount of current receives to the meter in the form of power as power directly proportional to the current. The predefined data is stored in Electrical erasable read only memory (EEPROM) of AT89C52 microcontroller which allows to store data that and can be erasable and reprogrammable so the data which is stored in the memory is remain present till the data will be overwrite. When the supply is given after removing the supply it will take the previous set value which is set by the supplier. The reading of meter is displayed on LCD. Relay is used as a switch. The meter reading is transfer to the webpage of electricity board section using Node MUC IOT ESP8266. If amount of power used by meter is beyond the limit then the notification regarding theft is displayed on the webpage of electricity board section. This system allows the supplier to disconnect the connection from a distant server in case the sector utilizing high power. This method eliminates the need of human power during disconnection and reconnection of the load.

Another major advantage of this method is that it will provide security that the whole system is accessible by the authorized person. The local host html webpage is created by the Electricity board section which is based on the given condition it shows the consumption of power in a given sector in units form as well as showing the power is in limit or beyond the limit by using IOT ESP8266 Wi-Fi module which sends the information wirelessly.

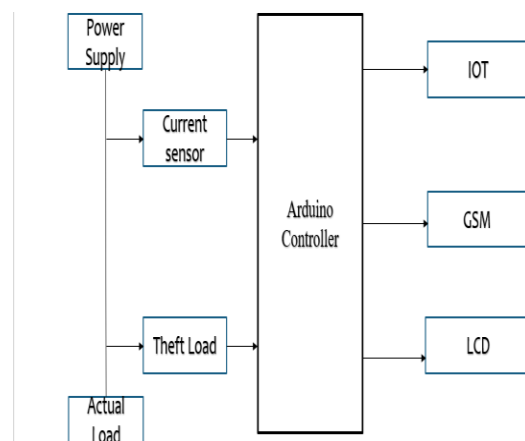

Figure 1: Proposed Block Process Flow

The process flow has clearly defining the actual design steps of detection of theft. Here, once the device is power ON all components will initialized. The system will check the connectivity interface is in proper working condition. If the connectivity interface is working properly, the system constantly check if the power theft in meter occurred or not and the meter reading will displayed on the webpage.

As the power theft occurred, the sensor will send a signal to the processor which in turn triggers the connectivity interface to send message to the web that meter has been using high amount of power. The notification is displayed on webpage if the high amount of power consumes then the supplier disconnect the load from the distribution network of the particular sector.

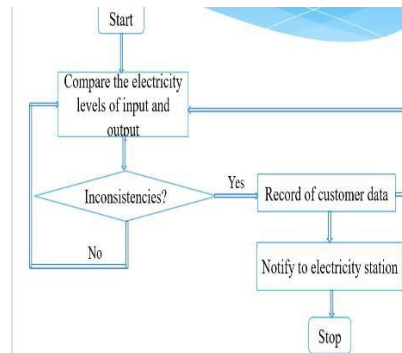

Figure 2: Process Flow

i. 2.2 Hardware Setup

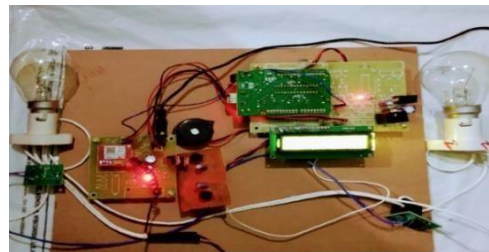

Figure 3: Developed experimental Setup

In this the current sensor output pins are connected to the loads. The LCD source VDD pin and VSS pin are connected to the source and ground pin of ATmega328. For displaying the data the D0-D7 pins of LCD are connected to same pin of the microcontroller. The meter status is checked using Proteus software by in different conditions. In this on increasing the load power increases.

2.3 Message Display of Electricity Theft

The Message Display of Electricity Theft shown in Fig.4. In this initially we are registering the number in project through GSM. Whenever, the theft is detected the



message will be sent to the respective registered number.

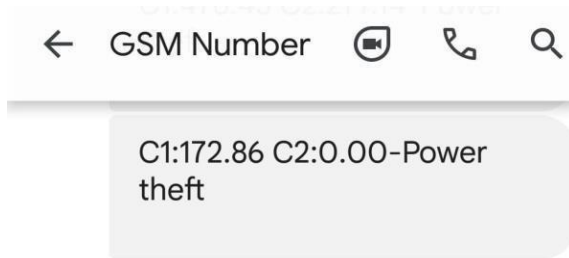

Figure 4: Message Display of Power Theft

Result

The live readings of the meter are displayed in the webpage created by the electricity board section along with the power consumption of the meter and the status of the meter are displayed on the LCD as shown in fig.4. If power theft occurs, then the notification regarding power theft is displayed on the webpage as well as on the LCD as shown in fig.5. This system now cannot be reset by the consumer i.e. it now needs a person from the authorized agency to reset the whole of the system.



Figure 5. LCD Display at normal condition



Figure 6. LCD Display at Electricity Theft Condition

This wireless IOT based technique is much useful to detect the stealing of electricity worldwide. To control the revenue losses, the authorized officials need to detect the theft of electricity. It means the theft of power beyond the limit is the most effective one

over the whole world comparing to the other techniques used to steal the electricity i.e. the unauthorized consumption of the electricity. It provide safety as the limit of the transformer will change by the authorized person of electricity board section along with the supply cut by this system can only be reset by them therefore this system helps to reduce the manual error and provide an excellent way to detect the bypassing of the energy meter.

Hence further more and more improvements will be done to make the system much more efficient and excellent also for the long haul. The analysis between consumption of power is performed using Lab view.

References

- [1] R. Jiang, H. Tagaris, A. Lachsz, and M. Jeffrey, "Wavelet based feature extraction and multiple classifiers for Electricity fraud detection", in Proc. IEEE Power Eng. Soc. Transmission and Distribution Conf. Exhibit. Asia Pacific, vol. 3, (2002) pp. 2251–2256.
- [2] A Rubino, "Energy Transmission and Distribution Power theft in India," , NatureEnergy Policy 93 , 127– 136 Articlenunder: 16044, (2016).
- [3] C.R.Paul,," System loss in a metropolitan utility network", Power Eng. J., vol. 1, no. 5, (1987) ,pp. 305– 307.
- [4] N.Tobinand N.Sheil,," Managing to Reduce Power Transmission System Losses, in Transmission Performance.Dublin",Ireland: Publ. Electricity Supply BoardInt.(1987).
- [5] R. L. Sellick and C. T. Gaunt, "Load Data Preparation for Losses estimation", in Proc.7th Southern African Universities Power Engineering Conf. , Stellenbosch, South Africa, vol. 7, (1998), pp. 117–120.
- [6] I. E. Davidson, A. Odubiyi, M. O. Kachienga, and B. Manhire, "Technical loss computation and economic dispatch model in T&D systems in a deregulated ESI", Power Eng. J., vol. 16, no. 2, (2002),pp. 55–60.
- [7] Dimitrios Georgakopoulos, Prem Prakash Jayaraman ,," Internet of things: from internet scale sensing to smart services", in Springer- Verlag Wien, ISSN: 0010-485X (2016).
- [8] Jawad Nagi, Keem Siah Yap, Sieh Kiong Tiong, Syed Khaleel Ahmed and Malik Mohamad, "Nontechnical Loss Detection for Metered Customers in Power Utility Using Support Vector Machines", IEEE Transactions on power delivery, VOL. 25, NO. 2, Print ISSN: 0885-8977, Electronic ISSN: 1937-4208, (2010).
- [9] U.Grasselli, A. Prudenzi, "Utilization of a PLC in power system protection applications", IEEE Applications of Industrial Electronics Systems, (1990). Raksha Kala, "Energy Conservation and Monitoring System for Smart City using Internet of Things", SSRG International Journal of Computer Science and Engineering (SSRG-IJCSE), volume 3 Issue 8, (2016).
- [10] G. L. Prashanthi, K. V. Prasad, "Wireless power meter monitoring with power theft detection and intimation system using GSM and Zigbee networks", IOSR Journal of Electronics and Communication Engineering (IOSR-JECE) e-ISSN: 2278-2834,p- ISSN: 2278-8735.Volume 9, Issue 6, (2014), PP 04- 08.
- [11] Chun-Hao Lo and Nirwan Ansari, "CONSUMER: A novel hybrid intrusion detection system for distribution networks in Smart Grid", IEEE Transactions on Emerging Topics in Computing Volume: 1, Issue: 1, Electronic ISSN: 2168-6750, (2013).
- [12] Karthikeya S, Bhuvanewari P.T.V,"IoT Based Real-Time Residential Energy Meter Monitoring System",IEEE Trends in Industrial Measurement and Automation (TIMA),Electronic ISBN: 978-1-5090- 3001-9 ISBN: 978-1-5090-3002-6, (2017).

[13] Harsha Khandel , Suchitra Pandey and

D. Reynolds, "A Review on IOT Based Power Theft Detection and Control Systems", International Journal of Innovative Research in Electrical, Electronics, Instrumentation and Control Engineering, Vol. 5, Issue 9, ISSN (Online) 2321 – 2004 ISSN (Print) 2321 –5526 , **(2017)**.

[14] Nabil Mohammad, Anomadarshi Barua and Muhammad Abdullah Arafat, "A Smart Prepaid Energy Metering System to Control Electricity Theft",IEEE International Conference on Power, Energy and Control (ICPEC),Electronic ISBN: 978-1-4673-6030-2 Print ISBN: 978-1-4673-6027-2, **(2013)**.

[15] Chun-Hao Lo and Nirwan Ansari, "CONSUMER: A novel hybrid intrusion detection system for distribution networks in Smart Grid", IEEE Transactions on Emerging Topics in Computing Volume: 1, Issue: 1, Electronic ISSN: 2168-6750, **(2013)**