

DESIGN AND ANNALYSIS OF COMBI-SWITCH BRACKET

SushilRamdasDeore¹, Kailas Subhash Jagtap²,

Alkesh Suresh Chandak³, Prof. BhaskarVithoba Varade⁴

^{1,2,3,4}Department of Mechanical Engineering, G.E.S.R.H.S. College of Engg. Nashik (India)

ABSTRACT

Design Combi- switch design bracket die, and analyses in Hyper mesh software. Also find out the stresses developed. Reduce the cost of the progressive dies without compromising on the quality of output. Also find the stresses produces in die. These stresses are compared to yield stress and considering minimum factor of safety 2.0, the thickness of frame of the progressive dies selected to reduce the volume of material utilized for building the structure and hence to reduce the cost of the machine.

Keyword: Bend, Blank Tool, Bracket, Piercing Tapping, Progressive Tool.

I. INTRODUCTION

Now a day's a very large variety of sheet metal forming processes are used in modern sheet metal product manufacturing company. Many of these sheet metal forming processes are used in making the parts of aircraft, automobile, ship, and other products, by using complex equipment derived from the latest discoveries. With the ever increasing knowledge of science and technology, future deformation processes promise to be even more intricate to meet the need for high productivity, cheap price, and greater accuracy. However, for the unique advantages, the more sophisticated deformation processes of today have not replaced the need for basic sheet metal forming processes and dies.

Sheet metal stamping dies are used for both serial and mass production. Their characteristics are: high productivity, optimal material usage, easy servicing of machines, not required skilled operator, and economic advantage. Parts made from sheet metal have many attractive qualities: good accuracy of dimension, ample strength, light weight, and a broad range size is possible to manufacture.

Design of sheet metal dies is a large division of tool engineering, used in varying degree in manufacturing industries like automobile, electronic, house hold wares and in furniture. There is no doubt that accuracy achieved by the new ideas in design and construction applied by the press tool designer, coupled latest development made in related fields made more productive, durable and economical[1].

1.1 Types of sheet metal works

- a. Punching: Punching is the sheet metal forming process that uses a punch press to force a tool.
- b. Embossing: Embossing is the operation used in making raised figures on sheet with its corresponding relief on the other side.

c. Blanking: It is a process in which the punch removes a portion of metal from the stock of sheet metal of the necessary thickness & width.

Design of sheet metal dies is a large division of tool engineering, used in varying degree in manufacturing industries like automobile, electronic, house hold wares and in furniture. There is no doubt that accuracy achieved by the new ideas in design and construction applied by the press tool designer, coupled latest development made in related fields made more productive, durable and economical. [2]\

1.2 Problem Statement

It is a bracket used for holding steering. Design and analysis of die for model bracket shown in fig 1.1.

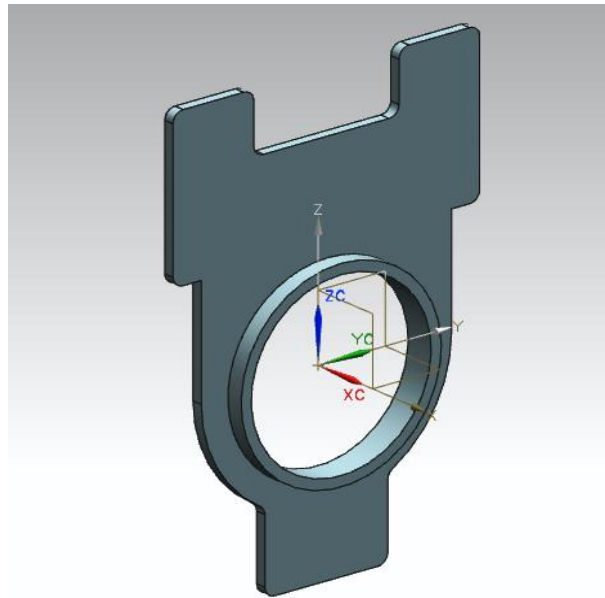

Fig. 1.1 model bracket

Operations require for the product:

- 1. Punching
- 2. Embossing,
- 3. Blanking,

II. DESIGN OF PROGRESSIVE DIE COMPONENTS

The standard allowance (die clearance) between the punch and die cutting edges depend upon the properties of the material to be sheared. Ductile materials should have lesser die clearance otherwise the soft metal will be drawn in to the gap. On the other hand, the harder materials need large die clearance for good shearing action. Excessive die clearance causes more burrs on the sheared component. Reduction in die clearance reduces the burr, but it accelerates the blunting of the cutting edges of dies and punches. Die clearance for shearing of mild steel sheet is recommended 2.5% to 5.0% of its thickness.

$$\text{Minimum recommended die clearance} = \frac{2.5}{100} \times 2.5 = 0.0625mm$$

$$\text{Maximum recommended die clearance} = \frac{5}{100} \times 2.5 = 0.125mm$$

Increase in die clearance increase tool life, doubling clearances from 2.5% to 5% (for mild steel sheet) doubles the tool life. So when the requirements of blanks dimensional accuracy are not very high, it is convenient to keep die clearance more and remove the excessive tensile burr on the blanks manually.[3]

2.1 Shear Force:

The force required to be exerted by the punch in order to shear out the blank from the stock can be estimated from the actual shear area and shear strength of the material using formulae.

$$F = f_s \times L_s \times t$$

Where f_s = shear strength of the blank material [N/mm²]

L_s = shear length [mm]

t = thickness of the blank material [mm][3]

[1] Shear force at punching (F_1):

$$F_1 = f_s \times L_{s1} \times t = 240 \times 240 \times 2.5 = 144000\text{N}$$

[2] Shear force at embossing (F_2):

$$F_2 = f_s \times L_{s2} \times t = 240 \times 278 \times 2.5 = 166800\text{N}$$

[3] Shear force at blanking (F_3):

$$F_3 = f_s \times L_{s3} \times t = 240 \times 395 \times 2.5 = 237000\text{N}$$

The total shear force is the sum of shear force on each station.

$$\text{Total Shearing}[F] = F_1 + F_2 + F_3 = 547800\text{N} = 55.860\text{Tonn}$$

2.2 Design of the die parts

2.2.1 Die plate

The die assembly including the stripper and all bottom elements are mounted on the bottom plate. The bottom plate gives cushioning effect to the die and provides enough space for the tool to be clamped to the press bed. There may be an opening in the base plate, which allows the blank, or slug to fall and clear off from the tool.

It is usually made from D2 tool steel material and is hardened to 60-62 HRC. It provides cutting edge. When the cutting action is over, the punch withdraws from the die but the stock strip will also move along with the punch. So for next operation, the strip cannot be moved forward. To facilitate this function one plate is fixed above the die plate. This removes the strip from the punch by the unit called stripper. A good stock guide design always allows for staggering the entryway so that the work piece will not snag; a good design also allows for the stock guide to be removable from the die without components having to be disassembled

$$T_d = \sqrt[3]{F_{sh}}$$

Where; T_d = thickness of die plate [cm]

F_{sh} = shear force [tone][3]

$$T_d = \sqrt[3]{24.16} = 2.89\text{cm} = 28.9\text{mm}$$

2.2.2 Bottom plate

The bottom plate gives cushioning effect to the die and provides enough space for the tool to be clamped to the press bed. There may be an opening in the base plate, which allows the blank, or slug to fall and clear off from

the tool. The die assembly all bottom elements are mounted on the bottom plate. The material selected for the top plate is M.S. with allowable strength= $240N/mm^2$.

$$T_b = 1.5 \times T_d = 1.5 \times 28.9 = 41.35 \text{ mm}$$

Deflection and stress calculation

Bottom plate is considered to be on parallels, the recommended deflection of the die bottom bolster (die shoe) should be less than 0.025 mm by controlling the span between the parallel blocks, or by increasing the bottom bolster thickness in the lower tool. The lower tool can be considered as a simply supported beam with a uniformly distributed load. For the system it is used seven parallel blocks to support the bottom plate.

$$\delta = \frac{5FL^3}{354EI}$$

Where, F = 80% of cutting and forming force= 0.8×547800

$$F = 438240 \text{ N}$$

L = the distance between the successive parallel block =250mm

$$E = 2.1 \times 10^5 \text{ mm}^2 [9]$$

Where, b=300mm, h= (50+40) =90mm

$$I = \frac{bh^3}{12} = 1822500 \text{ mm}^4$$

$$\delta = 0.0245 < 0.025 \text{ mm}$$

$$\sigma = \frac{F}{A} = 16.231 \text{ mm}^2$$

The stress induced $16.231N/mm^2$ which is much less than the allowable strength $240N/mm^2$. [3]

2.2.3 Top plate

The upper working member of the tool is called the top plate. The punch assembly including the punch holder and thrust plate is mounted on the top plate. The tool shank, which locates the whole tool centrally with the press ram, is also screwed into the top plate. Material chosen for the top plate is M.S. with allowable strength= $240N/mm^2$.

$$T_p = 1.25 \times T_d = 1.25 \times 28.9 = 35.125 \text{ mm}$$

$$T_p = 35.125 \text{ mm}$$

2.2.4 Punch plate

The punch is usually fitted to a plate with a light press fit. Punch holder holds all types of cutting and guiding parts to ensure alignment between punch and die made of M.S. with allowable strength= $240N/mm^2$.

$$T_{ph} = 0.65 \times T_d = 0.65 \times 28.9 = 21.7125 \text{ mm}$$

$$T_{ph} = 21.7125 \text{ mm}$$

Deflection and stress calculation for top half

It can be considered as a simply supported beam loaded at the centre and the deflection is given by;

$$\delta = \frac{FL^3}{48EI}$$

F = 80% of cutting and forming force= $0.8 \times 547800 = 438240 \text{ N}$

Where, L =240.5mm

$$E=2.1 \times 10^5 \text{ mm}^2$$

b=200mm, h= (80+30) =110mm (the width and the thickness of the top half respectively).

$$I=\frac{bh^3}{12}=22183333.333\text{mm}^4$$

$$\delta = 0.0243 < 0.025\text{mm}$$

$$\sigma = \frac{F}{A} = 19.92 \text{ mm}^2$$

The stress induced 16.231 N/mm^2 which is much less than the allowable strength $240N/mm^2$. [3]

2.2.5 Guide pillar and guide bush:

Guide pillar and guide bush are very important elements in press-tool. Pillar and bush guide the moving and fixed half of the tool in the press and they are also used to ensure accurate alignment between the punches and die. These are made of case hardened WPS. Pillar and bushes are hardened and tempered to 56-58 HRC.

Compressive strength of $330N/mm^2$.

L=185mm, D=32mm (For Guide pillar)

L=65mm, D=44mm (For Bush)[8]

2.2.6 Punch

A punch is the male member of a press tool to get a component from the strip. The shank should be running fit and the length of the shank should be 1 to 2 mm less than shank hole depth to ensure full contact of the ram face with the top bolster of the tool. The shank clamping screw should be almost at the centre of the tapered part of the shank. It is made out of good quality alloy steel called HCHCr (D2) material and hardened to 58-62 HRC. The proper length of a punch has a considerable effect on the overall performance of the die. With too long punches, the compressive stress on them may be excessive, resulting in frequent breakages. The maximum length of a punch may be calculated with the aid of Euler's formula, for punch fixed at one end and guided at the other end the critical force computed by the formula.

$$F_{cri} = \frac{2\pi^2 EI_{min}}{l^2}$$

If critical force equals punch force, then the maximum length of the punch may be calculated by the following formula,

$$l_{max} = \frac{\sqrt{2\pi^2 EI}}{\sqrt{P}}$$

$$l_{Max}=575\text{mm}$$

This is the safe maximum length that can perform without failure.[3]

Buckling for punch:

Punch material, D2 with a compressive strength of $2,200N/mm^2$. And modulus of elasticity, $E=2.1 \times 10^5 \text{ mm}^2$

Where, $L = 2l$ for one end fixed and other end free

$$L=160\text{mm}$$

For cylindrical punch 22mm diameter,

$$I = \frac{bh^3}{12} = 11499.01 \text{ mm}^4$$

$$A = \frac{\pi}{4} D^2 = 380.132 \text{ mm}^2$$

$$rg = \frac{\sqrt{I}}{\sqrt{A}} = 5.5$$

$$\text{Slenderness ratio (S.R.)} = \frac{Le}{rg} = 29.09$$

$$\text{Transition Slenderness ratio (T.S.R)} = \frac{\sqrt{2\pi^2 E}}{\sqrt{S_{yc}}} = 43.40$$

Johnson's equation will be in use to calculate the critical buckling load because the slenderness ratio is smaller than the transition slenderness ratio.

$$F_{cri} = A \left[S_{yc} - \frac{S_{yc}}{4\pi^2 E} \left(\frac{Le}{rg} \right)^2 \right]$$

$$F_{cri} = 648493.59 \text{ N} > 144000 \text{ N}$$

The applying load is less than buckling/cripling load; it is safe load.[3]

2.2.7 Emboss tool

The maximum length of a Emboss punch may be calculated with the aid of Euler's formula, for Emboss punch fixed at one end and guided at the other end the critical force computed by the formula.

$$F_{cri} = \frac{2\pi^2 EI_{min}}{l^2}$$

If critical force equals Emboss punch force, then the maximum length of the punch may be calculated by the following formula,

$$l_{max} = \frac{\sqrt{2\pi^2 EI}}{\sqrt{P}}$$

$$l_{max} = 2544 \text{ mm}$$

This is the safe maximum length that can perform without failure.

Buckling for Emboss punch

Punch material, D2 with a compressive strength of $2,200 \text{ N/mm}^2$. And modules of elasticity, $E = 2.1 \times 10^5 \text{ mm}^2$.

Where, $L = 2l$ for one end fixed and other end free

$$L = 160 \text{ mm}$$

For cylindrical punch 48mm diameter,

$$I = \frac{bh^3}{12} = 260576.2411 \text{ mm}^4$$

$$A = \frac{\pi}{4} D^2 = 1809.55 \text{ mm}^2$$

$$rg = \frac{\sqrt{I}}{\sqrt{A}} = 12$$

$$\text{Slenderness ratio (S.R.)} = \frac{Le}{rg} = 13.33$$

$$\text{Transition Slenderness ratio (T.S.R)} = \frac{\sqrt{2\pi^2 E}}{\sqrt{S_{yc}}} = 43.40$$

Johnson's equation will be in use to calculate the critical buckling load because the slenderness ratio is smaller than the transition slenderness ratio.

$$F_{cri} = A \left[S_{yt} - \frac{S_{yt}}{4\pi^2 E} \left(\frac{Le}{r_g} \right)^2 \right]$$

$$F_{cri} = 3793295.761 \text{ N} > 166800 \text{ N}$$

The applying load is less than buckling/crippling load; it is safe load.[3]

2.2.8 Blank tool

The maximum length of a blank tool may be calculated with the aid of Euler's formula, for blank tool fixed at one end and guided at the other end the critical force computed by the formula.

$$F_{cri} = \frac{2\pi^2 EI_{min}}{l^2}$$

If critical force equals blank tool force, then the maximum length of the punch may be calculated by the following formula,

$$l_{max} = \frac{\sqrt{2\pi^2 EI}}{\sqrt{P}}$$

$$l_{max} = 2544 \text{ mm}$$

This is the safe maximum length that can perform without failure.

Buckling for blank tool:

Tool material, D2 with a compressive strength of $2,200 \text{ N/mm}^2$ and modulus of elasticity, $E = 2.1 \times 10^5 \text{ mm}^2$.

Where, $L = 2l$ for one end fixed and other end free

$$L = 160 \text{ mm}$$

For Rectangular blank tool, $h = 80 \text{ mm}$, $b = 76 \text{ mm}$

$$I = \frac{bh^3}{12} = 3142666.76 \text{ mm}^4$$

$$A = b \times h = 6080 \text{ mm}^2$$

$$r_g = \frac{\sqrt{I}}{\sqrt{A}} = 23.09$$

$$\text{Slenderness ratio (S.R.)} = \frac{Le}{r_g} = 6.92$$

$$\text{Transition Slenderness ratio (T.S.R.)} = \frac{\sqrt{2\pi^2 E}}{\sqrt{S_{yc}}} = 43.40$$

Johnson's equation will be in use to calculate the critical buckling load because the slenderness ratio is smaller than the transition slenderness ratio.

$$F_{cri} = A \left[S_{yc} - \frac{S_{yc}}{4\pi^2 E} \left(\frac{Le}{r_g} \right)^2 \right]$$

$$F_{cri} = 13206026.16 > 237000 \text{ N}$$

The applying load is less than buckling/crippling load; it is safe load.[3]

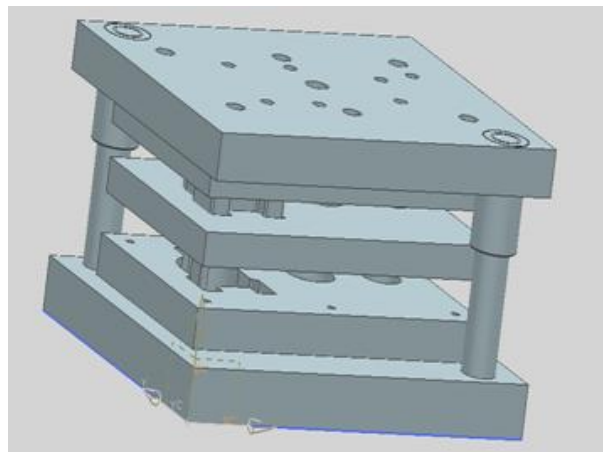

Fig. 2.1 model of progressive die

III. ANALYSIS

Sr. no.	Component	Material	Stresses (by calculation) (N/mm ²)	Stresses (by analysis) (N/mm ²)	
				maximum	minimum
1.	Punch plate	W.P.S.	19.92	1772.648	0.515
2.	Die plate	W.P.S.	16.23	5541.750	16.876

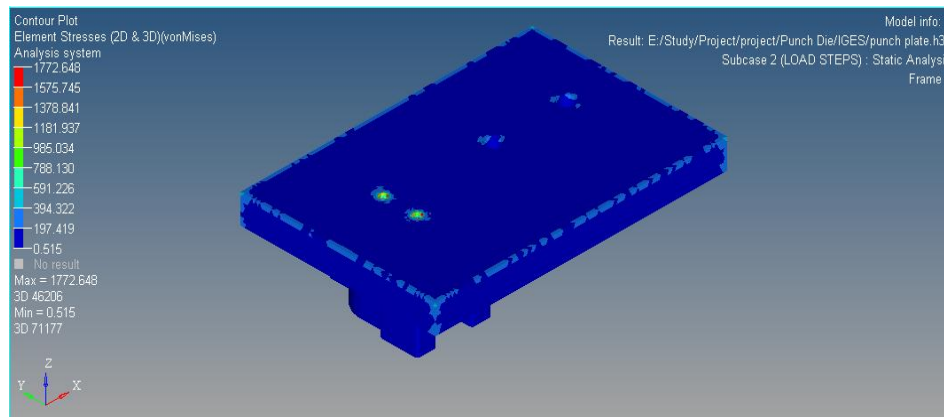

Fig3.1. stress analysis of punch plate

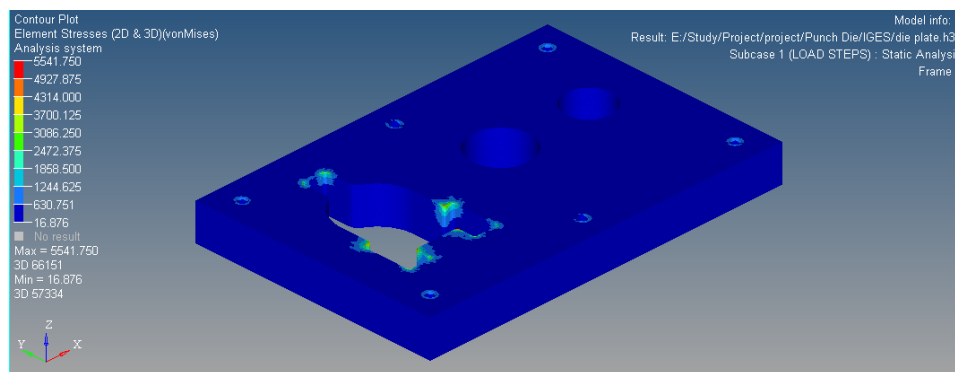

Fig3.2. stress analysis of die plate

IV. CONCLUSION

- 1) We studied the design procedure for progressive and simple die.
- 2) By calculating Die length, width, clearance we get to know various parameter consideration.
- 3) We learn 3-D geometry of die and its material selection with cost relationship considerations.
- 4) By analysing this die we can conclude progressive die has its initial cost very high but it can bring the revolution in the small scale industries if small scale industries install this die.
- 5) Progressive dies not only increases the production rate but also reduces man power.
- 6) By studying the applications, advantages of progressive dies we can conclude that progressive die can only use for batch and continues production.

REFERENCES

- [1] B. Jaya Laxmi et al. / International Journal of Research in Modern Engineering and Emerging Technology Vol. 2, Issue: 1, April-May : 2014 (IJRMEET) ISSN: 2320-6
- [2] H. Ameresh¹, P.Hari Shankar, International Journal of Computer Trends and Technology (IJCTT) – volume 4 Issue 7–July 2013 ISSN: 2231-2803 <http://www.ijcttjournal.org> Page 2197 Progressive Tool Design and Analysis for 49 Lever 5 Stage Tools
- [3] The International Journal Of Engineering And Science (IJES) Volume 3 Issue Pages 5-85 2014 ISSN (e): 2319 – 1813 ISSN (p): 2319 – 1805 www.theijes.com The IJES Page 75 Progressive Die Design for Self Explosive Reactive Armor Holder (Case Study at Bishoftu Motorization Industry-Ethiopia) Gashaw-Desie and YonasMitikuDegu
- [4] IJRET: International Journal of Research in Engineering and Technology eISSN: 2319-1163 | pISSN: 2321-7308
- [5] IJRET: International Journal of Research in Engineering and Technology eISSN: 2319-1163 | pISSN: 2321-7308
- [6] K.Kishore Kumar, A.Srinath. M.Naveen, R.D.pavankumar/ International Journal of Engineering Research and Applications (IJERA) ISSN: 2248-9622 www.ijera.com Vol. 2, Issue 3, May-Jun 2012, pp.2971-2978
- [7] International Journal of Engineering Research & Technology (IJERT) Vol. 1 Issue 6, August - 2012 ISSN: 2278-0181
- [8] Tool Design by Cyll Donaldson, George H Lecain, V C Goold -TATA McGRAW-HILL page no.678
- [9] Design Data Book-ISBN- 978-81-927355-0-4 by PSG College of Technology, Coimbatore. Page no.1.9,13.2,6.51