

AIR COMPRESSED VEHICLE

ShubhamSuryawanshi¹, YashBharade², Pratik Shetkar³, ChetanPakhale⁴

^{1,2,3,4}S.E. Scholar, Bvcoe & Ri Nashik,Pune University.(India)

ABSTRACT

Now a day`s the cost of fuels are increasing rapidly. People are very much cost concerned. It is not economical to run vehicle on conventional fuels. The stocks of conventional fuels are going to diminish; hence our product pneumatic vehicle can prove as a solution. In design, construction, and maintenance of any engineering system, engineers have to take many technological and managerial decisions at several stages. The ultimate goal of all such decisions is either to minimize the effort required or to maximize the desired benefit. In pneumatic vehicle, the energy of compressed air filled inside the tank mounted on the vehicle is utilized. After a drive the compressed air inside tank will be used up and need to be refill. In this project we have designed & manufactured a pneumatic vehicle that uses compressed air initially and after that the auxiliary cylinders recharges the air tank connected to the rear wheel of vehicle be refilled.

I. INTRODUCTION

Compressing a gas into a small space is the way of storing energy, when gas expands that energy is released to do work. This is the basic principle behind the pneumatic vehicle. In pneumatic vehicle, the energy of compressed air filled inside the tank mounted on the vehicle is utilized. After a drive the compressed air inside tank will be used up and need to be refilled. The first compressed air Engine was developed by French company Motor Development International (MDI). In this project we have designed & manufactured a pneumatic vehicle that uses compressed air initially and after that the auxiliary cylinders recharges the air tank connected to the rear wheel of vehicle.

1.1. Aim of Project

The aim of project is to design a model of such a vehicle which runs on non-conventional fuel (compressed air) & which is also eco friendly with minimum cost of manufacturing.

II. LITERATURE REVIEW

- Tata Motors has signed an agreement with Motor Development International of France to develop a car that runs on compressed air.
- The car – MiniCAT as shown in Fig 2.1 could cost around Rs 350,000 in India and would have a range of around 300 km between refuels.
- To fill the tanks it will take about to 2 to 3 minutes at a price of Rs 90. After refilling the car will be ready to driver 200 km.
- The car also has a small compressor that can be connected to an electrical network (220V or 380V) and will recharge the tanks completely in 3 or 4 hours.

- In the single energy mode MDI cars consume around Rs 45 every 100 km.



Fig. 2.1 Tata Motors –MiniCAT

2.1basic Principle of Pneumatic System

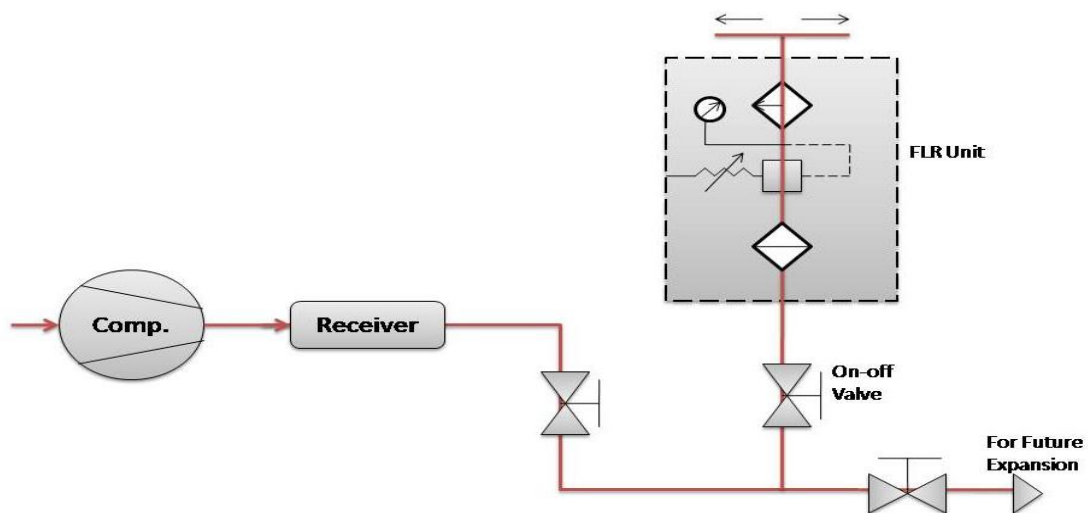

Fig. 2.3 Basic Pneumatic System

The basic layout of a pneumatic system is shown in Fig 2.3 It could be observed that the basic components involved are similar to a hydraulic system. The basic differences between hydraulic and pneumatic systems are that in hydraulic system the input mechanical energy is imparted to the oil is by pump, whereas, in pneumatic systems the working fluid being air, the mechanical energy is imparted to air by a compressor. Further, a hydraulic system usually operates at very high pressures to transmit the large force and power while a pneumatic system operates at low pressures of about 5 – 7 bar for industrial applications.

2.2 Components Of Pneumatic Vehicle Are

- 1) Pneumatic cylinder,
- 2) 5/2 Direction control valve,

- 3) Air circulating devices,
- 4) Air cylinder,
- 5) Bearing Mounter,
- 6) Shaft,
- 7) Chain sprocket,
- 8) Base frame

III. DESIGN AND MANUFACTURING OF PNEUMATIC VEHICLE

The design a pneumatic vehicle total design work has been divided into two parts mainly,

1. System Design
2. Mechanical Design

System design mainly concern with the various physical concerns and ergonomics, space requirements, arrangements of various components on the main frame of machine, number of controls, positions of this controls, ease of maintenance, scope of further improvements, height of machine components from the ground etc. In mechanical design, the components are categorized into two parts.

1. Design Parts
2. Parts to be purchased

For design parts, detailed design is done and dimensions thus obtained are compared to next highest dimensions which are readily available in the market.

3.1 DESIGN OF CHASSIS:

For chassis design refer Fig 3.1,

Let us assume that,

Weight of a person=60kg,

Weight of chassis & other accessories=40kg,

Therefore,

Total weight of the vehicle=100kg (Assuming)

Force =W x g

$$=100 \times 9.81$$

$$=981\text{N}$$

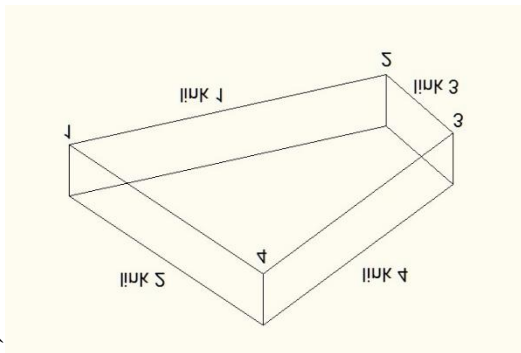

Fig 3.1. Sketch of chassis

There are 4 key points as shown in the figure where total weight acts. So, considering load is distributed equally at the each point i.e. on each link.

Force acting on each link(F_1)= 981/4

$$F_1 = 245.25\text{N}$$

Let,

$$=1222.80 \text{ mm}^4$$

$$I_{p2} = (I_{G2} + A_2 h_2^2)$$

$$= 1333.33 + \{ 40 \times (15.76 - 10)^2 \}$$

$$= 2660.434 \text{ mm}^4$$

So, Moment of inertia (I),

$$I = I_{p1} + I_{p2}$$

$$= 1222.80 + 2660.434$$

$$I = 3883.234 \text{ mm}^4$$

We know that,

$$(M/I) = (\sigma/y)$$

L_1 =Length of link 1=910mm

So, Bending Moment (M) for link 1 is given by,

$$M = F_1 \times L_1$$

$$= 245.25 \times (910/1000)$$

$$= 223.17 \text{ N-m}$$

We are using MS angle over MS flat cause MS angle has comparatively high strength in twisting & bending than MS flat.

So, Selecting MS angle of (22 x 22 x 2) mm dimension.

Calculating Moment of Inertia for MS angle (I),

$$I_G = (bd^3/12)$$

$$\sigma_{\text{permissible}} = (S_{ut}/N_f) = (650 / 2) = 325 \text{ N/mm}^2$$

$$I_{G1} = (22 \times 2^3) / 12 = 14.666 \text{ mm}^4$$

$$I_{G2} = (20^3 \times 2) / 12 = 1333.33 \text{ mm}^4$$

$$y = \text{C.G. of the system} = (A_1 y_1 + A_2 y_2) / (A_1 + A_2)$$

$$y = [\{ (22 \times 2) \times 2 \} + \{ (20 \times 2) \times 10 \}] / \{ (20 \times 2) + (22 \times 2) \}$$

$$y = 15.76 \text{ mm}$$

Now, I_p = Moment of Inertia about parallel axis.

$$= (I_G + Ah^2)$$

So,

$$I_{p1} = (I_{G1} + A_1 h_1^2)$$

$$= 14.666 + \{ 44 \times (21 - 15.76)^2 \}$$

$$= 0.33 \times 490.5$$

$$= 161.865 \text{ N}$$

For 2 rear wheels Resultant force,

$$F_R = 2 \times F_1$$

$$= 2 \times 161.865$$

$$= 323.73 \text{ N}$$

Torque transmitted (T),

$$T = F_R \times r$$

$$= 323 \times (300/2000)$$

$$T = 48.45 \text{ N-m}$$

Maximum Torsional shear stress (τ_{max}):

For shaft we are selecting C45 material.

$$\begin{aligned} \sigma_{\text{actual}} &= (M \times y) / I \\ &= (223.17 \times 10^3 \times 15.76) / 3883.234 \\ &= 90.572 \text{ N/mm}^2 \end{aligned}$$

As, $\sigma_{\text{actual}} < \sigma_{\text{permissible}}$

Design is safe.

3.2. SHAFT DESIGN:

Total Force acting on chassis = 981N

As, power is transmitted to rear axle only the force acting on chassis is equally distributed into rear tires.

$$R_A = R_B = 981/2 = 490.5 \text{ N}$$

Now, considering F.B.D. of tyre,

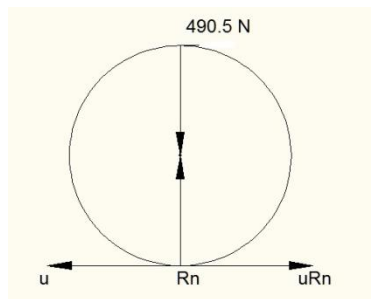

Fig 3.3 Cross – section of shaft

Where, μ = Frictional force = 0.33

R_N = Normal Reaction.

$$F_f = \mu \times R_N$$

T = Torque transmitted, N/mm^2

J = Polar moment of Inertia, mm^4

So, substituting values we get,

$$(74.25 / [d/2]) = ([48.45 \times 10^3] / [\pi d^4/32])$$

$$d^3 = 3330.1430$$

$$d = 14.933 \text{ mm}$$

So, for safety we are selecting the shaft diameter $d = 20 \text{ mm}$.

As, Intermediate shaft also had to transmit same torque & also its length is smaller than that of rear shaft. We are selecting same material & Same Diameter of shaft 20mm.

3.4. DESIGN OF PISTON & CYLINDERS:

Diameter of gear = 120mm

No. of teeth on gear = $Z_1 = 60$

So, for C45

S_{yt} = Yield strength of shaft material = 330 N/mm^2 ,

S_{ut} = Tensile strength of shaft material = 60 N/mm^2 ,

According to A.S.M.E. code,

$$(\tau_{\text{max}}) = 0.18 S_{ut} = 0.18 \times 600 = 108 \text{ N/mm}^2$$

OR

$$= 0.3 S_{yt} = 0.3 \times 330 = 99 \text{ N/mm}^2$$

$\tau_{\text{max}} = 99 \text{ N/mm}^2$ (Selecting minimum value),

so,

$$\tau_{\text{max}} = 99 \times 0.75$$

$$= 74.25 \text{ N/mm}^2$$

Now,

$$(\tau_{\text{max}} / R) = (T / J)$$

Where, τ_{max} = maximum torsional shear stress, N/mm^2

R = Radius of shaft, mm

$$= (48.45/2)$$

$$= 24.225 \text{ N-m}$$

Piston Rod is connected to the gear with eccentricity distance of 45mm.

Let, R_1 = distance between C.G. of gear & eccentricity.

Diameter of gear (D) = 120mm

$$R = D/2 = 60 \text{ mm}$$

$$\text{So, } R_1 = \{R - (15 \text{ mm})\}$$

$$= (60 - 15)$$

$$R_1 = 45 \text{ mm}$$

$$\text{Force} = (T/R_1)$$

$$= (24.225 \times 10^3) / 45$$

$$= 538.333 \text{ N}$$

This is the force on a piston for 1 stroke.

Let us , assume that standard bore diameter of

Diameter of pinion=160mm
 No. of teeth on pinion = $z_2=30$
 So, module (m) = $(120/60) = (60/30) = 2$
 Torque transmitted to pinion = 48.45 N-m

As, pinion is mounted on intermediate shaft which is connected to the rear shaft with the help of sprocket & chain assembly.

So, Torque transmitted to pinion = 48.45N-m

Gear Reduction Ratio (G) = z_1 / z_2
 $= 60/30$
 $= 2$

Torque Transmitted from gear = (T/2)

This is required pressure to move the vehicle initially from rest position. But, as we want to

move the vehicle upto speed range of 15 -20 km/hr we Have to take pressure of 4bar inside air receiver tank.

So, selecting working pressure ($P_{working}$) = 4 bar

Now, considering vehicle is moving with 15-20 km/hr where working pressure inside tank is 4 bar.so, for safety we will select the master cylinder of pressure 10 bar.

Selecting 10 bar master cylinder with stroke length=100mm, Bore diameter=50mm.

So, our initial assumption of Bore diameter of 50mm & gear diameter of 120mm is true & design is safe.

As, stroke Length of piston is 100mm so we are selecting gear of diameter 120mm.so our initial assumption is also true.

3.5. DESIGN FOR PRESSURE VESSEL:

Let,

d=diameter of pipe=170mm,

t=thickness of pipe=5m,

L=length of cylinder=280mm.

So,

$(d/t)=(170/5) = 34 > 20$

So, designing pressure vessel as a thin cylinder.

Radial forces acting in thin cylinder can be neglected.

Volume of tank (V) = $(\pi/4) \times d^2 \times L$

cylinder be 50mm.

Area of cylinder (A) = $(\pi/4) \times D^2$

$= (\pi/4) \times (50)^2$

$= 1963.49\text{mm}^2$

$= 1963.49 \times 10^{-4} \text{m}^2$

Required pressure inside air receiver tank (P_{req}),

$P_{req} = (F/A)$

$= 538.333 / (1963.49 \times 10^{-4})$

$= 2741.71 \text{N/m}^2$

Now considering vehicle should move upto 15 m once the air receiver tank is filled.

Diameter of rear tyre (D) = 300 mm

So for 1 rotation = $\pi \times D$

$= \pi \times 0.3$

$= 0.94 \text{m}$

So for 15 m rotation of tyre = $(15 \times 1) / 0.94$

$= 15.95$

$= 16 \text{rotations}$

As, pinion is on the intermediate shaft which is connected to rear shaft with chain sprocket, so for 16 rotations of tyre there are same rotations of pinion

So rotations of pinion = 16 rotations

For gear = $(16 / 2) = 8 \text{rotations}$

For piston = 16 oscillations.

For 2 oscillations i.e. for forward & return stroke there is 1 complete rotation of gear.

So volume exhausted per stroke of piston = $(\pi/4) \times D^2 \times L$

$= (\pi/4) \times 50^2 \times 100$

$= 1.963 \times 10^{-4} \text{m}^3/\text{stroke}$

So for 1 rotation of gear there are 2 strokes

3.7 DIRECTION CONTROL VALVE

3.7.1 HAND LEVER VALVE :

Pipe size: 1/ 4", 3/8", and 1 / 2" BSP

$$= (\pi/4) \times 170^2 \times 280$$

$$V = 6.355 \times 10^{-3} \text{ m}^3$$

$$V_{\text{theoretical}} = 6.3 \text{ lit.}$$

So volume exhausted per 1 rotation of gear = $2 \times 1.963 \times 10^{-4}$

$$= 3.9268 \times 10^{-4} \text{ m}^3$$

$$= 0.3926 \text{ lit.}$$

For 16 oscillations of piston

Calculated volume = (volume/stroke) x oscillations of piston

$$= 0.392 \times 16$$

$$V_{\text{calculated}} = 6.28 \text{ lit.}$$

$$V_{\text{calculated}} < V_{\text{theoretical}}$$

Hence design is safe.

So, for 15 m traveled distance piston will oscillate inside the cylinder 16 times & 6.28 lit compressed air is used from the air receiver tank.

So the initial assumptions of diameter and length of cylinder is correct.

Diameter of cylinder = 170 mm

Length of cylinder = 280 mm

Thickness of cylinder = 5 mm

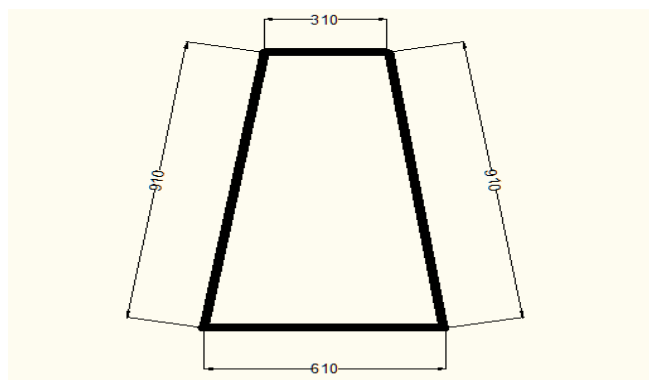

Media : air

No. of ways : 5 & 2 way

Actuation : hand lever

Return Mechanism: spring push-pull

Pressure Machine : 0-10 Kg / cm²

Spool type : 2 & 3 position with or without

Detent valve body: Aluminum

3.6 MANUFACTURING OF FRAME BASE:

It forms the robust support to stand the machine vertically. It holds the weight of the vertical post and supports the air receiver tank. It is made of mild steel channels of size (22 x 22 x 2) mm cross section and 910 x 310 x 610 x 160 mm of trapezoidal base

3.13 Advantages Of Pneumatic Vehicle

1. Eco-friendly.
2. It uses non-conventional energy.
3. Easy Manufacturing.
4. Economical One.
5. Can be built up to various capacities easily.
6. Easy Construction.
7. Low maintenance cost.

3.14. Drawbacks Of Pneumatic Vehicle

1. Large Storage Space.
2. Necessity of Compressor.
3. Less carrying capacity.
4. Starting system is difficult.

3.15 Applications

Though air powered cars are meant mainly for individual consumers in urban areas most of the early adopters will be businesses like taxi services and local transport. Also products are manufactured for the. Each vehicle is equipped with the same type of engine power output of 25HP with a maximum speed of 68mph.

Following are some of the models developed by MDI:

3.15.1. Family Car

- Description: A spacious car with seats which can face different directions. The vehicles design is based on needs of typical family
- Features: Airbag, air conditioning, 6 seats (Refer fig no. 3.10)

IV. RESULT ANALYSIS

The air receiver tank is filled with compressed air and maintained at 4 bar. Then flow control valve is closed so that air remains in air receiver. Through double acting cylinder, piston movement is carried out with the help of pneumatic 5/2 direction control valve. Slider crank mechanism is used to transmit the piston rod movement to the rear axle through the gear pairs.

Following results are obtained from experimental analysis:

Table no. 4.1 Result Analysis Table

| TEST | RESULT |
|---|---------|
| Time require to fill the tank | 4 sec |
| Distance travelled by car in single filling of tank | 25m |
| Load carrying capacity | 60kg |
| Length traveled in 1 stroke | 5m |
| Volume of air receiver tank | 6.3lit. |

The pneumatic vehicle model designed and manufactured was tested and performance was found satisfactory.

V. FUTURE MODIFICATIONS

It is always consider that every machine should perform satisfactorily but due to theoretical assumptions differ from actual practice so to overcome this drawback some modifications are needed. These modifications may be in design or may be in performance or may be in features of product. It is also not possible to develop a model which works on ideal conditions. According to customer requirement, market value & necessity of product some changes may be done. These changes may vary according to condition. The future modification is done for improving performance of product & increasing the life of product. For pneumatic vehicle there are lots of scopes to modify the performance, features design.

5.1. Load carrying capacity

As we know the load carrying capacity of pneumatic vehicle is less. It is due to the low torque developed at low pressure. As the torque is increased the load carrying capacity is also increased this may be done by increasing the pressure in the air receiver tank. This is one of the major & very important modification can be done in the pneumatic vehicle.

5.2. Low speed of vehicle

The name itself indicates the function of vehicle but the major drawback of this; vehicle is not running continuously more than 20kmph.

To overcome this drawback we can get a continuous motion with more speed by using the solenoid valve with reset timer. Using this mechanism vehicle will move continuously without stop & we can achieve the speed more than 20kmph

5.3. Large storage space

As we know for working the pneumatic vehicle we require an initial compress air in air receiver tank. This tank is heavy in weight & big in size. Due to this the space as well as the cost is increase. This is not feasible. To overcome this drawback we can use the low weight metal with high tensile strength & to decrease the size with require press we can use the bio-fuel.

VI. CONCLUSION

Even though the vehicle is in early stage of development, it holds a lot of promise and provides scope for further research. Thus we designed and manufactured the vehicle model which is eco friendly and does not cause pollution like internal combustion engines. This vehicle will help in reducing the problem of global warming since internal combustion engines contribute to the problem the most. It uses non-conventional energy source i.e. atmospheric air. This will help to save the non renewable sources of energy. So, the successful policy for the 21st century will depend on the non conventional sources. Pneumatic vehicle can prove solution to depleting natural resources and can be the technology of tomorrow. In this project a model of pneumatic vehicle is designed and manufactured. The load carrying capacity of pneumatic vehicle is 60 kg. the volume of air receiver

tank is 6.3 lit. and is stored at pressure of 4 bar. Once the compressed air is filled in tank the vehicle can move upto a distance of 15 to 20 m.

final model of pneumatic vehicle

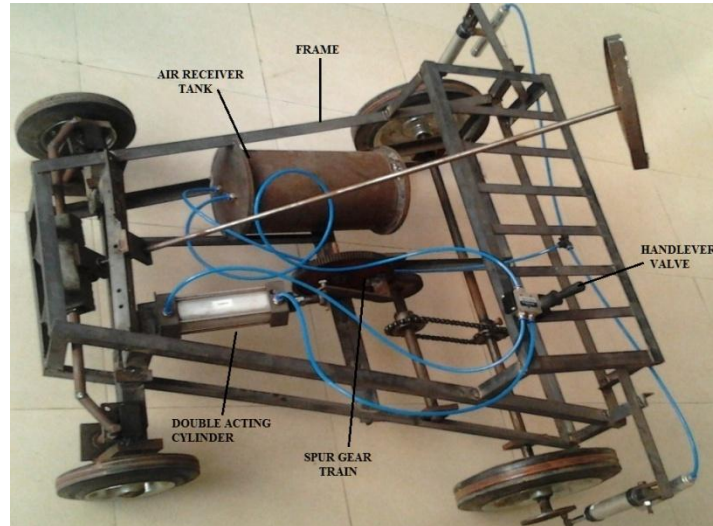

Fig 3.9 Manufactured Vehicle