

Improved iUPQC Controller for Additional Grid Voltage Regulation as a STATCOM

¹P Ramreddy

*Department of EEE, Kamala Institute of
Technology and Science
peddiramreddy@gmail.com.*

²Dr. D Ramakrishna reddy

*Department of EEE, Chaitanya
(Deemed to be University),
ramakrishnareddy.donapati@gmail.com*

ABSTRACT

This work describes an upgraded controller for the dual topology of the unified power quality conditioner (iUPQC), which expands its applicability in power-quality compensation and microgrid applications. In addition to the typical UPQC power quality features, such as voltage sag/swell compensation, the iUPQC will provide reactive power support to manage not only the load-bus voltage but also the voltage at the grid-side bus. In other words, the iUPQC will function as a static synchronous compensator (STATCOM) on the grid while also offering traditional UPQC compensations on the load or microgrid side. The experimental findings are supplied to confirm the new functionality of the equipment.

1.1 INTRODUCTION

Certainly, power-electronics devices have brought about great technological improvements. However, the increasing number of power-electronics-driven loads used generally in the industry has brought about uncommon power quality problems. In contrast, power-electronics-driven loads generally require ideal sinusoidal supply voltage in order to function properly, whereas they are the most responsible ones for abnormal harmonic currents level in the distribution system. In this scenario,

devices that can mitigate these drawbacks have been developed over the years. Some of the solutions involve a flexible compensator, known as the unified power quality conditioner (UPQC) and the static synchronous compensator (STATCOM).

The power circuit of a UPQC consists of a combination of a shunt active filter and a series active filter connected in a back-to-back configuration. This combination allows the simultaneous compensation of the load current and the supply voltage, so that the compensated current drawn from the grid and the compensated supply voltage delivered to the load are kept balanced and sinusoidal. The dual topology of the UPQC, i.e., the iUPQC, was presented in [14]–[19], where the shunt active filter behaves as an ac-voltage source and the series one as an ac-current source, both at the fundamental frequency. This is a key point to better design the control gains, as well as to optimize the *LCL* filter of the power converters, which allows improving significantly the overall performance of the compensator.

The STATCOM has been used widely in transmission network to regulate the voltage by means of dynamic reactive power compensation. Nowadays, the STATCOM is largely used for voltage regulation [9], whereas the UPQC and the iUPQC have been selected as solution for more

specific applications[21]. Moreover, these last ones are used only in particular cases, where their relatively high costs are justified by the power quality improvement it can provide, which would be feasible by using conventional solutions.

By joining the extra functionality like a STATCOM in the iUPQC device, a wider scenario of applications can be reached, particularly in case of distributed generation in smart grids and as the coupling device in grid-tied micro grids. In [16], the performance of the iUPQC and the UPQC was compared when working as UPQCs. The main difference between these compensators is the sort of source emulated by the series and shunt power converters. In the UPQC approach, the series converter is controlled as a non sinusoidal voltage source and the shunt one as a non sinusoidal current source. Hence, in real time, the UPQC controller has to determine and synthesize accurately the harmonic voltage and current to be compensated. On the other hand, in the iUPQC approach, the series converter behaves as a controlled sinusoidal current source and the shunt converter as a controlled sinusoidal voltage source.

This means that it is not necessary to determine the harmonic voltage and current to be compensated, since the harmonic voltages appear naturally across the series current source and the harmonic currents flow naturally into the shunt voltage source. In actual power converters, as the switching frequency increases, the power rate capability is reduced.

Therefore, the iUPQC offers better solutions if compared with the UPQC in case of high-power applications, since the iUPQC compensating references are pure sinusoidal waveforms at the fundamental frequency. Moreover,

the UPQC has higher switching losses due to its higher switching frequency.

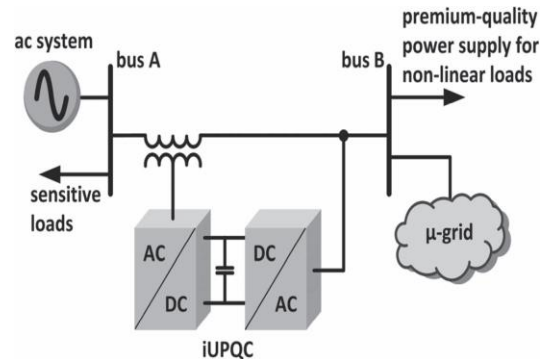

Fig. 1.1. Example of applicability of iUPQC.

2.1. Classification of Power Quality Problems

This IEEE defined power quality disturbances shown in this paper have been organized into seven categories based on wave shape:

1. Transients.
2. Interruptions.
3. Sag / under voltage.
4. Swell / Overvoltage.
5. Waveform distortion.
6. Voltage fluctuations.
7. Frequency variations.

2.2. Solutions to Power Quality Problems:

Solutions will play a major role in improving the inherent supply quality; some of the effective and economic measures can be identified as following:

A. Thyristor Based Static Switches:

The static switch is a versatile device it has a dynamic response time of about one cycle. To correct quickly for voltage spikes, sags or interruptions, the static switch can be used to switch one or more of devices such as capacitor, filter, alternate power line, energy storage systems etc. The static switch can be used in the alternate power line applications. This scheme requires two independent power lines from the utility or could be from utility and localized power generation like those in case of distributed generating systems [4]. Such a scheme

can protect up to about 85 % of interruptions and voltage sags.

B. Energy Storage Systems:

Storage systems can be used to protect sensitive production equipment from shutdowns caused by voltage sags or momentary interruptions. These are usually DC storage systems such as UPS, batteries, superconducting magnet energy storage (SMES), storage capacitors or even fly wheels driving DC generators . The output of these devices can be supplied to the system through an inverter on a momentary basis by a fast acting electronic switch. Enough energy is fed to the system to compensate for the energy that would be lost by the voltage sag or interruption. In case of utility supply backed by a localized generation this can be even better accomplished.

C. Harmonic Filters:

Filters are used in some instances to effectively reduce or eliminate certain harmonics. If possible, it is always preferable to use a 12-pulse or higher transformer connection, rather than a filter. Tuned harmonic filters should be used with caution and avoided when possible. Usually, multiple filters are needed, each tuned to a separate harmonic. Each filter causes a parallel resonance as well as a series resonance, and each filter slightly changes the resonances of other filters.

D. Constant-Voltage Transformers:

For many power quality studies, it is possible to greatly improve the sag and momentary interruption tolerance of a facility by protecting control circuits. Constant voltage transformer (CVTs) can be used on control circuits to provide constant voltage with three cycle ride through, or relays and ac contactors can be provided with electronic coil hold-in devices to prevent mis-operation from either low or interrupted voltage.

E. Digital-Electronic and Intelligent Controllers for Load-Frequency Control:

Frequency of the supply power is one of the major determinants of power quality, which affects the equipment performance very drastically. Even the major system components such as Turbine life and interconnected-grid control are directly affected by power frequency. Load frequency controller used specifically for governing power frequency under varying loads must be fast enough to make adjustments against any deviation.

3.1 STATCOM:

In 1999 the first SVC with Voltage Source Converter called STATCOM (Static Compensator) went into operation. The STATCOM has a characteristic similar to the synchronous condenser, but as an electronic device it has no inertia and is superior to the synchronous condenser in several ways, such as better dynamics, a lower investment cost and lower operating and maintenance costs.

A STATCOM is build with Thyristors with turn-off capability like GTO or today IGCT or with more and more IGBTs. The static line between the current limitations has a certain steepness determining the control characteristic for the voltage.

The advantage of a STATCOM is that the reactive power provision is independent from the actual voltage on the connection point. This can be seen in the diagram for the maximum currents being independent of the voltage in comparison to the SVC. This means, that even during most severe contingencies, the STATCOM keeps its full capability.

In the distributed energy sector the usage of Voltage Source Converters for grid interconnection is common practice today. The next step in STATCOM development is the combination with

energy storages on the DC-side. The performance for power quality and balanced network operation can be improved much more with the combination of active and reactive power.

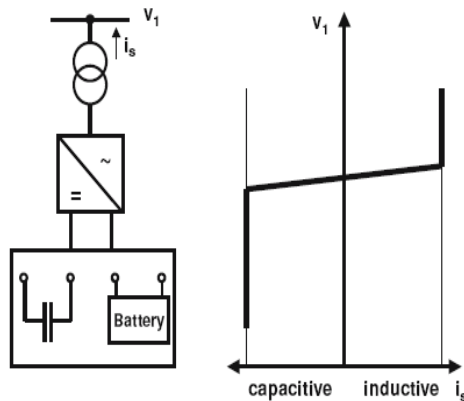

Fig.3.1 STATCOM structure and voltage / current characteristic

The STATCOM is a very fast acting, electronic equivalent of a synchronous condenser. If the STATCOM voltage, V_s , (which is proportional to the dc bus voltage V_c) is larger than bus voltage, E_s , then leading or capacitive VARS are produced. If V_s is smaller than E_s then lagging or inductive VARS are produced.

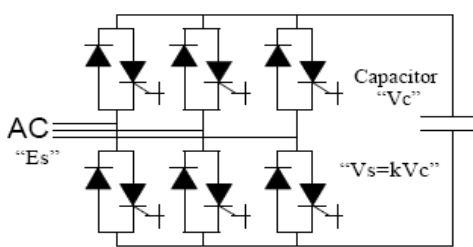
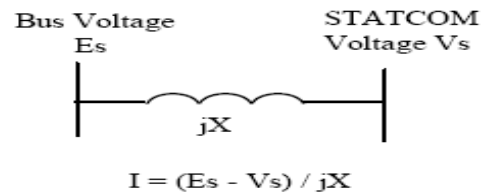

Fig.3.2 6 pulses STATCOM.

The three phases STATCOM makes use of the fact that on a three phase, fundamental frequency, steady state basis, and the instantaneous power entering a purely reactive device must be zero. The reactive power in each phase is supplied by circulating the instantaneous real power between the phases. This is achieved by firing the GTO/diode

switches in a manner that maintains the phase difference between the ac bus voltage E_s and the STATCOM generated voltage V_s . Ideally it is possible to construct a device based on circulating instantaneous power which has no energy storage device (ie no dc capacitor). A practical STATCOM requires some amount of energy storage to accommodate harmonic power and ac system unbalances, when the instantaneous real power is non-zero. The maximum energy storage required for the STATCOM is much less than for a TCR/TSC type of SVC compensator of comparable rating.



3.3 Series Devices:

Series devices have been further developed from fixed or mechanically switched compensations to the Thyristor Controlled Series Compensation (TCSC) or even Voltage Source Converter based devices.

The main applications are:

1. Reduction of series voltage decline in magnitude and angle over a power line,
2. Reduction of voltage fluctuations within defined limits during changing power transmissions,
3. Improvement of system damping resp. damping of oscillations,

3.1.(a) TCSC:

Thyristor Controlled Series Capacitors (TCSC) address specific dynamical problems in transmission systems. Firstly it increases damping when large electrical systems are interconnected. Secondly it can overcome the problem of Sub Synchronous Resonance (SSR), a phenomenon that involves an interaction between large thermal

generating units and series compensated transmission systems. The TCSC's high speed switching capability provides a mechanism for controlling line power flow, which permits increased loading of existing transmission lines, and allows for rapid readjustment of line power flow in response to various contingencies. The TCSC also can regulate steady-state power flow within its rating limits.

From a principal technology point of view, the TCSC resembles the conventional series capacitor. All the power equipment is located on an isolated steel platform, including the Thyristor valve that is used to control the behavior of the main capacitor bank. Likewise the control and protection is located on ground potential together with other auxiliary systems. Figure shows the principle setup of a TCSC and its operational diagram. The firing angle and the thermal limits of the Thyristors determine the boundaries of the operational diagram.

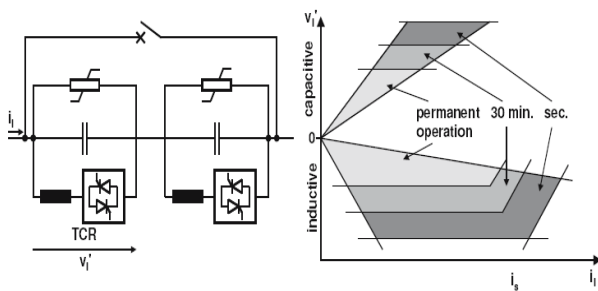

Fig.3.4 TCSC Dynamical problems in transmission system.

Advantages

1. Improved capacitor bank protection
2. Local mitigation of sub synchronous resonance (SSR). This permits higher levels of compensation in networks where interactions with turbine-generator torsional vibrations or with other control or measuring systems are of concern.

3. Damping of electromechanical (0.5-2 Hz) power oscillations which often arise between areas in a large interconnected power network. These oscillations are due to the dynamics of inter area power transfer and often exhibit poor damping when the aggregate power transfer over a corridor is high relative to the transmission strength.

3.2 Shunt and Series Devices:

3.2(a) Dynamic Power Flow Controller:

A new device in the area of power flow control is the Dynamic Power Flow Controller (DFC). The DFC is a hybrid device between a Phase Shifting Transformer (PST) and switched series compensation.

A functional single line diagram of the Dynamic Flow Controller is shown in Figure 1.19. The Dynamic Flow Controller consists of the following components:

1. A standard phase shifting transformer with tap-changer (PST).
2. Series-connected Thyristor Switched Capacitors and Reactors (TSC / TSR).
3. A mechanically switched shunt capacitor (MSC). (This is optional depending on the system reactive power requirements).

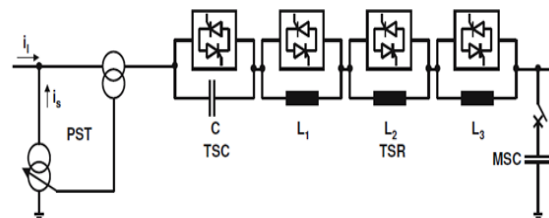

Fig.3.5 Principle configuration of DFC.

Based on the system requirements, a DFC might consist of a number of series TSC or TSR. The mechanically switched shunt capacitor (MSC) will provide voltage support in case of overload and

other conditions. Normally the reactance of reactors and the capacitors are selected based on a binary basis to result in a desired stepped reactance variation. If a higher power flow resolution is needed, a reactance equivalent to the half of the smallest one can be added.

The switching of series reactors occurs at zero current to avoid any harmonics. However, in general, the principle of phase-angle control used in TCSC can be applied for a continuous control as well. The operation of a DFC is based on the following rules:

1. TSC / TSR are switched when a fast response is required.
2. The relieve of overload and work in stressed situations is handled by the TSC / TSR.
3. The switching of the PST tap-changer should be minimized particularly for the currents higher than normal loading.
4. The total reactive power consumption of the device can be optimized by the operation of the MSC, tap changer and the switched capacities and reactors.

In order to visualize the steady state operating range of the DFC, we assume an inductance in parallel representing parallel transmission paths. The overall control objective in steady state would be to control the distribution of power flow between the branch with the DFC and the parallel path. This control is accomplished by control of the injected series voltage.

The PST (assuming a quadrature booster) will inject a voltage in quadrature with the node voltage. The controllable reactance will inject a voltage in quadrature with the throughput current. Assuming that the power flow has a load factor close to one, the two parts of the series voltage will be close to collinear. However, in terms of speed of

control, influence on reactive power balance and effectiveness at high/low loading the two parts of the series voltage has quite different characteristics. The steady state control range for loadings up to rated current is illustrated in Figure 3.14, where the x-axis corresponds to the throughput current and the y-axis corresponds to the injected series voltage.

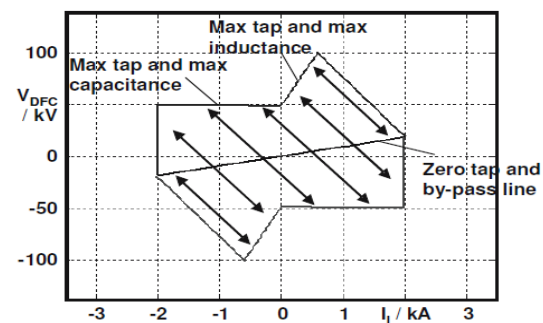

Fig.3.6 Operational diagram of a DFC

Operation in the first and third quadrants corresponds to reduction of power through the DFC, whereas operation in the second and fourth quadrants corresponds to increasing the power flow through the DFC. The slope of the line passing through the origin (at which the tap is at zero and TSC / TSR are bypassed) depends on the short circuit reactance of the PST.

Starting at rated current (2 kA) the short circuit reactance by itself provides an injected voltage (approximately 20 kV in this case). If more inductance is switched in and/or the tap is increased, the series voltage increases and the current through the DFC decreases (and the flow on parallel branches increases). The operating point moves along lines parallel to the arrows in the figure. The slope of these arrows depends on the size of the parallel reactance. The maximum series voltage in the first quadrant is obtained when all inductive steps are switched in and the tap is at its maximum.

Now, assuming maximum tap and inductance, if the throughput current decreases (due

e.g. to changing loading of the system) the series voltage will decrease.

At zero current, it will not matter whether the TSC / TSR steps are in or out, they will not contribute to the series voltage. Consequently, the series voltage at zero current corresponds to rated PST series voltage.

Next, moving into the second quadrant, the operating range will be limited by the line corresponding to maximum tap and the capacitive step being switched in (and the inductive steps bypassed). In this case, the capacitive step is approximately as large as the short circuit reactance of the PST, giving an almost constant maximum voltage in the second quadrant.

3.2(b) Unified Power Flow Controller:

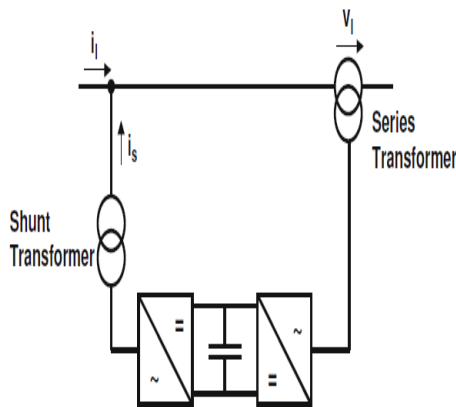

Fig3.7 Principle configuration of an UPFC

The UPFC consists of a shunt and a series transformer, which are connected via two voltage source converters with a common DC-capacitor. The DC-circuit allows the active power exchange between shunt and series transformer to control the phase shift of the series voltage. This setup, as shown in Figure 1.21, provides the full controllability for voltage and power flow. The series converter needs to be protected with a Thyristor bridge. Due to the high efforts for the Voltage Source Converters and the protection, an

UPFC is getting quite expensive, which limits the practical applications where the voltage and power flow control is required simultaneously.

4. UNIFIED POWER QUALITY CONDITIONER

The provision of both DSTATCOM and DVR can control the power quality of the source current and the load bus voltage. In addition, if the DVR and STATCOM are connected on the DC side, the DC bus voltage can be regulated by the shunt connected DSTATCOM while the DVR supplies the required energy to the load in case of the transient disturbances in source voltage. The configuration of such a device (termed as Unified Power Quality Conditioner (UPQC)) is shown in Fig. 4.1 This is a versatile device similar to a UPFC. However, the control objectives of a UPQC are quite different from that of a UPFC.

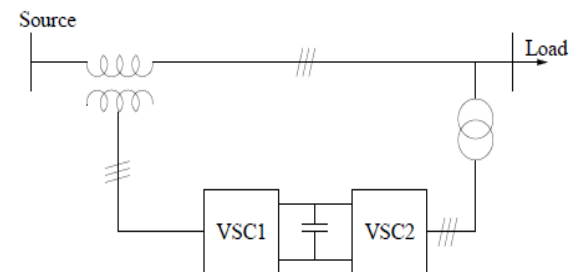

Fig. 4.1 Unified Power Quality Conditioner

4.1 CONTROL OBJECTIVES OF UPQC

The shunt connected converter has the following control objectives

1. To balance the source currents by injecting negative and zero sequence components required by the load
2. The compensate for the harmonics in the load current by injecting the required harmonic currents
3. To control the power factor by injecting the required reactive current (at fundamental frequency)

4. To regulate the DC bus voltage.

The series connected converter has the following control objectives

1. To balance the voltages at the load bus by injecting negative and zero sequence voltages to compensate for those present in the source.
2. To isolate the load bus from harmonics present in the source voltages, by injecting the harmonic voltages
3. To regulate the magnitude of the load bus voltage by injecting the required active and reactive components (at fundamental frequency) depending on the power factor on the source side
4. To control the power factor at the input port of the UPQC (where the source is connected. Note that the power factor at the output port of the UPQC (connected to the load) is controlled by the shunt converter.

4.2 Operation of UPQC

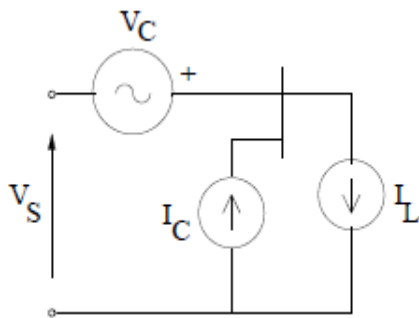

Fig. 4.2 Idealized Equivalent Circuit

The operation of a UPQC can be explained from the analysis of the idealized equivalent circuit shown in Fig.4.2. Here, the series converter is represented by a voltage source \$V_C\$ and the shunt converter is represented by a current source \$I_C\$.

Note : That all the currents and voltages are 3 dimensional vectors with phase coordinates. Unlike in the case of a UPFC (discussed in chapter 8), the voltages and currents may contain negative

and zero sequence components in addition to harmonics.

Neglecting losses in the converters, we get the relation

$$\langle V_L, I_C \rangle + \langle V_C, I_S \rangle = 0$$

where \$X, Y\$ denote the inner product of two vectors, defined by

$$\langle X, Y \rangle = \frac{1}{T} \int_0^T X^t(\tau) Y(\tau) d\tau.$$

Let the load current \$I_L\$ and the source voltage \$V_S\$ be decomposed into two Components given by

$$I_L = I_L^{1p} + I_L^r$$

$$V_S = V_S^{1p} + V_S^r$$

Where \$I_L^{1p}\$ contains only positive sequence, fundamental frequency components. Similar comments apply to \$V_S^{1p}\$. \$I_L^r\$ and \$V_S^r\$ contain rest of the load current and the source voltage including harmonics. \$I_L^{1p}\$ is not unique and depends on the power factor at the load bus. However, the following relation applies for \$I_L^{1p}\$.

$$P_L = \langle V_L, I_L \rangle = \langle V_L, I_L^{1p} \rangle$$

This implies that \$\langle V_L, I_L^r \rangle = 0\$. Thus, the fundamental frequency, positive sequence component in \$I_L^r\$ does not contribute to the active power in the load. To meet the control objectives, the desired load voltages and source currents must contain only positive sequence, fundamental frequency components and

$$P_L = |V_L^* I_S^*| \cos \phi_l = |V_S^{1p} I_S^*| \cos \phi_s$$

where \$V \square L\$ and \$I \square S\$ are the reference quantities for the load bus voltage and the source current respectively. \$\phi_l\$ is the power factor angle at

the load bus while ϕ_s is the power factor angle at the source bus (input port of UPQC). Note that $V_L(t)$ and $I_S(t)$ are sinusoidal and balanced. If the reference current (I_C^*) of the shunt converter and the reference voltage (V_C^*) of the series converter are chosen as

$$I_C^* = I_L^*, \quad V_C^* = -V_S^r + V_C^{1p}$$

with the constraint

$$\langle V_C^{1p}, I_S^* \rangle = 0$$

we have,

$$I_S^* = I_L^{1p}, \quad V_L^* = V_S^{1p} + V_C^{1p}$$

Note that the constraint (14.30) implies that V_C^{1p} is the reactive voltage in quadrature with the desired source current, I_S^* . It is easy to derive that

$\langle V_C^*, I_S^* \rangle = 0 = \langle I_C^*, V_L^* \rangle$ The above equation shows that for the operating conditions assumed, a UPQC can be viewed as a inaction of a DVR and a STATCOM with no active power flow through the DC link.

However, if the magnitude of V_C^* is to be controlled, it may not be feasible to achieve this by injecting only reactive voltage. The situation gets complicated if V_C^{1p} is not constant, but changes due to system disturbances or fault. To ensure the regulation of the load bus voltage it may be necessary to inject variable active voltage (inphase with the source current). If we express

$$V_C = V_C^* + \Delta V_C, I_C = I_C^* + \Delta I_C$$

$$I_S = I_S^* - \Delta I_C, V_L = V_S^{1p} + V_C^{1p} + \Delta V_C$$

$$\langle I_S, \Delta V_C \rangle + \langle V_L, \Delta I_C \rangle = 0$$

In deriving the above, we assume that

$$\langle I_S, V_C^* \rangle = 0 = \langle V_L, I_C^* \rangle$$

This implies that both ϕ_{VC} and ϕ_{IC} are perturbations involving positive sequence, fundamental frequency quantities (say, resulting from symmetric voltage sags). the power balance on the DC side of the shunt and series converter. The perturbation in V_C is initiated to ensure that

$$|V_C^* + \Delta V_C + V_S| = |V_L| = \text{constant.}$$

Thus, the objective of the voltage regulation at the load bus may require exchange of power between the shunt and series converters.

Remarks

1. The unbalance and harmonics in the source voltage can arise due to uncompensated nonlinear and unbalanced loads in the upstream of the UPQC.
2. The injection of capacitive reactive voltage by the series converter has the advantage of raising the source voltage magnitude.

5. MODELING OF CASE STUDY

5.1 SYSTEM CONFIGURATION

In order to clarify the applicability of the improved Iupqc controller, Fig depicts an electrical system with two buses in spotlight, i.e., bus A and bus B. Bus A is a critical bus of the power system that supplies sensitive loads and serves as point of coupling of a microgrid. Bus B is a bus of the microgrid, where nonlinear loads are connected, which requires premium-quality power supply. The voltages at buses A and B must be regulated, in order to properly supply the sensitive loads and the nonlinear loads.

The effects caused by the harmonic currents drawn by the nonlinear loads should be mitigated, avoiding harmonic voltage propagation to bus A. The use of a STATCOM to guarantee the voltage regulation at bus A is not enough because the

converter can be set arbitrarily. In this case, it is necessary to provide an energy source (or large energy storage) associated to the dc link of the iUPQC. The last degree of freedom is represented by a reactive-power control variable q for the series converter of the iUPQC. In this way, the iUPQC will provide reactive-power compensation like a STATCOM to the bus A of the grid. As it will be confirmed, this functionality can be added into the controller without degrading all other functionalities of the iUPQC.

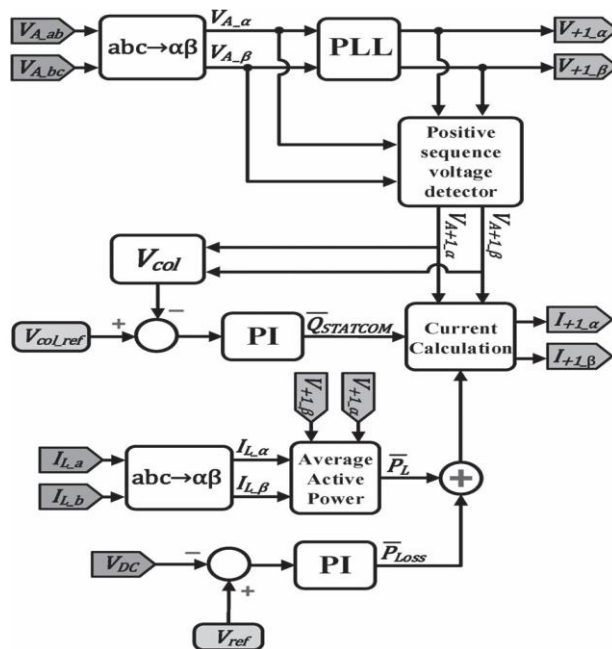

Fig.5.2. Novel iUPQC controller.

5.2 IMPROVED IUPQC CONTROLLER

5.2.1 Main Controller

The controller inputs are the voltages at buses A and B, the current demanded by bus B (i_L), and the voltage v_{DC} of the common dc link. The voltage and current PWM controllers can be as simple as those employed in [18], or be improved further to better deal with voltage and current imbalance and harmonics [23]–[28]. First, the simplified Clark transformation is applied to the measured variables. As example of this transformation, the grid voltage in the $\alpha\beta$ -reference frame can be calculated as

$$\begin{bmatrix} V_{A_alpha} \\ V_{A_beta} \end{bmatrix} = \begin{bmatrix} 1 & 1/2 \\ 0 & \sqrt{3}/2 \end{bmatrix} \begin{bmatrix} V_{A_ab} \\ V_{A_bc} \end{bmatrix}. \quad (1)$$

The shunt converter imposes the voltage at bus B. Thus, it is necessary to synthesize sinusoidal voltages with nominal amplitude and frequency. Consequently, the signals sent to the PWM controller are the phase-locked loop (PLL) outputs with amplitude equal to 1 p.u. There are many possible PLL algorithms.

In the original iUPQC approach as presented in [14], the shunt-converter voltage reference can be either the PLL outputs or the fundamental positive-sequence component V_{A+1} of the grid voltage. The use of V_{A+1} in the controller is useful to minimize the circulating power through the series and shunt converters, under normal operation, while the amplitude of the grid voltage is within an acceptable range of magnitude. However, this is not the case here, in the modified iUPQC controller, since now the grid voltage will be also regulated by the modified iUPQC.

In other words, both buses will be regulated independently to track their reference values. The series converter synthesizes the current drawn from the grid bus (bus A). In the original approach of iUPQC, this current is calculated through the average active power required by the loads PL plus the power P_{Loss} .

The load active power can be estimated by

$$P_L = V_{+1_alpha} \cdot i_{L_alpha} + V_{+1_beta} \cdot i_{L_beta} \quad (2)$$

where i_{L_alpha} , i_{L_beta} are the load currents, and V_{+1_alpha} , V_{+1_beta} are the voltage references for the shunt converter. A low-pass filter is used to obtain the average active power (PL). The losses in the power

converters and the circulating power to provide energy balance inside the iUPQC are calculated indirectly from the measurement of the dc-link voltage. In other words, the power signal P_{Loss} is determined by a proportional integral (PI) controller, by comparing the measured dc voltage V_{DC} with its reference value. The additional control loop to provide voltage regulation like a STATCOM at the grid bus is represented by the control signal $Q_{STATCOM}$. This control signal is obtained through a PI controller, in which the input variable is the error between the reference value and the actual aggregate voltage of the grid bus, given in equation 3.

The sum of the power signals P_L and P_{Loss} composes the active-power control variable for the series converter of the iUPQC (p) described in Section II. Likewise, $Q_{STATCOM}$ is the reactive-power control variable q .

$$V_{col} = \sqrt{V_{A+1_α}^2 + V_{A+1_β}^2} \tag{3}$$

Thus, the current references $i_{+1α}$ and $i_{+1β}$ of the series converter are determined by

$$\begin{bmatrix} i_{+1_α} \\ i_{+1_β} \end{bmatrix} = \frac{1}{V_{A+1_α}^2 + V_{A+1_β}^2} \begin{bmatrix} V_{A+1_α} & V_{A+1_β} \\ V_{A+1_β} & -V_{A+1_α} \end{bmatrix} \times \begin{bmatrix} \bar{P}_L + \bar{P}_{Loss} \\ \bar{Q}_{STATCOM} \end{bmatrix} \tag{4}$$

5.2.2. Power Flow in Steady State

The following procedure, based on the average power flow, is useful for estimating the power ratings of the iUPQC converters. For combined series–shunt power conditioners, such as the UPQC and the iUPQC, only the voltage sag/swell disturbance and the power factor (PF) compensation of the load produce a circulating

average power through the power conditioners the compensation of a voltage sag/swell disturbance at bus B causes a positive sequence voltage at the coupling transformer ($V_{series} = 0$), since $V_A = V_B$. Moreover, V_{series} and i_{PB} in the coupling transformer leads to a circulating active power P_{inner} in the iUPQC. Additionally, the compensation of the load PF increases the current supplied by the shunt converter. This is valid for an iUPQC acting like a conventional UPQC or including the extra compensation like a STATCOM., the circulating power will be calculated when the iUPQC is operating just like a conventional UPQC. Afterward, the equations will include the STATCOM functionality to the grid bus A. In both cases, it will be assumed that the iUPQC controller is able to force the shunt converter of the iUPQC to generate fundamental voltage always in phase with the grid voltage at bus A. For simplicity, the losses in the iUPQC will be neglected.

6. MATLAB/ SIMULATION RESULTS

Matlab/simulink diagram of modified IUPQC

Fig 6.1 Simulink model of modified IUPQC

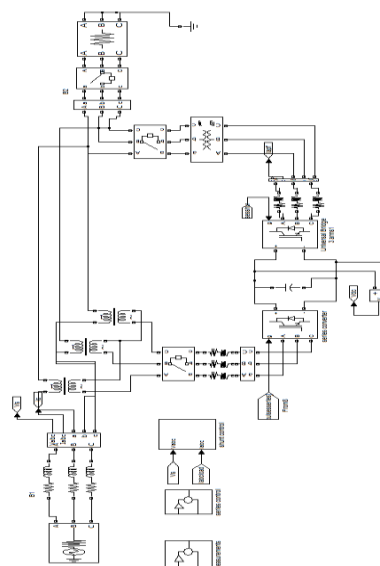

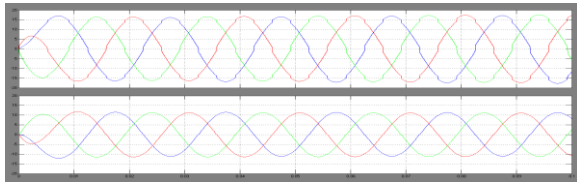

(a)

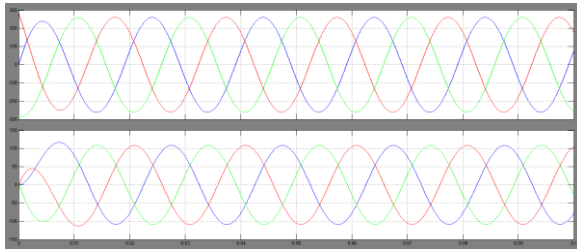

(b)

Fig 6.2 iUPQC response at no load condition:
(a)Load current and compensated current
(b)Grid voltages and currents

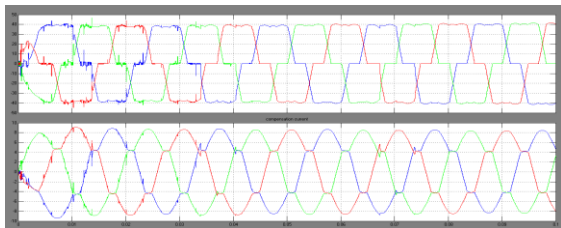

(a)

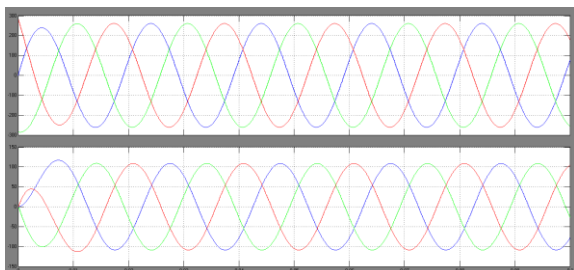

(b)

Fig 6.3 iUPQC transitory response during the connection of a three phase diode rectifier:

(a)Load current and compensated current
(b)Grid voltages and currents.

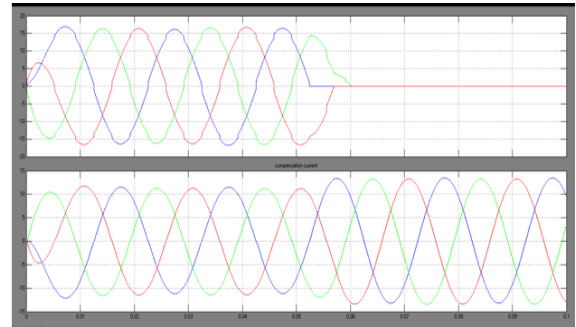

(a)

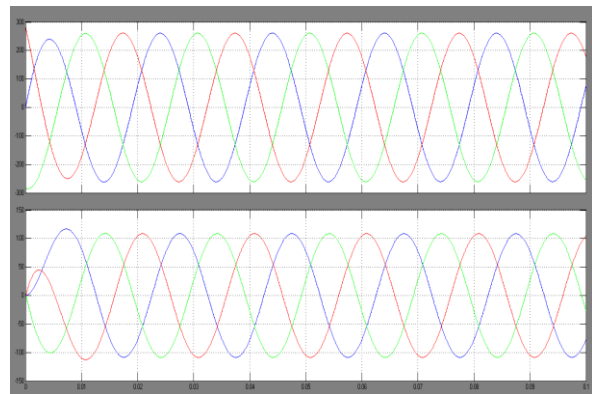

(b)

Fig. 6.4.iUPQC transitory response during the connection of a two phase diode rectifier: (a)Load current and compensated current (b)Grid voltages and currents.

CONCLUSION

In the upgraded iUPQC controller, the currents synthesized by the series converter are determined by the load's average active power, the active power to provide dc-link voltage regulation, and the average reactive power to regulate the grid-bus voltage. In this way, in addition to all of the power-quality adjustment features of a traditional UPQC or an iUPQC,

This upgraded controller functions as a STATCOM on the grid bus. This new feature

broadens the iUPQC's applicability and introduces new solutions for future scenarios including smart grids and microgrids, such as distributed generation and energy storage systems, to better deal with the inherent fluctuation of renewable resources like solar and wind. Furthermore, the upgraded iUPQC controller may justify the expenses and promote the iUPQC's applicability in power quality issues of critical systems, where both an iUPQC and a STATCOM are required at the same time. Despite the addition of one more power-quality compensation feature, grid-voltage regulation reduces inner-loop circulating power within the iUPQC, allowing the series converter to have a lower power rating.

The simulation findings confirmed the revised iUPQC targets. The grid voltage was regulated both with no load and with a three-phase nonlinear load.

These results show that voltage control works well on both sides of the iUPQC, even when adjusting for harmonic current and voltage imbalances.

REFERENCES

- [1] K. Karanki, G. Geddada, M. K. Mishra, and B. K. Kumar, "A modified three-phase four-wire UPQC topology with reduced DC-link voltage rating," *IEEE Trans. Ind. Electron.*, vol. 60, no. 9, pp. 3555–3566, Sep. 2013.
- [2] V. Khadkikar and A. Chandra, "A new control philosophy for a unified power quality conditioner (UPQC) to coordinate load-reactive power demand between shunt and series inverters," *IEEE Trans. Power Del.*, vol. 23, no. 4, pp. 2522–2534, Oct. 2008.
- [3] K. H. Kwan, P. L. So, and Y. C. Chu, "An output regulation-based unified power quality conditioner with Kalman filters," *IEEE Trans. Ind. Electron.*, vol. 59, no. 11, pp. 4248–4262, Nov. 2012.
- [4] A. Mokhtatpour and H. A. Shayan far, "Power quality compensation as well as power flow control using of unified power quality conditioner," in *Proc. APPEEC*, 2011, pp. 1–4.
- [5] J. A. Munoz et al., "Design of a discrete-time linear control strategy for a multicell UPQC," *IEEE Trans. Ind. Electron.*, vol. 59, no. 10, pp. 3797–3807, Oct. 2012.
- [6] V. Khadkikar and A. Chandra, "UPQC-S: A novel concept of simultaneous voltage sag/swell and load reactive power compensations utilizing series inverter of UPQC," *IEEE Trans. Power Electron.*, vol. 26, no. 9, pp. 2414–2425, Sep. 2011.
- [7] V. Khadkikar, "Enhancing electric power quality using UPQC: A comprehensive overview," *IEEE Trans. Power Electron.*, vol. 27, no. 5, pp. 2284–2297, May 2012.
- [8] L. G. B. Rolim, "Custom power interfaces for renewable energy sources," in *Proc. IEEE ISIE*, 2007, pp. 2673–2678.
- [9] N. Voraphonpipit and S. Chatratana, "STATCOM analysis and controller design for power system voltage regulation," in *Proc. IEEE/PESTransmiss. Distrib. Conf. Exhib.—Asia Pac.*, 2005, pp. 1–6.
- [10] J. J. Sanchez-Gasca, N. W. Miller, E. V. Larsen, A. Edris, and D. A. Bradshaw, "Potential benefits of STATCOM application to improve generation station performance," in *Proc. IEEE/PES Transmiss. Distrib. Conf. Expo.*, 2001, vol. 2, pp. 1123–1128.
- [11] A. P. Jayam, N. K. Ardesna, and B. H. Chowdhury, "Application of STATCOM for improved reliability of power grid containing a wind turbine," in *Proc. IEEE*.