

DETECTION OF LPG LEAKAGE USING

ARDUINO UNO

Deepak Kumar¹, Adarsh Paswan², Krishn Murari³, Abhishek⁴

Department of Electronics and Communication Engineering^{1,2,3,4}

*Buddha Institute Of Technology ,Gida ,Gorakhpur U.P.,273209
Dr. A.P.J. Abdul Kalam Technical University Lucknow U.P., 226031*

ABSTRACT

*This project provides a new approach to detect LPG Leakage based on microcontroller Based on Arduino. And using GSM Module for SMS Alert on Liquefied petroleum Gas Leakage and Preventing any unwanted incident ,we should apply some safety measure to detect the leakage .We have developed on Arduino based LPG gas detector alarm. If gas leakage occurs, these systems detect it. The LPG sensor mq6 is on accurate LPG sensing device which acquires the signal intensity. An efficient Arduino based signal processing mechanism is followed which effectively quantizes the acquired electrical signal .The intensity of the LPG leakage is classified in three classes depending on the quantized values acquired from the LPG sensor .The three classes are Low, Medium he and High. When arduino gets a high pulse from LPG cylinder or pipeline it shows "High" message on 16*2 Liquid crystal display (LCD) and activates a buzzer which beeps on a lower frequency until the gas detector module doesn't sense the "Low-leakage" state. For a medium range leakage, it shows "Medium" in the display and beeps on a lower frequency. When LPG leakage is not dangerous, a "Low" message is displayed.*

Keywords: - Arduino Uno, Mq6 gas sensor, GSM module, Buzzer, wires, Dot PCB.

1. INTRODUCTION

In our country generally over 80% LPG customers in which generally 35% of the gas related accidents occur because of gas leakage. Gas leakage may leads to severe accidents which results in material losses and human injuries. Gas leakage occurs mainly due to poor maintenance of equipments and inadequate awareness of the people. Hence LPG leakage detection will be helpful to prevent accidents and to save human lives. The Gas Leak identifier gadget can discover application at private homes as well as it is relevant to inns, eateries and even in businesses where LPG gas is utilized for a few or alternate purposes. This system is very simple yet reliable. Many factors can cause leakage of LPG gas cylinders, including improper installation of regulators, poor quality seal rings, non-tested Indonesian National Standard (SNI) regulators, gas hose tearing caused by animals such as rats, as well as the quality of the LPG cylinder itself which can unwittingly cause a gas leak. Given the considerable losses that can be caused from LPG gas leakage, the authors are interested in

creating a system of "Early Warning LPG Gas Leaks Through Short Message Service (SMS) and Loudspeakers (Speakers) Using Arduino Uno".

2. LITERATURE REVIEW

In [4] authors introduced GSM based gas leakage detection system, in which the GSM module is introduced for wireless alert and gas leakage detection, efficiently implemented.

In [5] authors proposed WSN based smart system for detection of LPG and combustible gases, works in flexible ways of smart detecting of gases on recent techniques.

In [6] authors presented embedded system for hazardous gas detection and alerting, comprises entire hardware into single embedded board for ease, low cost and sustainable.

In [7] it describes the performance and functional characteristics of ARM based sensor. Developed to monitor changes in CO₂, temperature, alert in remote location.

In [8] PIC18LF4620 based wireless sensor node, monitor the parameter humidity, light, oxygen around the pipeline.

Although Detection is a process to check or examine something using certain methods and techniques.

The purpose of detection is to solve a problem by speaking depending on the method applied so as to produce a solution. LPG (Liquefied Petroleum Gas) LPG gas is a gas fuel obtained from the high

pressure distillation process. [3] The fraction used as bait can come from several sources, namely from natural gas and gas from the processing of petroleum (Light End). Liquefied Petroleum Gas (LPG)

consists of carbon and hydrogen elements which are hydrocarbon compounds with the main components C₃ and C₄. The LPG composition consists of propane (C₃H₈), propylene or propane (C₃H₆),

butane (C₄H₁₀), butane (C₄H₈), and small amounts of ethane (C₂H₆), ethylene (C₂H₄), and pentane (C₅H₁₂)

The nature of LPG is mainly as follows:

1. The liquid and gas are very flammable
2. Gas is non-toxic, colorless and usually has a strong odor
3. Gas is sent as a liquid
4. Liquids can evaporate if released and spread quickly.
5. LPG gas is heavier than air so it will occupy a lot of low areas.

2. METHODOLOGY

This project fundamentally manages the advancement of a straightforward gas spill locator at the underlying stage and after that changing this basic gadget into a most progressive gas identifier framework later on.

In view of this paper it can be described how the tool can work to capture the gas received by the sensor, then the sensor is processed in an Arduino program that can display data in the LCD, emit sound and send a short message to the registered mobile number. The scheme can be seen in the block diagram which is shown in figure no 1. When a sudden leakage happens, the gas sensor sends a signal to the microcontroller. The controllers processes a signal and send notification to other external devices attached such as LCD, buzzer and an GSM module which previously stored phone numbers of the persons that are responsible on fighting fires in

the hospital, this alarm will send it repeatedly until an accepting reply message received. A smart system will contain necessary sensors for detecting gas leakage. It scans for gas leakage and show the result in the LCD. When the sensors find any gas leakage in a room or where the devices are installed, it immediately sends a notification by GSM network, there will be an automatic messaging generating operation. The gas sensors keep on scanning for gas, it detects the leak depending on the predefine threshold. The system works independently on human enters, also it works dependably by the human or the responsible operator presses push button switch, when any leak occurs. The block diagram of whole system is shown bellow in Figure 1. A smart system will contain necessary sensors for detecting gas leakage. It scans for gas leakage and show the result in the LCD. When the sensors find any gas leakage in a room or where the devices are installed, it immediately sends a notification by GSM network, there will be an automatic messaging generating operation. The gas sensors keep on scanning for gas, it detects the leak depending on the predefine threshold. The system works independently on human enters, also it works dependably by the human or the responsible operator presses push button switch, when any leak occurs. The block diagram of whole system is shown below in Figure 1.

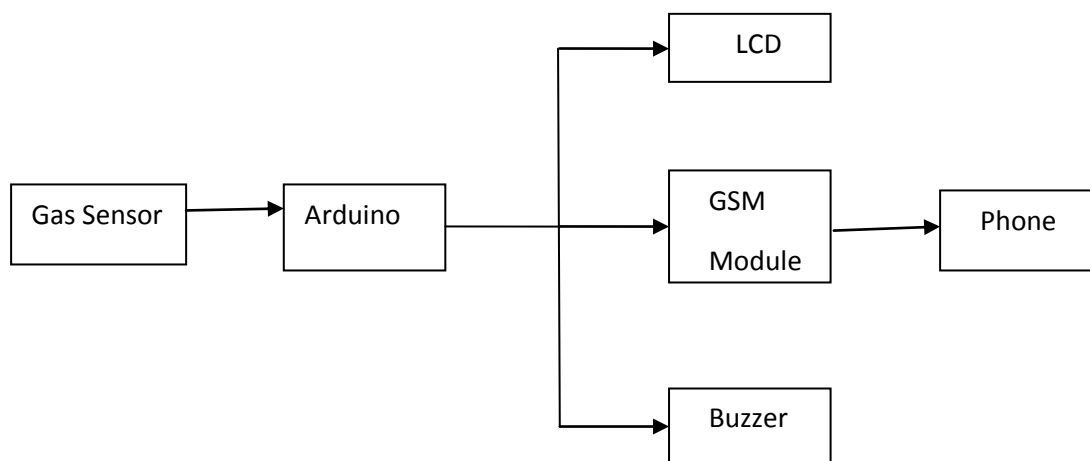

Figure 1- Block Diagram

Each of components/devices are shown below, which is shown in the block diagram (fig. 1).

2.1- Microcontroller, Microcontroller is widely available in all-electronic equipment, fax machines, and other electronic equipment. The microcontroller can also be called a small computer that is low-power so that a battery can provide power is an open-source single-board micro controller, derived from the Wiring platform, designed to facilitate the use of electronics in various fields. The hardware has the Atmel AVR processor and the software has its own programming language. Arduino UNO is a microcontroller board based on ATmega328 . Arduino is shown in figure no 2.



Figure 2- Arduino UNO

2.2- The MQ 6 sensor is a gas sensor that is suitable for detecting LPG (Liquefied Petroleum Gas), can detect LPG gas and includes gases consisting of LPG gas namely propane and butane gas. This sensor can detect gases at concentrations in the air between 200 to 10000 ppm. This sensor has high sensitivity and fast response time. The sensor output is analog resistance. The circuit of this sensor is very simple, what this sensor needs is to provide a voltage of 5 V, add load resistance, and connect the output to the ADC. MQ6 sensor is shown in figure no3.



Figure 3-MQ 6 Sensor

2.3- GSM module Shield is an additional component that allows Arduino to connect to the GSM network, send and receive voice, text and GPRS services. This component uses digital pins 2 and 3 for serial communication with the Arduino board and uses the M10 Quad-band GSM / GPRS radio modem from Quectel that supports 4 GSM 850MHz frequencies, GSM 900MHz, DCS 1800 MHz and PCS 1900MHz. With a maximum speed of GPRS data transfer 85.6 kbps. GSM Module is shown in figure no 4.



Figure 4-SIM800L GSM Module [2]

2.4- Buzzer is an electronic component that functions to convert electrical vibrations into sound vibrations. The working principle of the buzzer is almost the same as the loudspeaker. A buzzer consists of a coil mounted on a diaphragm and flowed so that it becomes an electromagnet. The coil will be pulled in or out depending on the current direction and magnetic polarity. Because the coil is mounted on the diaphragm,

each movement of the coil will move the diaphragm back and forth so that it makes the air vibrate and produce sound. Buzzer is shown in figure no 5.



Figure 5-Buzzer

2.5- LCD (Liquid Crystal Display) is a media that uses liquid crystal as the main viewer. LCD has been used in various fields such as electronic devices such as televisions, calculators or computer screens. LCD functions to display writing in the form of numbers or letters in accordance with the wishes based on the program used, so that the display can be seen visually. LCD (Liquid Crystal Display) is shown in figure no 5.



Figure 6-16X2 LCD

3. APPLICATIONS

Safety plays a major role in today's world and it is necessary that good safety systems are to be implemented in places of education and work. The LPG or propane which is flammable mixture of hydrocarbon gases used in use as fuel in much application like homes, hostels, industries, automobiles' vehicles because of its desirable properties which include high calorific value, which produce the less smoke, produces less soot and does not cause much harm to the environment. Natural gas is another widely used fuel in homes. Both cases burns to produce clean energy, however there is a serious problem about their leakage in the air. The gases being heavier than air do not disperse easily and may lead to suffocation when inhaled also when gas leakage into the air may lead to explosion' Due to the explosion of LPG gas the no of deaths has been increased in recent years. So this device can be used.

- The gas detection an alter system that we have designed is a very cost effective system to detect leakage of any gas. It not only detects leakage of gas it also alerts us by producing sounds like alarm etc. It has its applications in various fields like school, colleges, universities, homes and industries.
- It is especially useful in the case when leakage takes place when there is no one around, in this case the MQ6 gas sensor detects the leakage and the system alerts by producing a sound' With this system in

place not only would a timely alert been useful for evacuation but the source of gas leakage could also have been stopped and a lot of lives would have been saved.

4. Flow chart

Flowchart is a graphical development of the steps and sequence of procedures of a program. Flowcharts help programmers to solve problems in smaller segments and help in analyzing other alternatives in operation.

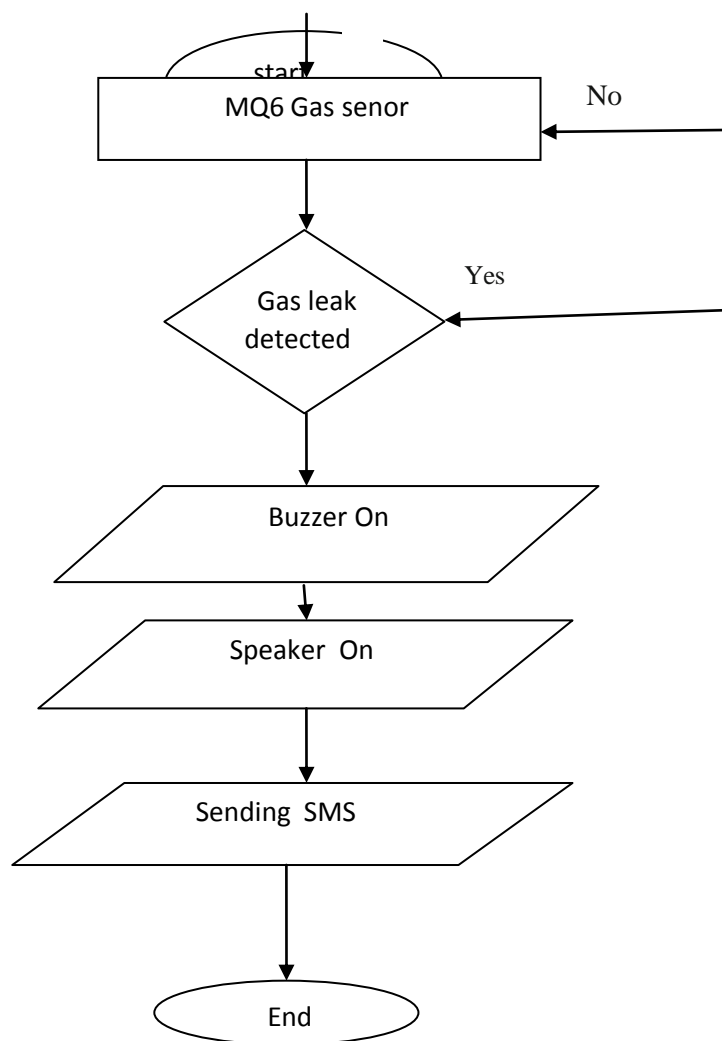

Figure -7: Flow Chart of project [1]

From the picture above it can be seen that this tool has an input device (input device) consisting of a gas sensor and an output device (output device) which consists of an LCD, GSM Module, and buzzer. The way this tool works is when it is turned on, the sensor will work to transfer LPG gas and send data

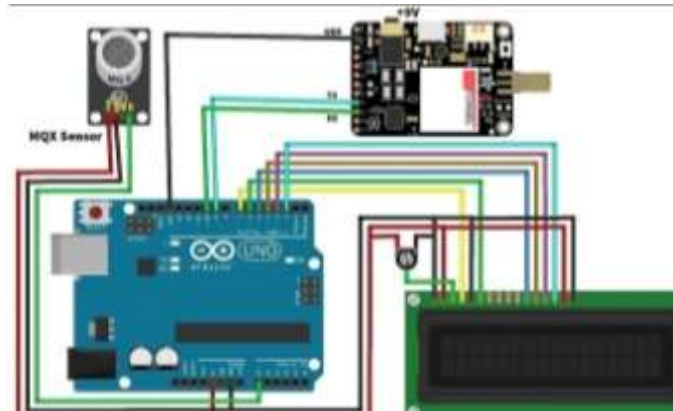

Figure 8-Circuit Diagram of Project

At the stage of making this circuit, what is done is to prepare components that will be used, such as the mq-6 sensor, Arduino Uno, relay, adapter, power / battery, GSM SIM800L, buzzer, ISD1820 module, speaker and jumper cable. The arduino Uno has an Atmega 328 microcontroller, which has 14 digital input / output pins (6 outputs for PWM), and 6 analog input pins. Arduino electronic circuits have several other components such as IC regulators that function as the power supply circuit needs. The Circuit is shown in figure 8.

5. Conclusion

Based on the whole system starting from the design and manufacture of tools that have been done, the author has several conclusions including :

1. .Sensor testing is carried out in three different places, namely ventilated space, airtight space, and open space. In the test room ventilated results of the detected gas content between 54 - 126 ppm, in the airtight room the detected results were between 40 -457 ppm, and in the open room the detected results were only 6 ppm.
2. .Distance testing of the MQ-6 sensor is performed at a distance of 2 cm, 4 cm, 6 cm, 8 cm and 10 cm. It was also carried out in three different places, from the test the ideal distance for detection is at a distance of 2 to 6 cm in a ventilated and airtight room. Then other factors that influence censorship are wind factors such as testing in open spaces, if the wind blows hard enough then the detected gas levels will decrease / not be detected.
3. SMS testing is also carried out in three different places, namely ventilated space with sensor response time between 3 to 8 seconds and SMS sending time between 8 to 26 seconds, airtight space with sensor response time 3 to 12 seconds and SMS sending time between 16 to 182

seconds, while in the open space the sensor response time is only 13 seconds and no texting is detected because there are no leaks with amounts of gas above 100 ppm.

REFERENCES

Journal Papers:-

- [1] CI Parwati, H P Suseno, E Fatkhiyah, 2015, Modeling telemetry system”Multi-Node” early warning ammonia gas leak based SMS gateway, Jurnal Teknologi volume 8 number 2, December 2015.
- [2] Rahayu, N. (2020). Early Warning Of Leaking Lpg Gas Through Short Message Service (Sms) And Loudspeaker Tool Using Arduino Uno. *Journal of Applied Engineering and Technological Science (JAETS)*, 1(2), 91-102. <https://doi.org/10.37385/jaets.v1i2.61>.
- [3] Muhammad Siddik Hasibuan, Syafriwel and Iswandi Idris “Intelligent Gas Leak Detection Tool with SMS Notification “Published under licence by IOP Publishing Ltd Journal of Physics: Conference Series, Volume 1424, 2nd International Conference on Advance & Scientific Innovation 19–20 July 2019, Medan, Indonesia.
- [4] Shrivastava, A., Prabhaker, R., Kumar, R., & Verma, R. GSM based gas leakage detection system. *International Journal of Emerging Trends in Electrical and Electronics (IJETEE-ISSN: 2320-9569)*, 2013; 3(2):42-45.
- [5] Hema, L. K., Murugan, D., & Chitra, M. WSN based Smart system for detection of LPG and Combustible gases. In *National Conf. on Architecture, Software systems and Green computing-2013*.
- [6] Ramya, V., & Palaniappan, B. Embedded system for Hazardous Gas detection and Alerting. *International Journal of Distributed and Parallel Systems (IJDPS)*, 2012; 3(3):287-300.
- [7] Priya, P. D., & Rao, C. T. Hazardous Gas Pipeline Leakage Detection Based on Wireless Technology. *International Journal of Professional Engineering Studies, India*, 2014; 2(1).
- [8] Jero, S. E., & Ganesh, A. B. 2011, March. PIC18LF4620 based customizable wireless sensor node to detect hazardous gas pipeline leakage. In *2011 International Conference on Emerging Trends in Electrical and Computer Technology* (pp. 563-566). IEEE.