

# STUDY OF PICK AND PLACE MECHANISM FOR INNER TUBE OF SHOCK ABSORBER

HimanshuPatil<sup>1</sup>, Digambar Shinde<sup>2</sup>, Kanak Marde<sup>3</sup>, Mahendra Ahire<sup>4</sup>,  
Firoj Pathan<sup>5</sup>

<sup>1,2,3,4</sup> B.E.Mechanical Scholar BVCOE&RI Nashik,

<sup>5</sup> Assistant Professor Mechanical Dept. BVCOE&RI Nashik (India)

## ABSTRACT

In the most demanding P&P applications, robot need computer vision to recognize product shape and orientation, and also need conveyor tracking systems in order to allow manipulation during product motion on the conveyor track. phases: i) gripping, grasp or start of contact; ii) positioning, the object is moved from one point to another with a movement defined by three Cartesian axes; iii) orienting, object is orientated by three rotations related to Cartesian axes; and iv) placing, release or loss of the contact . Use of robotic automation in manufacturing industries has increased tremendously. In this research work, select kinematic configuration of robot and vacuum cup to handling object for pick and place application, how to Evaluate D-H parameter, forward and inverse kinematics equations and work volume . Kinematic analysis of robot and selection of vacuum cup for varied weight of object during pick and place application and dynamic analysis of it. .The process of production of inner tube of length 520 mm &time required for picking and dimension checking of tube (cell) is near about the 17 to 18 seconds. Initially the machine was designed for 520 mm Yamaha and Bajaj model tubes. Whereas the machine is now to be used for 320 mm Mahindra Rodeo and Duro model tubes. So at the time of dimension checking two tubes of 320 mm were coming on the conveyor in the same time interval. It was not possible to pick and place two tubes at the same time by single arm , as a result one tube was picked up manually.To encounter this problem, we designed the mechanism with two arms. Where when one arm picks up the tube, the second arm places the tube on the gauge for calibration. As a result, the cycle time reduces from 18 sec to 8 sec.

**Keywords:-**Inner tube of shock absorber ,vacuum cup, grippers, laser.

## I. INTRODUCTION

Now a days trend of automation so that in industrial application robots are used to complete different task like material handling , welding ,spray painting ,assembly and in medical application for surgery.Pick and place application is one of the common application of all type of industries such as during machine loading and unloading task.The machine which is presently use includes an individual device for picking and placing tube on gauge tester which takes more time and dial gauge are use for checking outer diameter of tube. The cylinder travels on full slide which also time taking and sorting of tubes done manuallypick and place mechanism was developed for inner tube of bike of 520 mm length it comes from conveyor up to the pick and place mechanism conveyor speed is fixed there is only one tube come at a time and cycle time for picking and calibration of single

tube was 32 sec. The main problem raised when manufacturing of inner tube of 320 mm in length because of its short length compared to 520mm two tubes come at a time because of prefixed conveyor speed. This causes introduction of manual work in mechanism one tube was picked by worker and calibrated and second tube directly goes without calibration.

## II. INTRODUCTION TO SHOCK ABSORBERS

A shock absorber is a mechanical device designed to smooth out or dampshock impulse, and dissipate kinetic energy. Other names for a shock absorber include damper and dashpot. The automotive suspension component is often called just shock. Pneumatic and hydraulic shock absorbers are used in conjunction with cushions and springs. An automobile shock absorber contains spring-loaded check valves and orifices to control the flow of oil through an internal piston. The shock absorber absorbs and dissipates energy. In hydraulic cylinders, the hydraulic fluid heats up, while in air cylinders, the hot air is usually exhausted to the atmosphere. In a vehicle, shock absorbers reduce the effect of traveling over rough ground, leading to improved ride quality and increase in comfort. While shock absorbers serve the purpose of limiting excessive suspension movement, their intended sole purpose is to dampen spring oscillations. Shock absorbers use valving of oil and gases to absorb excess energy from the springs. Spring rates are chosen by the manufacturer based on the weight of the vehicle, loaded and unloaded.

## III. PRESENT THEORY AND PRACTICES

The phrase “handling technology” is derived from the word “hand” – and as we all know, the human hand is capable of a very great number of things. If we attempt within the context of industrial production to replace the human hand with technical devices, we expect first and foremost movements which are fast, repeatable and accurate. Flexibility is a quite separate matter. For tasks such as sealing bottles or assembling ballpoint pens, for example, flexibility is not required.

Tasks of this kind are the territory of pick-and-place devices. The main application of these devices is work piece handling in component manufacture and assembly, rather than the handling of tools. Despite the fact that programmable robots are now commonplace in production operations, with numbers growing day by day, these have in no way taken the place of pick-and-place devices. In terms of units, there are still more pick-and-place devices sold than robots. The simple reason for this is that, today and in the future, there are and will still be many handling operations for which programmable handling devices are clearly over-qualified.

### 3.1. Operation Sequence:-

We have designed pick and place mechanism with two grippers which can pick two tubes coming from conveyor at a time.

1. Tube comes from conveyor up to the pick and place mechanism.
2. It is picked and tested in laser gauge.
3. The tube travels 500 mm.
4. When first tube travels up to the go gauge and no go gauge second tube is picked.
5. At the same time first tube is tested by laser gauge and second is tested in go

Gauge and no go gauge.

6. Tubes in tolerance and beyond tolerance are separated at this stage.

7. In this way cycle continues and 100% calibration is done.

## IV. WORKING PRINCIPLE AND COMPONENT DETAILS

### 4.1. Components details:

#### Motor:

The three-phase induction motors are the most widely used electric motors in industry. They run at essentially constant speed from no-load to full-load. However, the speed is frequency dependent and consequently these motors are not easily adapted to speed control. We usually prefer d.c. motors when large speed variations are required. Nevertheless, the 3-phase induction motors are simple, rugged, low-priced, easy to maintain and can be manufactured with characteristics to suit most industrial requirements. It has simple and rugged construction. It is relatively cheap. It requires little maintenance. It has high efficiency and reasonably good power factor. It has self-starting torque.

#### 4.2. Lead screw:

A lead screw also known as a powerscrew or translationscrew is a screw designed to translate turning motion into linear motion. Common applications are Linear actuators, machine slides (such as in machine tools), vices, presses, and jacks. Lead screws are manufactured in the same way as other thread forms. A lead screw can be used in conjunction with a split nut.

#### 4.3. Jaws (Grippers):

Motion devices mimic the movements of people, in the case of the gripper, it is the fingers. A gripper is a device that holds an object so it can be manipulated. It has the ability to hold and release an object while some action is being performed. The fingers are not part of the gripper, they are specialized custom tooling used to grip the object and are referred to as "jaws."

#### 4.4. Operation of Jaws:

The most widely used gripper is the pneumatically powered gripper; it is basically a cylinder that operates on compressed air. When the air is supplied, the gripper jaws will close on an object and firmly hold the object while some operation is performed, and when the air direction is changed, the gripper will release the object. Typical uses are to change orientation or to move an object as in a pick-n-place operation.

#### 4.5. Gripping Action:

##### External:

This is the most popular method of holding objects, it is the most simplistic and it requires the shortest stroke length. When the gripper jaws close, the closing force of the gripper holds that object.

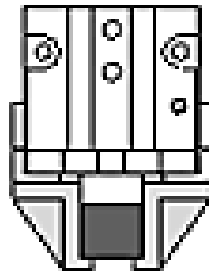

Fig3.1 : External Gripper (Closed)

## V. TYPES OF PNEUMATIC GRIPPERS

The most popular types of pneumatic grippers are the 2 jaw parallel and 2 jaw angular gripper styles. Parallel grippers open and close parallel to the object that it will be holding, these are the most widely used grippers. They are the simplest to tool and can compensate for some dimensional variation. Angular grippers move the jaws in a radial manner to rotate the jaws away from the object and therefore require more space.

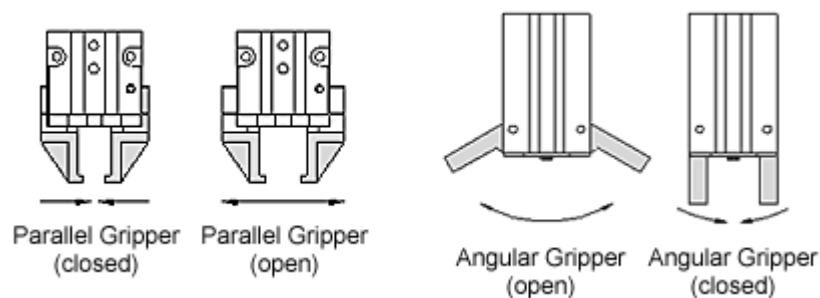

Fig 3.2 Parallel Gripper and Angular Gripper

There are also 3 jaw and toggle style grippers that are designs for more specific handling requirements.

### 5.1. Trays:

Trays are used to collect tubes after calibration. The tubes in calibration limit are collected in one tray and the rejected tubes are collected in other one.

### 5.2. Base:

Base plate supports the whole assembly of machine. It is attached to the Base plate supports the whole assembly of machine. It is attached to the frame/structure.

### 5.3. Structure:

It supports the whole machine and all its parts. The material used is mild steel. Structure also holds all the other components in place so as they function properly.

## VI. DESIGN PROCEDURE

Design process adopted for the pick and place mechanism machine is given below. The Fig shows 2D representation of the pick and place mechanism machine

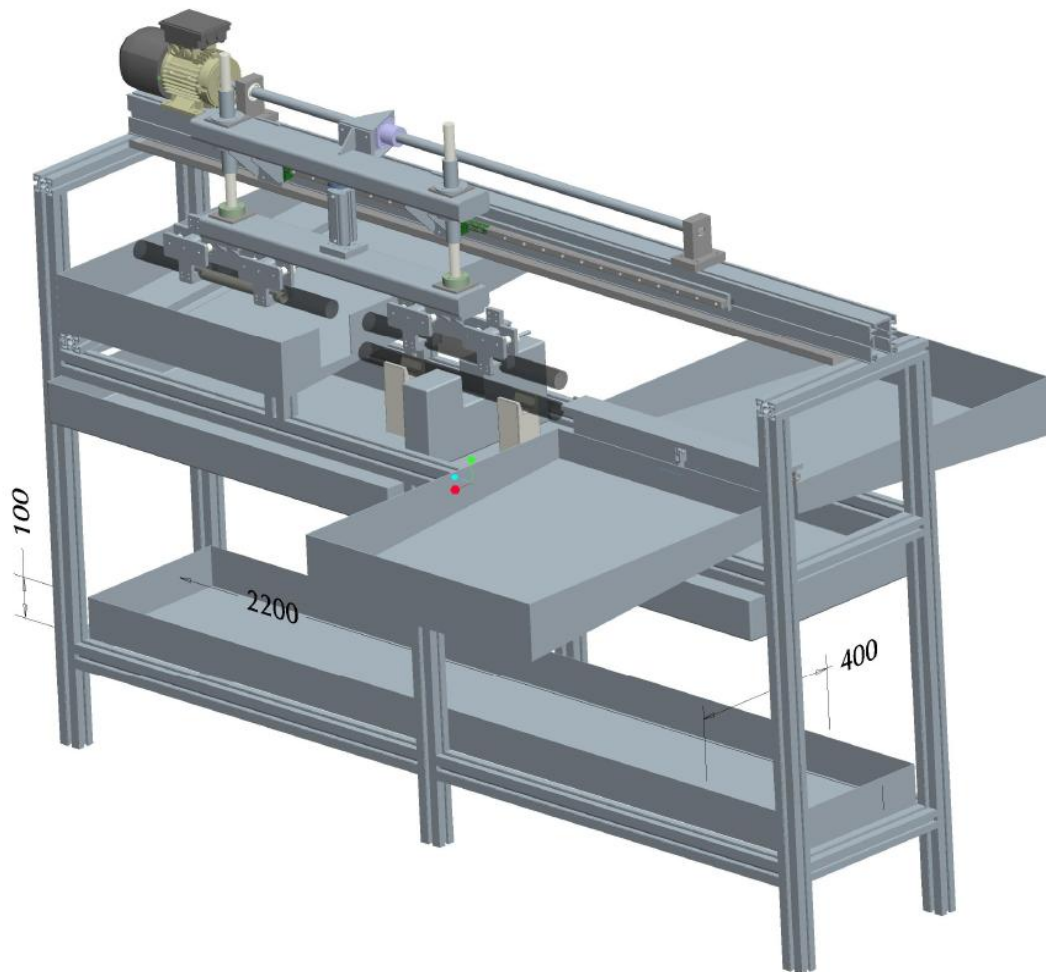

### **3D Representation of Pick and Place mechanism**

#### **6.1. Design Parameters**

Different parameters are considered for design which includes mainly stresses induced, applied torque, weight of different components, factor of safety and space limitations.

#### **6.2. Design of Machine Parts:**

Design and dimensions of all the components of the twin pick and place mechanism is given below. The properties of materials used are also stated in below sections.

### **VII. SENSOR**

#### **7.1. Beta laser mike:**

We live in a world where increasingly tighter tolerances are a way of life - and so is the pressure to turn out precision parts efficiently. That's why you can't compromise on the accuracy of your measurement systems - which is precisely why we don't compromise on our measurement solutions.

Beta Laser Mike's off-line dimensional measurement gauges give you the absolute truth about your parts. And because nothing but laser light touches your product, there's no part distortion or operator influence to affect your measurements. You can measure soft, delicate, brittle, hot, even radioactive parts with complete confidence.

Beta Laser Mike's off-line dimensional measurement gauges give you the absolute truth about your parts. And because nothing but laser light touches your product, there's no part distortion or operator influence to affect your measurements. You can measure soft, delicate, brittle, hot, even radioactive parts with complete confidence.

- Outer Diameter
- Multiple ODs
- Taper
- Straightness
- Part Position
- Height
- Width
- Gap Between Parts

Beta Laser Mike is the premier developer of laser based micrometer measuring systems. Beta's products range from the popular ZMike and Bench Mike products for measuring parts and certifying gages to the on-line production environment solutions like the AccuScan and Center Scan.

Beta Laser Mike offers custom measuring solutions for your production process. Whatever your process; rolling, extruding or forming, and whatever your product; wire, cable, fiber optics, pipe, tube, hose, bars, rods, shafts, dowels and whatever your material; metal, synthetics, rubber, wood, Beta Laser Mike has a solution that works. And it can be configured to work in extreme environmental conditions. Several options are available for data Input/output handling.

With Beta Laser Mike you can reliably and quickly measure Outside Diameters, TIR, Taper, and Straightness, Position, Height, Width, Gap Spacing and more!

Specifications of BETALASERMIKE INC.:

Model: LD1040 S

Diameter Range: 25-45mm

Accuracy: 0.001 mm (+/- 0.02%)

Resolution: 0.001 mm

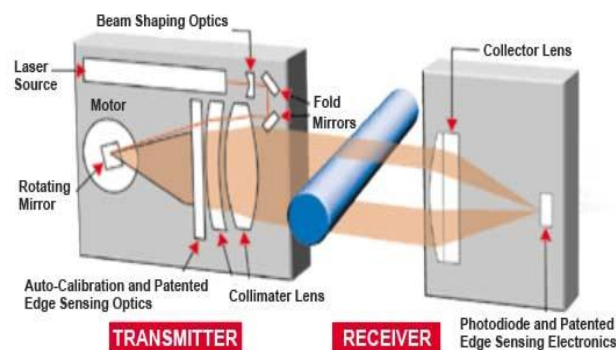

**Fig: Beta laser system**

**7.2. Get reliable measurements from run to run:**

Non-contact measurement technique provides the same level of accuracy, regardless of operator. Tolerance checking alerts operators of out-of-tolerance conditions. Mounting fixtures ensure the test piece is always properly presented to the gauge.

**VIII. COMPARISON OF OLD AND NEW MACHINE**

**8.1. On the basis of Average Rejection:**

On the old machine, the calibration was done manually. In the manual checking, The tubes were inserted manually. Because of this there was friction between tubes and gauge. As a result, dent marks were produced on the tube. Because of these dent marks the tubes were rejected in the market.

Whereas, in the new machine, the calibration is done by BETALASER MIKE.

Here there is absolutely no contact between the tubes and laser gauge. So the operation is clean and no dent marks are produced. As a result there is no rejection of tubes.

The following bar chart shows the 25 days average rejection level with old machine and new machine. With old machine average rejection is around 18 product per shift which is reduced to 2 product observed to be rejected in two shift with new machine.

**8.2. On the basis of Average Cycle time Reduction:**

On the old machine, only one tube was picked at a time, and then the calibration was done. The total time required for this cycle is 18 sec.

On the new machine, one tube was picked by one arm, and then it is placed on the gauge. Here the calibration is done. At this time, other tube is picked by second arm. So at a time, one tube is picked and the calibration of other tube is done. As a result the cycle time reduces.

In old machine for dimension checking 18 sec were required after installing new mechanism of pick and place, cycle time was reduced up to 7-8 sec

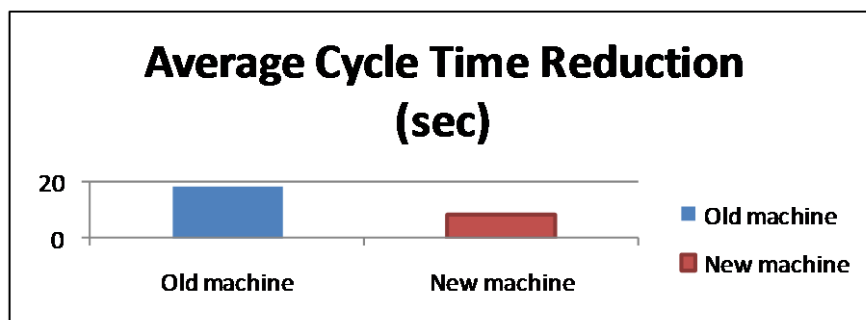

**8.3. On the basis of Average Productivity Results:**

On the old machine 2 workers were required for inspection and checking. But in the new machine only one worker is required only for observation and maintenance purpose.

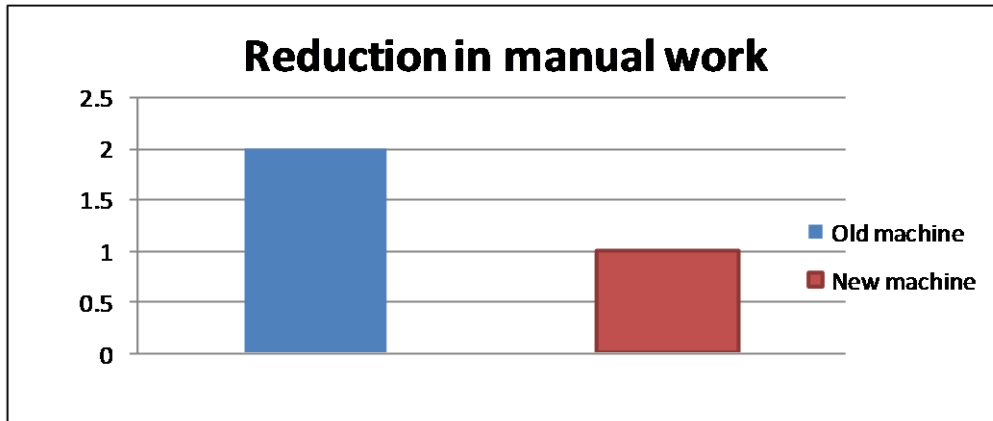

Reduction in manual work

#### 8.4. Effect on Cycle Time:

Cycle time is the time required for the completion of desired task. It will be calculated as the time between first finish product and the next to it.

During the older process due to single arm, the operation on one tube was done at a time. So due to this reason, the cycle time for the process is approximately 32 seconds i.e. each successive product comes out after every 32 seconds.

On the new machine, one tube was picked by one arm, and then it is placed on the gauge. Here the calibration is done. At this time, other tube is picked by second arm. So at a time, one tube is picked and the calibration of other tube is done. As a result the cycle time reduces.

In old machine for dimension checking 32 sec were required after installing new mechanism of pick and place, cycle time was reduced up to 18-19 sec.

Therefore,

$$\text{Percentage reduction in Cycle Time} = \frac{18-8}{18} \times 100 = 55.56 \%$$

### IX. CONCLUSION

The project has been developed so as to, reduce the rejection of tubes, to increase the productivity, to increase the accuracy of operation and also to reduce the man-power needed for the job. This will lead to rapid development of the industry.

The machine is an excellent way to initiate an employee development activity in the company. It increases the production rate and also does not threaten employment of the labor. Instead, it reduces production cost and the fatigue caused to the labor working repeatedly on this job. The project has been a great learning curve for us. We were well accustomed with the process of planning, designing, manufacturing and testing of a product.

To relate the results with the objective of this work following some important conclusion are drawn from the results and observations.

- The principle conclusion of this work is to improve the production rate in order to increase the productivity and to decrease the rejection level.

- The production rate of company with the use new pick and place mechanism has been increased by around 70%.
- The rejection level has been decreased by around 90% i.e. almost null rejection as compared to old single arm mechanism.

## REFERENCE

- [1] Willson M.,2010.development in robot applications for food manufacturing.Ind Robot 37,498-502.
- [2] Chanhun Park and KyoungtaikPark(2013), “Design and Kinematics Analysis of Dual Arm Robot Manipulator for Precision Assembly”IEEE ,p.p 431-435.
- [3] SanketkumarR.Patel M.E.(CAD-CAM) A.D.PATEL Institute of technology,NewV.V.Nagar,” A review on Design and analysis of pick and place robot using vaccum gripper”.
- [4] C. Blanes1\*, M. Mellado1, C. Ortiz2 and A. ValeraInstituto de Automática e Informática Industrial.
- [5] Departamento de Ingeniería Rural y Agroalimentaria. Universitat Politècnica de València.Camino de Vera s/n, 46022 Valencia. Spain” Review. Technologies for robot grippers in pick and place operations for fresh fruits and vegetables”.
- [6] Peter Tuleja, LuboslavaSidlovska (2014), “Unilateral gripping with active vacuum suction cup Calculation of gripping force and number of suction cups”.
- [7] John R. Amend, Jr., Eric M. Brown, Nicholas Rodenberg (2011), “A Positive Pressure Universal Gripper Based on the Jamming of Granular Material”, IEEE transactions on robotics