

MULTIPLE ANFIS OSERVERS BASED SENSOR FAULT DETECTION AND CONTROL IN A SATELLITE LAUNCHER

S.Nagarajan¹, S.Kayalvizhi², B.Karthikeyan³

¹Dept. of Electronics and Instrumentation Engg, Easwari Engineering College, Chennai, (India)

²Dept. of Computer Science and Engg, Easwari Engineering College, Chennai, (India)

³Dept. of Electronics and Instrumentation Engg, Velammal Engineering College, Chennai, (India)

ABSTRACT

Sensor failure detection and identification has been considered as an important issue, particularly when the measurements from sensors are used in the feedback loop of a control law. Kalman filters and Luenberger observers have been widely used to generate signal redundancy by means of state estimation. Dedicated observer scheme and generalized observer scheme are the older methods available for the evaluation of the residual to distinguish a particular fault from other. These methods are based on quantitative models of the system dynamics and these applications are limited to linear systems. To overcome the problems due to modeling error and non-linearity of the system, the proposed intelligent FDI system uses Multiple Adaptive Neuro-Fuzzy Inference System (MANFIS) which is functionally equivalent to Sugeno fuzzy model. ANFIS is the combination of an ANN and FIS in which observers are developed as FIS and ANN is used to determine the parameters of this fuzzy system. Since these observers are designed based on input-output relationships instead of mathematical model of a process, this FDI overcomes the problem of modeling errors and the difficulties encountered in developing accurate analytical observers using mathematical model. In this work, such fault detector is designed and simulated for a satellite launcher. The individual failures of three sensors in the satellite launcher are considered and the results are discussed. The results show that the system is able to detect any sensor failure situations perfectly.

Keywords: Adaptive Neuro-Fuzzy Inference System, Reduced Order Observer, Satellite Launcher, Sensor Fault Detection, State Estimation

I. INTRODUCTION

In the case of unstable vehicles like satellite launchers, the failure of one sensor can be disastrous if the control system is not provided with redundancy. Due to this characteristic, it is important for these vehicles to identify sensor failures as quickly as possible and reconfigure the control law from the failed one to an alternative one. The purpose of the Fault tolerant control system is to detect, identify and accommodate sensor failures. Model based fault detection techniques are based on observers [1], state estimating filters [2] or Parameter Estimators [3]. In the observer techniques, the state observers estimate the states of a system. If the output variables are the same as the state variables, all states can be considered as unmeasurable states. Using reduced

order observers, the unmeasurable states can be estimated using measurable states. Thus it is possible to estimate the states from one or more other output variables without its own sensor. This leads to the concept of fault detection and control using the measurements only from the perfect sensors for getting the estimated state of the faulty sensor. The estimation error that is the difference between the sensor output and the corresponding state given by the observer, gives information regarding the failed sensor. A dedicated observer scheme [4] was introduced in which each sensor of interest drives an observer to perform a complete state estimation. In case where the actual system is non-linear, it is a matter of degree of non-linearity that determines if this method will be successful in the detection of a failure.

With the development of neural networks and fuzzy systems, fault detection uses these techniques since they do not need any mathematical model and can accommodate non-linearities [5]. The reduced order observer can be modeled using fuzzy system. A straightforward approach [6] is to assume a certain shape for the membership functions. The effectivity of the fuzzy models representing nonlinear input-output relationships depends on the fuzzy partition of the input-output spaces. Therefore, the tuning of membership functions becomes an important issue in fuzzy modeling. Since this tuning task can be viewed as an optimization problem, neural networks can be used to solve this problem. The shape for the membership functions that depends on different parameters that can be learned by a neural network with a set of training data in the form of correct input-output relationships and a specification of the rules including a preliminary definition of the corresponding membership functions. In the earlier work of the author, the Adaptive neuro-fuzzy system which is a neural network, fix the optimal shape and parameters for the membership functions and effective rule base for the fuzzy system for observer modeling [7].

In another work of the author, the levels in the three tanks of interacting level process are measured as states and used to control the level in the third tank through state feedback. Six Observers using Multiple Adaptive neuro-fuzzy Inference System (MANFIS) are designed with sensor outputs as inputs to estimate all the states of the process and they can be feedback for control [8]. The results of this fault tolerant logic is proved successful for the stable system and is extended to unstable system like satellite Launcher in this work.

In this work, three states are measured in the longitudinal control of satellite launcher and used to control the vehicle through state feedback. Three Multiple adaptive neuro-fuzzy observers [MANFIS] are designed each with two states as inputs. These three designed observers measure all the states of the system and the measured states are feedback for control. The fault detection and Identification logic detects any fault that occurs and identifies the failed sensor. This fault detection and identification is followed by accommodation using reconfiguration of the control law that performs the fault tolerant control.

II. MATHEMATICAL MODEL

The mathematical model used to describe the longitudinal motion of the satellite launcher is given by equation (1) and can be found in [7] [9]. It describes the open loop dynamics of the longitudinal motion:

$$\dot{x} = Ax + Bu \quad (1)$$

with the state vector given by:

$$x^T = [\omega \quad q \quad \theta] \quad (2)$$

and
$$u = \beta_z \tag{3}$$

The matrices A and B in equation (1) are given in equations (4) and (5):

$$A = \begin{bmatrix} Z_w & U_0 + Z_q & -g \\ M_w & M_q & 0 \\ 0 & 1 & 0 \end{bmatrix} \tag{4}$$

$$B^T = [Z_{\beta_z} \quad M_{\beta_z} \quad 0] \tag{5}$$

The parameters $Z_w, Z_q, M_w, M_q, Z_{\beta_z}$ and M_{β_z} contained in matrix A and B, are the aerodynamic derivatives of the satellite launcher vehicle. The parameter U_0 is the flight speed of the vehicle and the parameter g is the gravity acceleration. The state variable ω is the vehicle velocity along the z-body axis, called normal velocity, the state variable q is the vehicle pitch-rate, that is, its angular velocity around the y-body axis and the state variable θ is the vehicle pitch -attitude with respect to y-body axis. The control β_z is the pitch control deflection. The data used for the vehicle are given in Table 1.

Table 1. Data used for the satellite launcher

Z_w (s^{-1})	U_0 ($m s^{-1}$)	Z_q ($m s^{-1}$)	g ($m s^{-2}$)	M_w ($m^{-1} s^{-1}$)	M_q (s^{-1})	Z_{β_z} ($m s^{-2}$)	M_{β_z} (s^{-2})
-0.0968	544.46	0.1631	9.7886	0.0096	0.0568	19.3761	7.2769

III. LONGITUDINAL CONTROL SYSTEM

The longitudinal control system is designed with the objective to track a reference pitch attitude, θ_{ref} and the regulation of the remaining states and the model is given in (6):

$$\begin{bmatrix} \dot{\omega} \\ \dot{q} \\ \dot{\theta} \\ \dot{e}_\theta \end{bmatrix} = \begin{bmatrix} Z_w & Z_q + U_0 & -g & 0 \\ M_w & M_q & 0 & 0 \\ 0 & 1 & 0 & 0 \\ 0 & 0 & -1 & 0 \end{bmatrix} \begin{bmatrix} \omega \\ q \\ \theta \\ e_\theta \end{bmatrix} + \beta_z + \begin{bmatrix} 0 \\ 0 \\ 0 \\ 1 \end{bmatrix} \theta_{ref} \tag{6}$$

where the state variable e_θ is the pitch-attitude error integral. This has been included to keep the steady state error near zero. The control system was designed by LQR method and the control law is given in (7):

$$\beta_z = -Kx - K_0 \theta_{ref} \tag{7}$$

with state vector x given in (8):

$$x^T = [\omega \quad q \quad \theta \quad e_\theta] \tag{8}$$

and the state feedback gain K is given in (9):

$$K = [K_1 \quad K_2 \quad K_3 \quad K_4] \tag{9}$$

and K_0 is the feed forward gain. The designed value of K is [0.0013 1.4551 3.3581 -3.2581] and the feed forward gain K_0 is -3.257. Fig. 1 shows the satellite launcher with this control law.

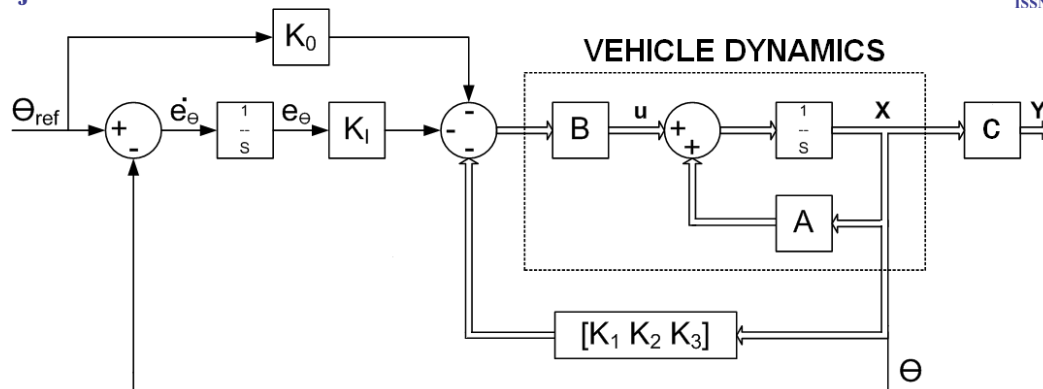

Fig. 1 Block diagram of longitudinal control of satellite launcher

IV. STATE ESTIMATORS

In this system, the measurements of all states are possible since the output variables are same as state variables. This makes no requirement for any state estimation. Under sensor fault condition, the sensor output gives incorrect output and for implementing fault detection, state estimations are carried out on the assumption that only two state variables are measurable and the third state under estimation corresponding to the fault sensor output is unmeasurable. Three such estimators are constructed for three sensors. Each Estimator is applied with two outputs in addition to the control input β_z . Thus the estimator E1 estimates ω with q, θ and β_z as inputs, E2 estimates q with ω, θ and β_z as inputs and E3 estimates θ with ω, q and β_z as inputs [10]. This is shown in the block diagram in Fig. 2.

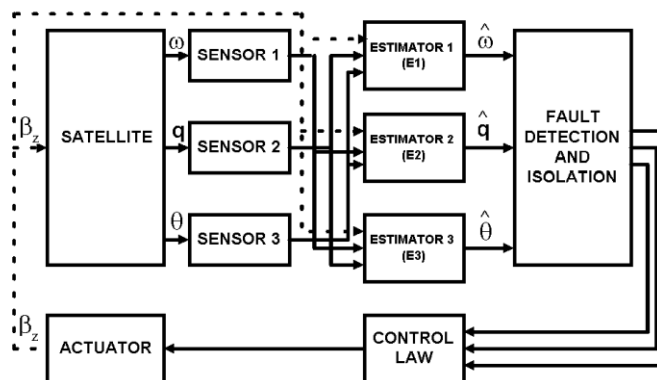

Fig.2 Block diagram of fault detection scheme with state estimators

V. ADAPTIVE NEURO-FUZZY INFERENCE SYSTEM

A Neuro-fuzzy system is a combination of an Artificial Neural Network (ANN) and a Fuzzy Inference System in such a way that neural network learning algorithms are used to determine the parameters of the Fuzzy Inference System. A fuzzy inference system (FIS) can utilize human expertise for storing its essential components in a rule base and a database and perform fuzzy reasoning to infer the overall output value. For building a fuzzy inference system, the fuzzy sets, fuzzy operations and the knowledge base should be specified. For building an Artificial Neural Network, it is necessary to specify the learning algorithm and the architecture. The learning mechanism of the ANN does not rely on human expertise. Due to the homogeneous structure of the

ANN, it is difficult to extract structured knowledge from the weights of the ANN. Hence encoding *a priori* knowledge into the ANN becomes a difficult task. Neuro-fuzzy system is a hybrid system that combines the learning capability of FIS and the formation of fuzzy if-then rules by ANN. ANN learning algorithms are used to determine the parameters of the FIS.

Adaptive Neuro-Fuzzy Inference System (ANFIS) [11] implements a Takagi Sugeno FIS and has a five layered architecture as shown in Fig. 3. The first hidden layer is for fuzzification of the input variables and T-norm operators are deployed in the second hidden layer to compute the rule antecedent part. The third hidden layer normalizes the rule strengths followed by the fourth hidden layer where the consequent parameters of the rule are determined. Output layer computes the overall input as the summation of all incoming signals. ANFIS uses back-propagation learning to determine premise parameters to learn the parameters related to membership functions and least mean squares estimation to determine the consequent parameters. The learning procedure is executed in two parts. In the first part, the input patterns are propagated and the optimal consequent parameters are estimated by an iterative least mean squares procedure, while the premise parameters are assumed to be fixed for the current cycle through the training set. In the second part the patterns are propagated again, and in this epoch, back-propagation is used to modify the premise parameters, while the consequent parameters remain fixed. This procedure is then iterated.

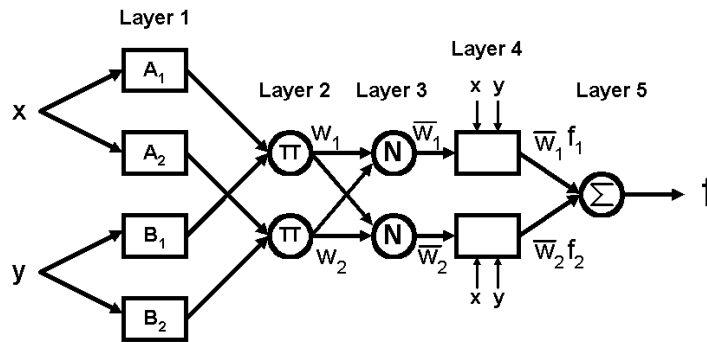

Fig. 3 Architecture of an Adaptive Neuro-Fuzzy Inference System (ANFIS)

VI. MULTIPLE ADAPTIVE NEURO-FUZZY OBSERVERS AS STATE ESTIMATORS

An adaptive network with above structure which is functionally equivalent to Takagi Sugeno fuzzy model is constructed as an observer to give the estimated state value as its output. The inputs are the control input and the other two sensor outputs. The result is the estimated value of sensor measurement whose output is not considered.

Multiple Neuro-Fuzzy Inference System (MANFIS) is a parallel structure with two ANFIS sharing same inputs to produce multiple outputs as shown in Fig. 4. An adaptive network with ANFIS structure is constructed as a generalized observer whereas MANFIS structure is constructed as a dedicated observer. Three dedicated observers are designed with such Multiple Adaptive Neuro-Fuzzy observers for normal velocity estimation, Vehicle Pitch rate estimation and pitch attitude estimation respectively.

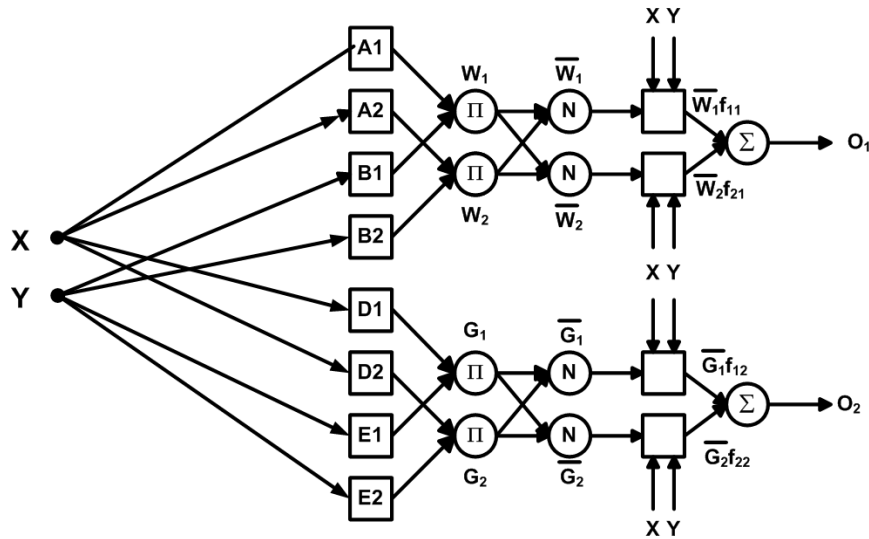

Fig. 4 Architecture of a Multiple Adaptive Neuro-Fuzzy Inference System (MANFIS)

The neural networks are trained with the known input-output relationships of satellite launcher in possible ranges. The optimal shape and parameters for the membership functions of fuzzy inference systems with effective rule base are fixed by neural networks for each observer as listed in Table 2.

Table 2. Shape and parameters of membership functions

Observer designed for	Input membership functions		No.of rules	Output membership functions	
	Total No.	Type		Total No.	Type
Velocity estimation	17	Gauss	17	17	Linear
Pitch rate estimation	11	Gauss	11	11	Linear
Pitch estimation	17	Gauss	17	17	Linear

VII. FAULT DETECTION AND IDENTIFICATION

The decision functions are to be built to detect a failed sensor and then to reconfigure the control law from the basic control law to an alternative one. The decision functions η_1 , η_2 and η_3 are formed in the following way from the estimated values of states given by MANFIS observer and the sensor outputs. Estimated states from E1, E2 and E3 are respectively given in (10):

$$\hat{x}_1 = \hat{\omega}, \quad \hat{x}_2 = \hat{q} \quad \text{and} \quad \hat{x}_3 = \hat{\theta} \quad (10)$$

The estimation error that is the difference between the sensor output and its observer is calculated as f_1, f_2 and f_3 for all states respectively as given in (11):

$$f_1 = \left| \omega - \hat{x}_1 \right|, \quad f_2 = \left| q - \hat{x}_2 \right| \quad \text{and} \quad f_3 = \left| \theta - \hat{x}_3 \right| \quad (11)$$

The decision functions η_1, η_2 and η_3 are given by equation (12):

$$\eta_1 = f_2 f_3, \quad \eta_2 = f_1 f_3 \quad \text{and} \quad \eta_3 = f_1 f_2 \quad (12)$$

The values of the decision functions will be zero if no sensor fails. If any sensor fails, the decision function formed from the product of estimation errors will show great deviation. For example, if the sensor of the pitch attitude θ fails, the functions f_1 and f_2 will grow quickly and so η_1 will grow much faster. This deviation is used to identify that the pitch sensor has failed and to make the fault alarm to do the reconfiguration of the control law. If the normal value of this decision function is fixed at zero, even a slight deviation, which is not necessarily because of sensor failure, can also make fault alarm. This false alarm is avoided by fixing threshold values for the decision functions instead of zero.

VIII. FAULT TOLERANT CONTROL

If any sensor failure is identified by the fault detection and identification logic, the estimated state which is also the output in this case, will come into action and give the values of the state of the system for feedback. Hence perfect and smooth control is possible even under sensor failure conditions. The system under no failure condition will work with the basic control law given by equation (13):

$$\beta_z = -K_1\omega - K_2q - K_3\theta - K_1e_\theta - K_0\theta_{ref} \quad (13)$$

If any failure is detected in the pitch attitude θ sensor, the control law will be modified and the alternative control law is given in (14):

$$\beta_z = -K_1\omega - K_2q - K_3\hat{x}_3 - K_1e_\theta - K_0\theta_{ref} \quad (14)$$

where e_θ is calculated from its derivative given in equation (15):

$$\dot{e}_\theta = \dot{\theta}_{ref} - \hat{x}_3 \quad (15)$$

For pitch-rate q sensor failure and the normal velocity ω sensor failure, the alternative control laws are given in equations (16) and (17) respectively:

$$\beta_z = -K_1\omega - K_2\hat{x}_2 - K_3\theta - K_1e_\theta - K_0\theta_{ref} \quad (16)$$

$$\beta_z = -K_1\hat{x}_1 - K_2q - K_3\theta - K_1e_\theta - K_0\theta_{ref} \quad (17)$$

IX. SIMULATION RESULTS

The simulation is conducted under no failure condition. The state feed back control is applied for maintaining the pitch attitude at 0.1 rad. No sensor failure is introduced and the various trends on states, state estimates, estimation error functions, the decision functions and Fault alarms are shown in Fig. 5. The decision functions are within their threshold values and no fault alarms are generated.

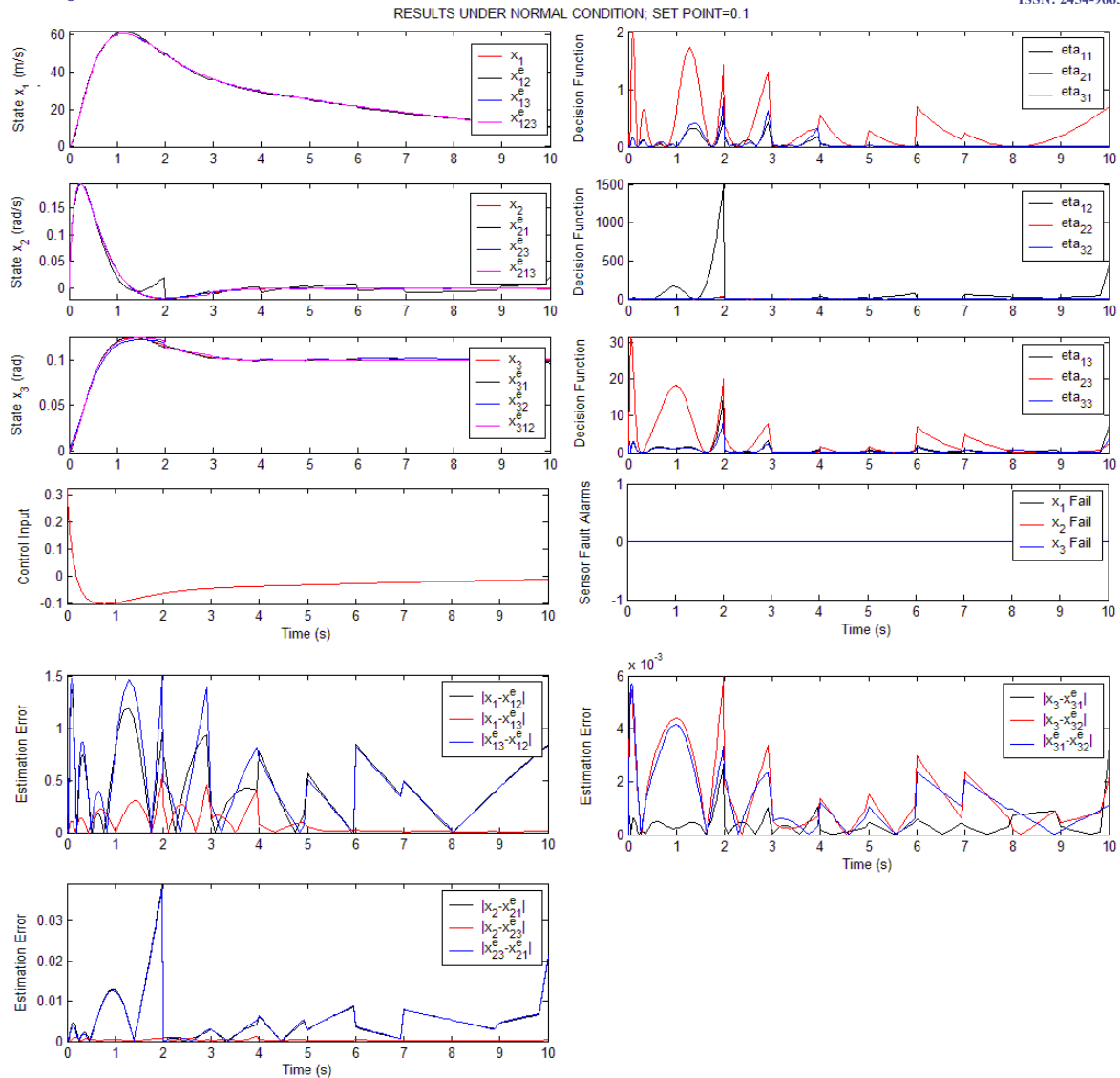

Fig. 5 Trends on states, state estimates, estimation error functions, the decision functions and Fault alarms under no Sensor Failure Condition

For the same system, a failure is introduced in normal speed sensor ω at 1 s. The trends on states, state estimates, estimation error functions, the decision functions and fault alarms are shown in Fig. 6. The estimates developed from ω sensor measurement deviate more and the error functions relating these estimates grow faster at 1 s. The decision functions η_{11} , η_{12} and η_{13} go beyond their respective threshold values and a fault alarm is generated for ω sensor failure at 1 s. All other decision functions are found within their respective threshold values and hence no false alarms are reported. The pitch is maintained at the desired value even under this sensor failure condition since the control law is reconfigured as given in Equation (17).

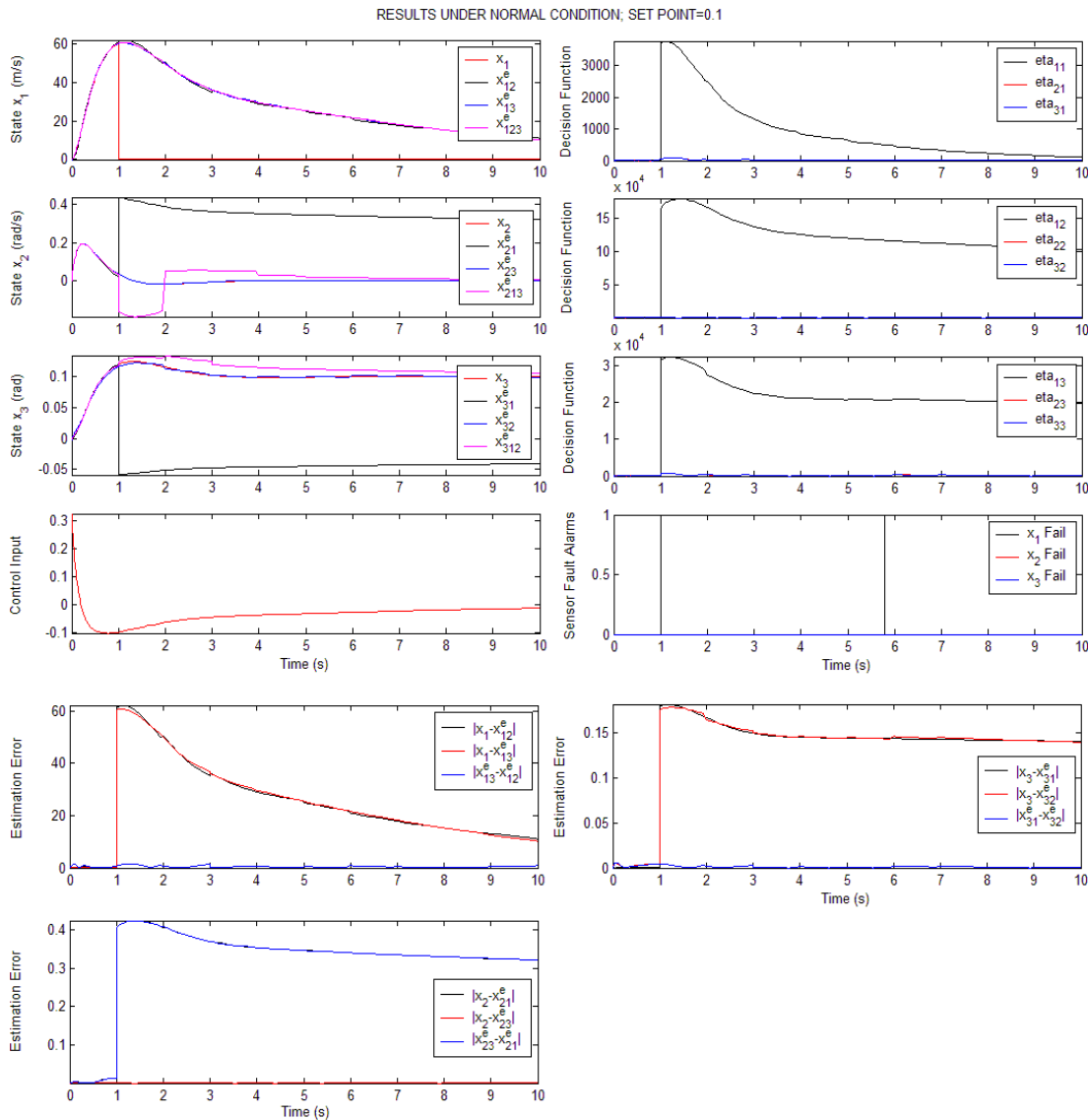

Fig. 6 Trends on states, state estimates, estimation error functions, the decision functions and Fault alarms under normal velocity Sensor Failure Condition.

Similar experiments are conducted for pitch rate sensor failure condition and pitch-attitude sensor failure conditions and it is observed that fault alarms are reported at the time of introduction of the errors.

X. CONCLUSION

Three dedicated observers are designed using Multiple adaptive neuro-fuzzy inference system by fixing the optimal shape and parameters of the membership functions and effective rule base by neural networks to estimate the normal velocity, pitch rate and pitch attitude of a satellite launcher. From the study performed it has been noticed that the system has detected failures within 0.03 seconds in any sensor if it occurs. The sensor that failed is correctly identified through the reporting of fault alarms. The control law is modified accordingly and the pitch attitude is maintained at the desired value even under the failure conditions. No missed alarm and false alarm are reported. Since the effect of change in system parameters and noises on estimation are not

considered in this work, further work is suggested to improve the performance of the estimators so that no false alarms are reported in such environments as well.

REFERENCES

- [1]. Frank, P.M., Fault Diagnosis in Dynamic Systems using Analytical and Knowledge Based Redundancy- A Survey and Some new results, *Automatica*, 26(3), 1990, 450-772.
- [2]. Willsky, Alan.S., A Survey of Design Methods for Failure Detection in Dynamic Systems, *Automatica*, 12, 1976, 601-611.
- [3]. Isermann, R., Process Fault Detection based on Modeling and Estimation methods - A survey, *Automatica*, 4, 1984, 387-404.
- [4]. Clark, R.N., Fosth, D.C. and Walton, V.M., Detecting Instrument Malfunctions in control systems, *IEEE transactions on Aerospace and electronic Systems*, AES-11(4), 1975, 465-473.
- [5]. Napolitano, M.R., Neppach, C. et. al., Neural Network based scheme for Sensor Failure Detection, Identification, and Accommodation, *J. Guidance, Control and Dynamics*, 18(6), 1995, 1280-1286.
- [6]. Xiao-Jun Ma and Zeng-Qi sun, Analysis and Design of Fuzzy Controller and Fuzzy Observer, *IEEE Transactions on Fuzzy systems*, 6(1), 1998, 41 –50.
- [7]. Nagarajan.S., Shanmugam.J. and Rangaswamy.T.R., Sensor Fault Detection in a Satellite Launcher using Adaptive Neuro-Fuzzy Observer, *Journal of Aerospace Sciences and Technologies*, 59, 2007., 41-59.
- [8]. Nagarajan.S., Shanmugam.J. and Rangaswamy.T.R., MANFIS Observer based Sensor Fault Detection and Identification in Interacting Level Process with NN Based Threshold Generator, *International Journal of Soft Computing*, 3(5), 2008, 344-354.
- [9]. Oliva, A.P., Sensor Fault detection and Analytical Redundancy Satellite Launcher Flight Control System, *SBA Control and Automation*, 9(3), 1998, 156-164.
- [10]. Patton, R., Frank, P., Clark, R., *Fault Diagnosis in Dynamic Systems: Theory and Applications* (Prentice Hall Int, series in systems and Control Engineering, Englewood Cliffs, NJ, 1989).
- [11]. Jang, J.S.R., Sun. C.T, Mizutani, E., *Neuro-Fuzzy and Soft Computing - A Computational approach to Learning and Machine Intelligence* (Prentice Hall, Upper saddle River, NJ, 1997).