

ORGANIZE AND SEEK PHYSICAL ITEMS BY REAL TIME EMBEDDED APPLICATIONS USING RASPBERYPi

L. Nishanthini

*Assistant Professor, Department of ECE, Kommuri Pratap Reddy
Institute of Engineering and Technology*

ABSTRACT

An embedded is a word touches our ears daily in every aspect of life, we cannot imagine world without electronics. As the human needs are increasing life is becoming more simplified and sophisticated thus demand for consumer electronics is more. Organizing of physical items, search and seeking them at requirement by a human depends on his expertise, experience and mainly on his mind set. This can be recognized as highly unreliable and depends on the person.

This paper deals about one such system: search and find an organized way of handling physical items. It is implemented with a microcontroller and raspberry pi which takes the commands from the system and activates to open corresponding item. Each physical items has an address location and accessible only through computing system with an RF linkage and actuator unit which physically drives in physical items to pop out.

KEY WORDS: *Device drivers, SOC, RF, Raspberry Pi.*

I. INTRODUCTION

Organizing of physical items at requirement by a human depends on his expertise. This can be recognized as highly unreliable and depends on the person. When there are many number of items in unorganized way like CD's in CD shop, medicines in medical stores, book in library, automobile parts etc. It is a difficult task to seek required object manually and time consuming. Earlier we have manual search, they should be manually operated. Some require memory and these increase manual effort. Some are more advanced than the manual organizers. These organizers are operated using personal computers to reduce manual effort but they depend on human memory. A solution which can organize and seek them at requirements is possible only with a simple computing, large memory and a wireless interface.

Primarily there are two sections; first section deals with computing and data storage. Second section deals about hardware realization. For computing the data we use raspberry Pi which has a Broadcom BCM2835 system on a chip (SoC), which includes an ARM1176JZF-S 700MHz processor (The firmware includes a number of "Turbo" modes so that the user can attempt overclocking, up to 1 GHz, without affecting the warranty), VideoCore IV GPU, and was originally shipped with 256 megabytes of RAM, later upgraded to 512 MB. It does not include a built-in hard disk or solid-state drive, but uses an SD card for booting and long-term storage capacity. Coding is done on Linux platform with debian flavor using python language. Instructions are given through a computing system over RF module with baud rate set to 9600.

The second section is activator and organizer. This receives commands from the computing system through an RF link. An RF receiver is interfaced to the activator board in which microcontroller receives data and processes the data, according to the given commands from the system respective rack will pop out through a mechanical action.

II. DESIGN AND IMPLEMENTATION

Primarily there are two sections in this project. First section is about data storage in pen-drive or system. Data consists of names of the items to be organized physically. Each of the item names is assigned with a particular number which is the identity in the physical organizer. Data in the pen-drive or system is entered manually at this stage itself at each of the entries the respective tray from the organizer gets ejected. The item can be placed in the tray and pushed back to its position. Once this is done then name and the number of the tray is assigned and saved. Similarly it can be operated to fill upto 240 items per microcontroller board. Each microcontroller board has its own identity and is unique. This uniqueness is stored in its dedicated EEPROM. Beyond this another mc board can be connected on the same serial port. The second section is activator and organizer. This receives commands and the data from the system through an RF link. An RF transmitter is fixed on the serial port of the system; an RF receiver is interfaced to the activator board to receive data and commands from the system. Once the data is received the controller depending upon the commands activates a particular tray from a particular rack, received data is displayed on LCD. The activator consists of power switching device to activate a particular electro mechanical solenoid. The solenoid in turn pulls the hook from the spring loaded tray catch. Once this is activated the tray gets ejected from the loaded spring and indicates a flashing LED in front of the particular tray.

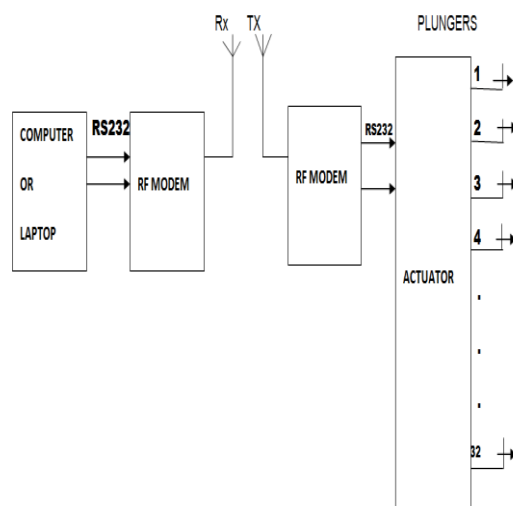

Fig 1 block diagram of the project

III. TRANSMITTER SECTION

In transmitter section we use raspberry pi as data storage and processing device. When the power of the transmitter section is ON then the RF module is powered. The transmission and the reception pins of the RF

module is connected to the one end of the RS 232 cable the other end of the RS232 cable is connected to the computing system. After connecting the cable to the computer system the battery is connected to the RF module. Then according to data stored in the data base we can give the search command.

Computing system should be speed, high data storage capability and smaller in size. All this features remind us of system on chip (SoC). Like raspberry pi which is even cost effective, compact in size and runs on Linux platform in debian flavor which is virus free. Under computing back end programming can be any high level language; in our project we used python language to write the code on raspberry pi, for storing the data as well as to seek the data from the database. This can be assessable by common man without any complications.

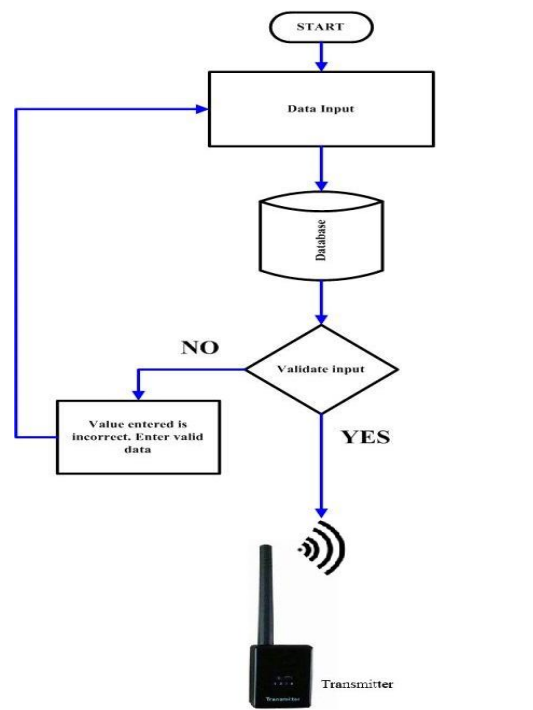

Fig 2: flow chart for transmitting section.

Once the data is sent through transmitter, it is received by RF linkage in the receiver section.

IV. RECEIVER SECTION

The receiver section receives commands and the data from the system through an RF link. An RF transmitter is fixed on the serial port of the system; an RF receiver is interfaced to the activator board to receive data and commands from the system. Once the data is received the controller depending upon the commands activates a particular tray from a particular rack, received data is displayed on LCD. The activator consists of power switching device to activate a particular electro mechanical solenoid. The solenoid in turn pulls the hook from the spring loaded tray catch. Once this is activated the tray gets ejected from the loaded spring and indicates a flashing LED in front of the particular tray. When a particular name is typed on the keyboard and searched at the transmitter side. The data in the form of bits is received the receiver section RF module. The RF module in the receiver section understands it and sent it to the RS 232circuit from its output port.

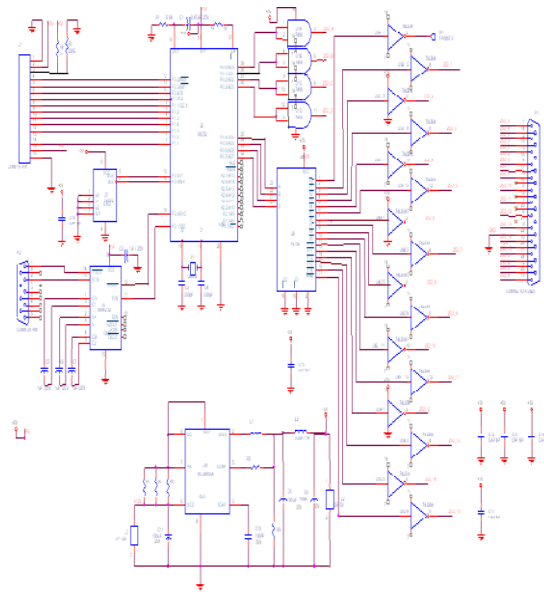

Fig 3: circuit diagram of receiver section.

At RS 232circuit: The RS 232 circuit converts the digital information received by it from RF module to actuator board. The RS 232circuit send this info from its output port to the actuator board.

At Actuator: The microcontroller board receives the instruction. Then it compares the instruction with the code which is dumped into it. As per the code the processor instructs the organizer (driver card) to function. This instruction is sent from the specified output pins on the processor to the particular driver circuit.

According to the information given by RS 232 the particular child card and the respective slide information is displayed on the LCD screen.

At organizer: The driver card then receives the command from the controller. It then controls the solenoids attached to particular slide exactly as the user wanted to by receiving the commands from the controller. And the respective slide pops out.

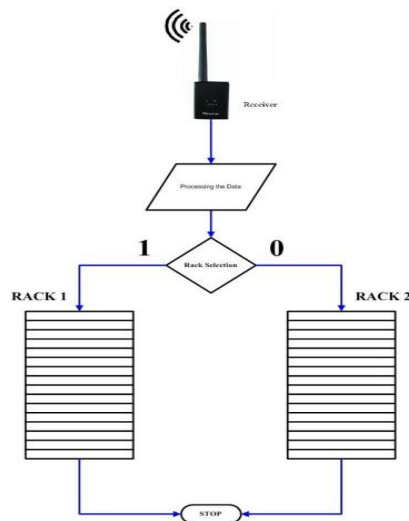

Fig 4: flow chart for hardware realization

	Model A	Model B
Target price:	US\$ 25	US\$ 35

V. HARDWARE

Initial sales are of the Model B, with plans to release the Model A in early 2013. Model A has one USB port and no Ethernet controller, and will cost less than the Model B with two USB ports and a 10/100 Ethernet controller. Though the Model A doesn't have an 8P8C (RJ45) Ethernet port, it can connect to a network by using a user-supplied USB Ethernet or Wi-Fi adapter. There is in reality no difference between a model A with an external Ethernet adapter and a model B with one built in, because the Ethernet port of the model B is actually a built-in USB Ethernet adapter. As is typical of modern computers, generic USB keyboards and mice are compatible with the Raspberry Pi.

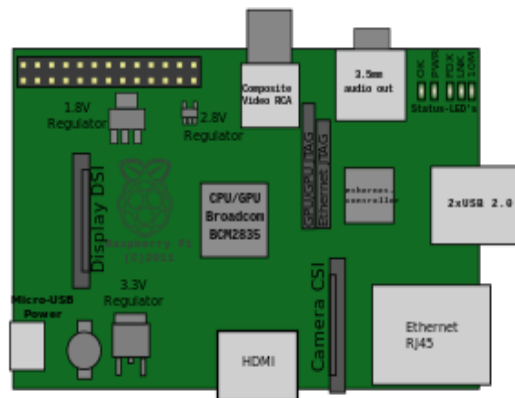

Fig 5: Location on the PCB of connectors and major ICs

The Raspberry Pi does not come with a real-time clock, so an OS must use a network timeserver, or ask the user for time information at boot time to get access to time and date for file time and date stamping. However, a real-time clock (such as the DS1307) with battery backup can be added via the I²C interface. On 20 April 2012 the Raspberry Pi Foundation released the schematics for the Model-A and Model-B.

Hardware accelerated video (H.264) encoding became available on 24 August 2012 when it became known that the existing license also covered encoding. Previously it was thought that encoding would be added with the release of the announced camera module. However, for the time being, there is no stable software support for hardware H.264 encoding. At the same time the Raspberry Pi Foundation released two additional codecs that can be bought separately, MPEG-2 and Microsoft's VC-1. Also it was announced that the Pi will support CEC, enabling it to be controlled with the television's remote control.

On 5 September 2012, a revision 2.0 board was announced, with a number of minor corrections and improvements. On 15 October 2012, the Raspberry Pi foundation announced that all new Raspberry Pi model B's would be fitted with 512 MB instead of 256 MB RAM.

5.1 Specifications

SoC:	Broadcom BCM2835 (CPU, GPU, DSP, SDRAM, and single USB port)	
CPU:	700 MHz ARM1176JZF-S core (ARM11 family, ARMv6 instruction set)	
GPU:	Broadcom Video Core IV @ 250 MHz OpenGL ES 2.0 (24 GFLOPS) MPEG-2 and VC-1 (with license), 1080p30 h.264/MPEG-4 AVC high-profile decoder and encoder	
Memory (SDRAM):	256 MB (shared with GPU)	512 MB (shared with GPU) as of 15 October 2012
USB 2.0 ports:	1 (direct from BCM2835 chip)	2 (via the built in integrated 3-port USB hub)
Video input:	A CSI input connector allows for the connection of a RPF designed camera module	
Video outputs:	Composite RCA (PAL and NTSC), HDMI (rev 1.3 & 1.4), raw LCD Panels via DSI 14 HDMI resolutions from 640×350 to 1920×1200 plus various PAL and NTSC standards.	
Audio outputs:	3.5 mm jack, HDMI, and, as of revision 2 boards, I ² S audio (also potentially for audio input)	
Onboard storage:	SD / MMC / SDIO card slot (3,3V card power support only)	
Onboard network:	None	10/100 Ethernet (8P8C) USB adapter on the third port of the USB hub
Low-level peripherals:	8 × GPIO, UART, I ² C bus, SPI bus with two chip selects, I ² S audio +3.3 V, +5 V, ground	
Power ratings:	300 mA (1.5 W)	700 mA (3.5 W)
Power source:	5 volt via MicroUSB or GPIO header	
Size:	85.60 mm × 53.98 mm (3.370 in × 2.125 in)	
Weight:	45 g (1.6 oz)	
Operati	Arch Linux ARM, Debian GNU/Linux, Fedora,	

ng	FreeBSD, NetBSD, Plan 9, Raspbian OS, RISC
systems	OS, Slackware Linux
:	

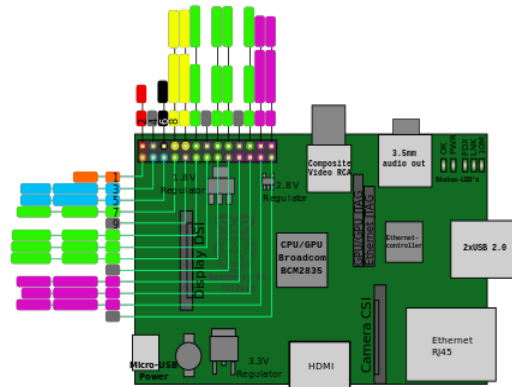

Fig 6: Pinout-diagram for Rev. 1 Board

5.2 Accessories

The Foundation reported on its blog in May 2012 about a prototype camera module they have tested. The prototype used a 14-megapixel module, while the released version will be 5 megapixels.

On 14 May 2013 the foundation and the distributors RS Components & Premier Farnell/Element 14 launched the Raspberry Pi camera board with a firmware update to support it. The camera board is shipped with a flexible flat cable that plugs into the CSI connector located between the Ethernet and HDMI ports. In Raspbian the installing or upgrading to the latest version of the OS and then running Raspi-config and selecting the camera option can enable support. The cost of the camera module is 20 EUR in Europe (2013-06-09). It even supports 1080p, 720p, 640x480p video. The footprint dimensions are 25 x 20 x 9 mm.

A number of Raspberry Pi specific peripheral devices and cases are available from third-party suppliers. These include the Raspberry Pi Foundation sanctioned Gertboard, which is designed for educational purposes, and expands the Raspberry Pi's GPIO pins to allow interface with and control of LEDs, switches, analog signals, sensors and other devices. It also includes an optional Arduino compatible controller to interface with the Pi.

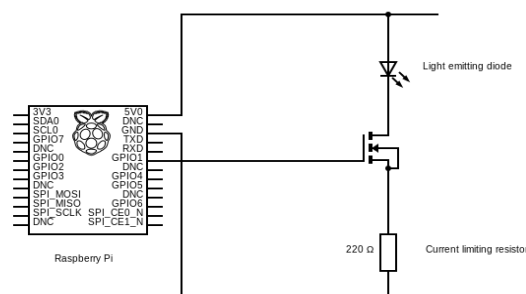

Fig 7: Using GPIO pins to control an LED

5.3 Computing section

When the power of the transmitter section is ON then the RF module is powered. The transmission and the reception pins of the RF module is connected to the one end of the RS 232 cable the other end of the RS232

cable is connected to the computing system. After connecting the cable to the computer system the battery is connected to the RF module. Then according to data stored in the data base we can give the search command.

Computing system should be speed, high data storage capability and smaller in size. All this features remind us of system on chip (SoC). Like raspberry pi which is even cost effective, compact in size and runs on Linux platform in debian flavor which is virus free.

Debian is an operating system composed of free software mostly carrying the GNU General Public License. The operating system is developed by an internet collaboration of volunteers aligned with The Debian Project. Its focus of different kernels makes it appeal to different titles, such as DebianGNU/Linux and DebianGNU/kFreeBSD. Debian GNU/Linux is one of the most popular Linux distributions for personal and Internet server machines. Debian is seen as a solid Linux, and as a consequence has been used as a base for other Linux distributions; Distrowatch lists 144 active Debian derivatives. Debian has been forked many times, but is not affiliated with its derivatives. The vital role the Debian project plays in free software is demonstrated by its advancement of development and security patches relating to its strong participation in CVE compatibility efforts. Coding is done in python program language;

Python is a widely used general-purpose, high-level programming language. Its design philosophy emphasizes code readability, and its syntax allows programmers to express concepts in fewer lines of code than would be possible in languages such as C. The language provides constructs intended to enable clear programs on both a small and large scale. Python supports multiple programming paradigms, including object-oriented, imperative and functional programming or procedural styles. It features a dynamic type system and automatic memory management and has a large and comprehensive standard library.

Like other dynamic languages, Python is often used as a scripting language, but is also used in a wide range of non-scripting contexts. Using third-party tools, Python code can be packaged into standalone executable programs (such as Py2exe, or Pyinstaller[]). Python interpreters are available for many operating systems.

VI. CONCLUSION

WIRELESS ELECTRONIC ORGANIZER is been designed and implemented with embedded system domain using RF Communication. Experimental work has been carried out carefully. The proposed method is verified to be highly beneficial for wireless operation. Using this paper we can reduce human effort as far as possible. As time is very precious for an individual, the proposed technology reduces time consumption in various applications. It has a wide applications in various field. This can be upgraded to achieve more tasks.

ADVANTAGES: Reduces the human activity, physical strain. Gives spontaneous output. Ease of operation, Low maintenance cost, Fit and forget system, No wastage of time, Durability, Accuracy. It can be upgradable by increasing the number of racks and microcontrollers.

APPLICATIONS: In a vast collection of CDs, sometimes the shopkeeper may get confused and consume a lot of time in searching for a CD. This design helps in searching a CD within seconds.

It increases the efficiency of the person working at an office, save his time in searching for a particular file or an object. Library is a store house of books. These books include various subjects of various authors, many volumes. It may be difficult for a person to search a book from many within no time.

A medical store consists of many kinds of medicines where, searching for them becomes difficult. In this application medicines if stored in a proper manner in a particular rack can be accessed easily without confusion. FUTURE SCOPE: By using a device called "RASPBERRY PIE" - A CPU on single chip, we can reduce power consumption, decrease the hardware components size and also make it application specific instead of using a PC. It can be implemented for large store houses which consists of many objects which consumes more time in searching. It can also be applied in many areas where manual search is required.

REFERENCES

- [1] J Hill, R Szewczyk, A Woo, S Hollar, D Culler, K Pister, in ASPLOS-IX: Proceedings of the ninth international conference on Architectural support for programming languages and operating systems. System architecture directions for networked sensors (ACM Press, New York, 2000) pp. 93–104
- [2] S. Fischmeister and P. Lam. On time-aware instrumentation of programs. In RealTime and Embedded Technology and Applications Symposium. 15th IEEE, pages 305–314, 2009
- [3] Rudolf F. Graf, "reed relay" Dictionary of Electronics; Radio Shack, 1974-75. Fort Worth, Texas.
- [4] J.R. Agre, L.P. Clare, G.J. Pottie, and N.P. Romanov, "Development platform for self-organizing wireless sensor networks" SPIE Conf. on Unattended Ground Sensor Tech. and App., Orlando FL April 1999, vol. 3713 pp. 257-267
- [5] Pottie, G. J., "Wireless Sensor Networks," 1998 Information Theory Workshop, pp 139-40, 22-26 June 1998.
- [6] Hansen, C. J. and Pottie, G. J., "A Distributed Access Algorithm for Cellular Radio
- [7] Systems with Channel Partitioning," IEEE Transactions on Vehicular Technology, vol. 48, no. 1, pp 76-82, January 1999.
- [8] Chen, J., et al., "A Comparison of MAC Protocols for Wireless Local Networks Based on Battery Power Consumption," IEEE INFOCOM 1998, vol. 1, pp 150-7.
- [9] Parsec: A Parallel Simulation Environment for Complex Systems," R. Bagrodia, R.
- [10] Meyer, M. Takai, Y. Chen, X. Zeng, J. Martin, B. Park, H. Song; IEEE Computer, Vol.31(10), October 1998, pp. 77-85.

ABOUT AUTHOR

Lakkireddy Nishanthini¹ has received her Bachelor of Technology degree in Electronics & Communication Engineering from KITE College, JNTUH. College, in the year 2011. Master of Technology degree from VBIT College, JNTUH, in the year 2013. Served as technical administrator in Unisoft technologies for 2 years. Then worked as Assistant Professor in Samskruti College of Engineering for 1 year. Currently Working as Assistant Professor in Kommuri Pratap Reddy Institute of Engineering and Technology.