

COMBINED BASE ISOLATION FOR ASYMMETRIC BUILDINGS

Prof. Kadlag V.A¹, Prof. Kenkar K.S², Prof. Deosarkar M.U³

¹ Assistant Professor, Department of Civil Engineering,

Dr. D Y Patil School of Engineering & Technology Lohgaon, Pune, (India)

² Assistant Professor, Department of Civil Engineering,

Parvatibai Genba Moze College of Engineering, Wagholi, Pune (India)

³ Assistant Professor, Department of Civil Engineering,

Dr. D Y Patil School of Engineering & Technology Lohgaon, Pune (India)

ABSTRACT

Earthquake causes significant loss of life and damage of property every year. Seismic base isolation is one of the most widely implemented and accepted seismic passive control protection systems. Seismic base isolation is a technique that mitigates the effects of an earthquake by essentially isolating the structure and its contents from potentially dangerous ground motion, especially in the frequency range where the building is most affected. Base isolation is very promising technology to protect different structures like building, water tanks, bridges, airport terminals and nuclear power plants etc. from seismic excitation.

In this research, 6-storey reinforced concrete structures are designed as isolated and fixed-base. We'll examine the response of buildings isolated using combined isolation system (CIS) consisting of High Damping Rubber Bearing (HDRB), Lead Rubber Bearing (LRB) and Friction Pendulum System (FPS) at the base column are used. Uniform Building Code (UBC-97) is used for design of base isolation systems. Non-linear time history analysis is considered in the modelling. The behaviours of designed models under dynamic loads are analysed using ETABS2015 v.15.0.0 computer software. Bhuj (India) Earthquake is chosen as the ground motions. At the end of analysis, time period, storey shear, storey displacements are compared for isolated and fixed-base structures.

Keywords: Seismic Isolation, Bearing Isolators, Irregular Building, Non-Linear Time History, HDRB, LRB, FPS.

I INTRODUCTION

Natural hazards bring many damages to manmade interventions such as habitat and infrastructural facilities causing loss to life and property. Earthquakes are one of those hazards with the sudden violent movement of earth's surface with the release of energy. These energy travels in the form of seismic waves which affects the structures. The development of recent technologies for the control of seismic hazards catches the attention of structural engineers to make the structures seismically resistant. The seismic base isolation technique is a passive protective system. It limits the effects of the earthquake attack through a flexible base which decouples

the structure from the ground motion, and the structural response accelerations are usually less than that of the ground acceleration. The goal is to simultaneously reduce interstorey drifts and floor accelerations to limit or avoid damage, not only to the structure but also to its contents, in a cost-effective manner. The three basic characteristics of an isolation system are: (1) horizontal flexibility to increase structural period and reduce spectral demands (except for very soft soil sites), (2) energy dissipation (also known as damping) to reduce isolator displacements, and (3) sufficient stiffness at small displacements to provide adequate rigidity for service-level environmental loadings. The horizontal flexibility common to all practical isolation systems serves to uncouple the building from the effects of high frequency earthquake shaking typical of rock or firm soil sites, thus serving to deflect the earthquake energy and significantly reduce the magnitude of the resulting inertia forces in the building. Energy dissipation in an isolation system, in the form of either hysteretic or viscous damping, serves to reduce the displacement response of an isolation system generally resulting in more compact isolators.

Structural response and isolator displacement are two key parameters to decide the characteristics of an isolation system. In near-field area isolator displacement plays pivotal role in governing the design of an isolation system, as large isolator displacements leads failure of isolation system. To check isolator displacement, stiffness of isolation system is increased but such increase adversely affects the structural response, especially floor accelerations. Present study aimed to explore the role of increase of isolation stiffness on structural response of a building. Bi-linear isolation system is selected for the study. The bilinear model, used to express the relation between the shear force and the lateral displacement, can be defined by three parameters: pre-yield stiffness, post-yield stiffness, and characteristic strength. The characteristic strength, Q , is usually utilized to estimate the stability of hysteretic behaviour when the bearing experiences many loading cycles. These three parameters properly reflect the mechanical properties of bearings and provide satisfactory estimations of a bearing's nonlinear behaviour. . The specific objectives of the study are: (i) to investigate the effects of increase of pre-yield stiffness on structural response, (ii) to analyse the effect of isolation period on structural response and, (iii) to investigate the effects of characteristic strength ratio of isolator on structural response.

Many comparative studies have revealed that the responses of the isolated structure are significantly smaller than the fixed base structure [1], [2], [3], [4], [5], and [6]. Most of these studies compared the seismic demands (e.g. storey displacement, storey drift, storey acceleration and storey shear) for the two types of building structures, but only a limited number of studies investigated the responses of the isolated structure using high damping rubber (HDR) isolation with detailed procedures of the design of HDR. Skinner et al. [7] indicated that a base isolator with hysteretic force-displacement characteristics can provide the desired properties of isolator flexibility, high damping and force limitation under horizontal earthquake loads, together with high stiffness under smaller horizontal loads to limit wind-induced motions.

Kelly [8] gave a brief introduction to the response mechanisms of base isolated buildings through two degrees of freedom linear system. The effectiveness of the isolation system to mitigate the seismic response is through its ability to shift the fundamental frequency of the system out of the range of frequencies where the earthquake is strongest. Also, Skinner et al. [7] demonstrated that the most important feature of seismic isolation is that its

increased flexibility increases the natural period of the structure. Because the period is increased beyond that of the earthquake, resonance is avoided and the seismic acceleration response is reduced.

II RELATED WORK

2.1 Regular and Irregular structures

According to the Indian Standard, structures are designated as structurally regular or irregular. A regular structure has no significant discontinuities in plan, vertical configuration, or lateral force resisting systems. An irregular structure, on the other hand, has significant discontinuities such as those in IS1893 (Part 1): 2002 Table 4 (plan irregularities) and Table 5 (vertical irregularities). To perform well in an earthquake, a building should possess four main attributes, namely simple and regular configuration, and adequate lateral strength, stiffness and ductility. Buildings having simple regular geometry and uniformly distributed mass and stiffness in plan as well as in elevation, suffer much less damage than buildings with irregular configurations.

The failure of structure starts at points of weakness. This weakness arises due to discontinuity in mass, stiffness and geometry of structure. The structures having this discontinuity are termed as Irregular structures. Vertical irregularities are one of the major reasons of failures of structures. Height-wise changes in stiffness and mass render the dynamic characteristics of these buildings different from the regular building. The irregularity in the building structures may be due to irregular distributions in their mass, strength and stiffness along the height of building.

There are basically two types of irregularities-

1. Plan Irregularities
2. Vertical Irregularities

There are again various types plan irregularities such as,

- a) Torsional Irregularity
- b) Extreme Torsional Irregularity
- c) Re-entrant Corners
- d) Diaphragm Discontinuity
- e) Out-of-plane Offsets
- f) Non-parallel Systems

There are again various type vertical irregularities such as,

- a) Stiffness Irregularity
 - i. Soft Storey
 - ii. Extreme Soft Storey
- b) Mass Irregularity
- c) Vertical Geometric Irregularity
- d) In-Plane Discontinuity in Vertical Elements Resisting Lateral Force
- e) Discontinuity in Capacity — Weak Storey

Re-entrant Corners plan irregularity

Plan configurations of a structure and its lateral force resisting system contain re-entrant corners, where both projections of the structure beyond the re-entrant corner are greater than 15% of its plan dimension in the given direction. Fig. 1.1 shows the re-entrant Corners plan irregularity.

Vertical Geometric Irregularity

Vertical geometric irregularity shall be considered to exist where the horizontal dimension of the lateral force resisting system in any storey is more than 150% of that in its adjacent storey. Fig. 1.2 shows the Vertical Geometric Irregularity.

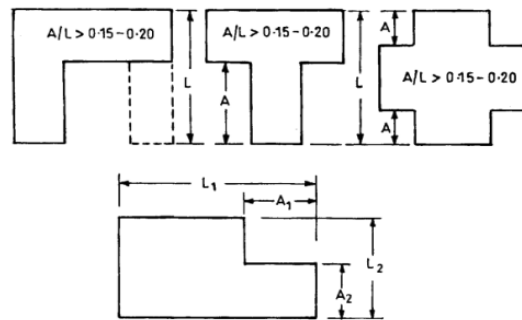

Figure 2.1 Re-entrant Corners plan irregularity

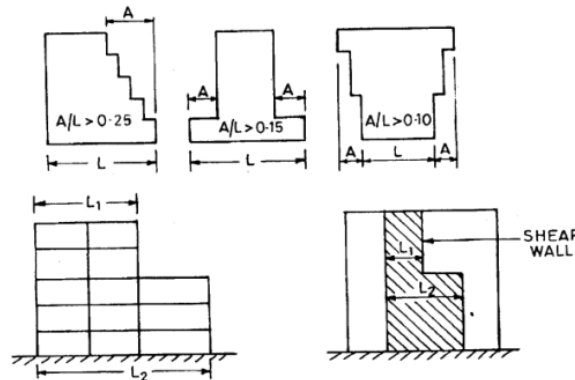

Figure 2.2 Vertical Geometric Irregularity

III STRUCTURAL PROPERTIES AND MODELING

3.1 Building data and geometry

Two building of G+5 stories plan irregular and vertical irregular are modeled as of fixed base building and analysed with soft computing tool ETABS 2015 V 15.0.0. Non- linear dynamic analysis (i.e. Time-history analysis) of building is carried out by considering Bhuj (India) (7.7) time history data and response of the buildings are calculated. Each building has 4 bays by 4 bays square plan dimensions 20m*20m and each bay is 5m in x-direction and y-direction. These structures are designed according to Indian Standards. The height of each story of the building is 3.2m and a column height of 1.5m has been extended below the plinth beams. Parapet height is 1.2m. A solid slab of thickness 150mm has been considered for all storeys. Slab is modelled as a rigid diaphragm. As per IS: 875(Part-2)- 1987, Live load intensity of 3 kN/mm² has been assumed on each storey and the roof has been assumed a uniform live load intensity in 1.5 kN/mm². The seismic zone is IV. Grade of concrete is M20 and for steel Fe415. The values of various factors have been assumed as per IS:

1893(Part-1) -2002. Size of Columns for all storeys is 300*500mm and size of Beams for all storeys is 300*400mm. External wall thickness is 230mm and internal wall thickness is 115mm for both buildings. Floor finish on floor is 1.5kN/m^2 and floor finish on roof is 2kN/m^2 . Figure 2.1 shows the plan and 3D elevation model of plan irregular building and figure 3 shows the 2D and 3D elevation model of vertical irregular building.

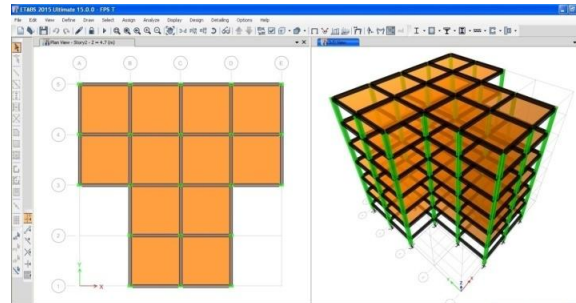

Figure 3.1. T shape plan irregular building

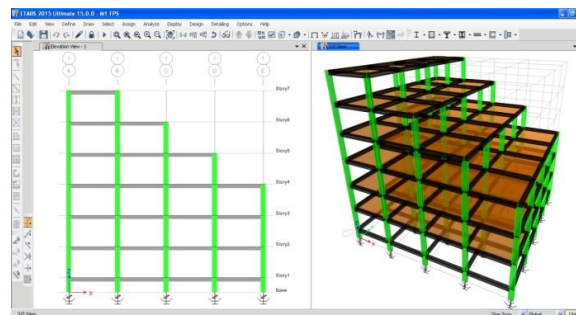

Figure 3.2. Vertical geometric irregular building

3.2 Models considered for analysis

Asymmetric (G+5) storey RC buildings was isolated at its base using three types of isolation systems discussed. First we used the HDRB as the only device (let's call it BI-HDRB), then we used the LRB (BI-LRB) and finally the FPS (BI-FPS). The isolation devices designed for it using the UBC-97 (UBC, 1997) requirement. As a first remark it is evident from the geometric characteristic (size) of isolators that the BI-LRBs will cost more than the other buildings, and this must be taken into account. A nonlinear time history analysis using ETABS2015 (v15.0.0) (Computers and Structures, 2015) assuming the Bhuj (India) record was carried out for all structure.

Plan of T shape irregular and vertical irregular (G+5) storey RC buildings with separately mounted & different combinations of isolators showing in figure 2.3 and figure 2.4 respectively are as follows-

FIXED: Plan of building with fixed base

HDRB: Plan of building with High Damping Rubber Bearing

LRB: Plan of building with Lead Rubber Bearing

FPS: Plan of building with Friction Pendulum System Bearing

Model 1A: Plan of building with Combinations of HDRB & LRB *i.e.* HDRB on external column base and LRB on internal column base

Model 1B: Plan of building with Combinations of HDRB & LRB *i.e.* LRB on external column base and HDRB on internal column base

Model 2A: Plan of building with Combinations of HDRB & FPS *i.e.* HDRB on external column base and FPS on internal column base

Model 2B: Plan of building with Combinations of HDRB & FPS *i.e.* FPS on external column base and HDRB on internal column base

Model 3A: Plan of building with Combinations of FPS & LRB *i.e.* FPS on external column base and LRB on internal column base

Model 3B: Plan of building with Combinations of FPS & LRB *i.e.* LRB on external column base and FPS on internal column base

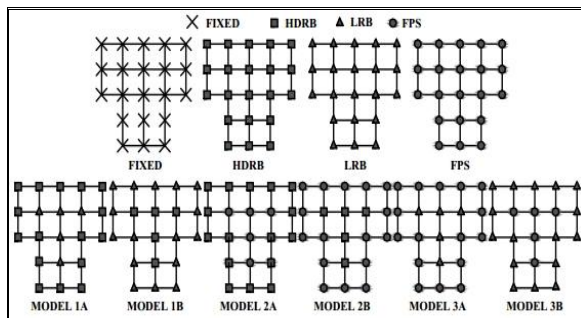

Figure 3.3 Plan irregular building plan

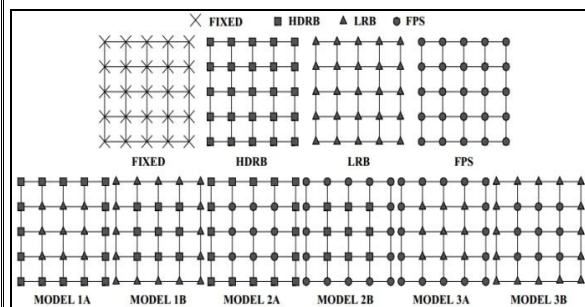

Figure 3.4 Vertical irregular building plan

IV RESULTS AND DISCUSSION

4.1 Results of plan irregular building

- Time Period

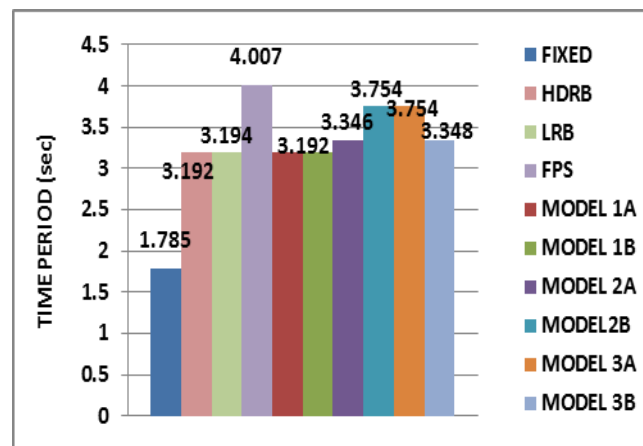

Figure 4.1 Time Period

From figure 4.1, it is observed that the time period in all 9 models is increased more than 45% compared to fixed base. But FPS increases the time period compared to other combinations. In combinations, Model 2B & Model 3A more increases as compared to other combinations.

- Storey Shear

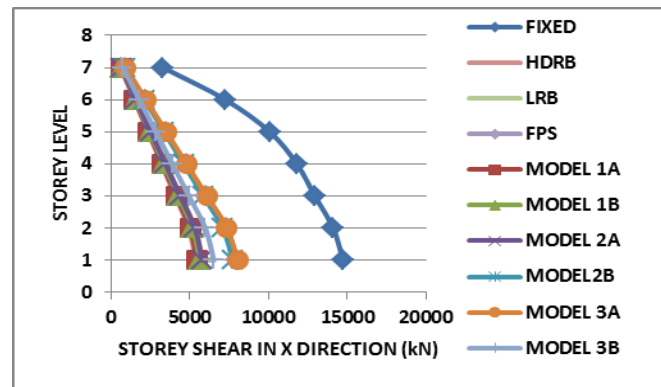

Figure 4.2 Storey shear in x-direction

From figure 4.2, it is observed that storey shear in X-direction is reduced in all 9 models as compared to fixed base, but storey shear more reduced in HDRB & in combinations model 1A as compared to others.

• **Storey Displacement**

From Figure 3.3, it is observed that the storey displacement in x-direction is increased for the all 9 models when compared with fixed base. But in case of FPS is more increased in x-direction with other models. In Combinations, model 2B & model 3A is more increased in X-direction.

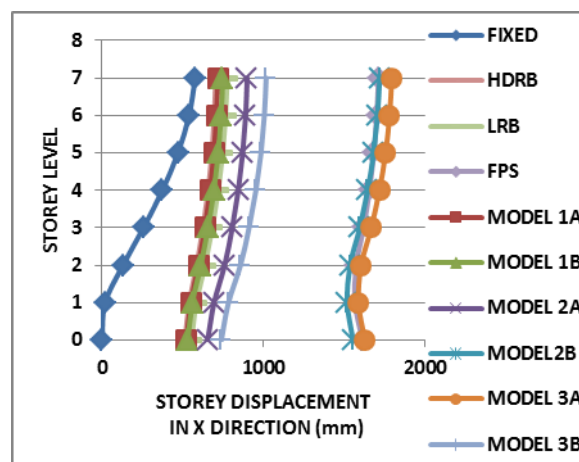

Figure 4.3 Storey Displacement in x-direction

4.2 Results of vertical irregular building

• **Time Period**

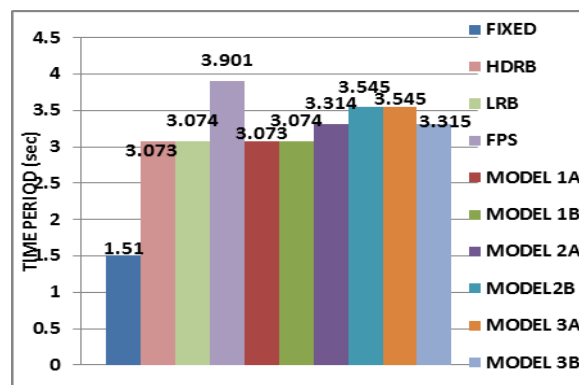

Figure 4.4 Time Period

From figure 4.4, it is observed that the time period in all 9 models is increased more than 45% compared to fixed base. But FPS increases the time period compared to other combinations. In combinations, Model 2B & Model 3A more increases as compared to other combinations.

- Storey Shear**

From figure 4.5, it is observed that storey shear in X-direction is reduced in all 9 models as compared to fixed base.

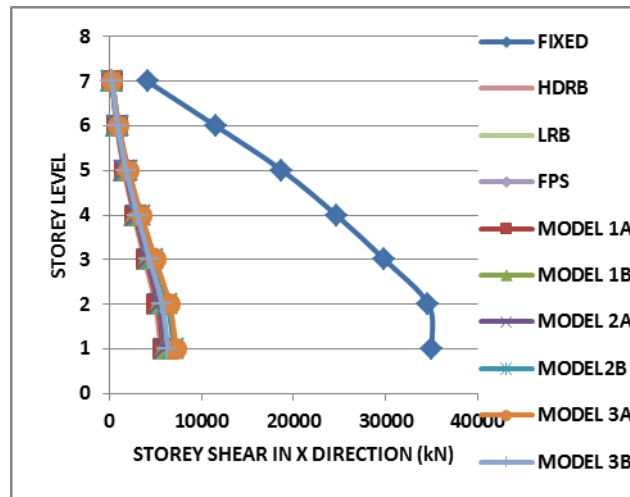

Figure 4.5 Storey shear in x-direction

- Storey Displacement**

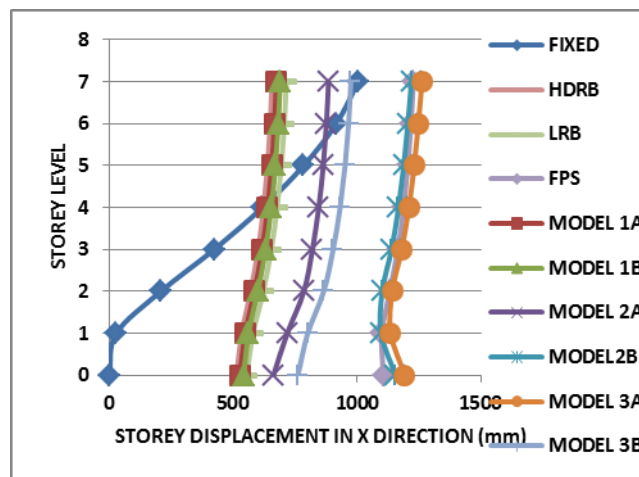

Figure 4.6 Storey Displacement in x-direction

From Figure 4.6, it is observed that the storey displacement in x-direction is increased for the all 9 models when compared with fixed base. But in case of model 3A is more increased in x-direction with other models.

V CONCLUSION

Three different isolation systems were investigated when mounted separately and when mounted in combination. Analytical research on dynamic behaviours of the combined isolation system and seismic response analysis of plan and vertical irregular structure with the isolation system are carried out. Time Period, Storey shear and storey displacements responses of structure with the combined base isolation and with fixed base are compared.

- i. It is concluded that time period of the plan irregular building in case of FPS, HDRB & LRB is increased by about 2.222 seconds, 1.407 seconds & 1.409 seconds respectively as compared to fixed base. In combined isolation system, time period in Model 2B & 3A is increased by about 1.969 seconds & 1.969 seconds respectively.
- ii. It is concluded that time period of the vertical irregular building in case of FPS, HDRB & LRB is increased by about 2.391 seconds, 1.563 seconds & 1.564 seconds respectively as compared to fixed base. In combined isolation system, time period in Model 2B & 3A is increased by about 2.035 seconds & 2.035 seconds respectively.
- iii. It is concluded that the reduction of storey shear in plan irregular building is more in HDRB than LRB & FPS. In combined isolation system, storey shear in Model 1A & 2B is more reduced as compare to other combined isolation models.
- iv. It is observed that fixed base building have zero displacement at base of building whereas, all base isolated building models shows increase in amount of lateral displacements at base. Also it has been observed that as floor height increases, lateral displacements increases drastically in fixed base building as compare to base isolated building. Due to this reduction in lateral displacement during earthquake damages of structural as well as non structural is minimized.
- v. It is observed that combined isolation system helps to increase time period & storey displacement and to decrease storey shear, storey drift and storey acceleration.
- vi. When isolators are arranged that inner and outer column at base in plan of building such a combination of HDRB&LRB, HDRB&FPS and FPS&LRB, it is observed that in combination of HDRB&FPS and FPS&LRB, when FPS is placed on outer column at base *i.e.* Model 2B & Model 3A are more effective as compared to other combination models.

REFERENCES

- [1] M. Leblouba, "Combined Systems for Seismic Protection of Buildings", *International symposium on strong vrancea earthquakes and risk mitigation, Bucharest, Romania, Oct. (4-6) 2007*, pp. 1-11, 2007.
- [2] T.R. Wankhade and A.R. Wankhade, "Effect Of Combined Isolation System On Low-Rised RC Structure", *International Journal of Informative & Futuristic Research (IJIFR) Volume - 3, Issue -2, October 2015*, pp. 538-550.2015.
- [3] F. Braga, M. Laterza and R. Gigliotti, "Seismic isolation using slide and rubber bearings: large amplitude vibration tests on Rapolla Residence Building", *7th International Symposium on Seismic Isolation, Passive Energy Dissipation and Active Control of Vibrations of Structures, Assisi, Italy*, pp.1-31. 2001.
- [4] Manoj U. Deosarkar and S.D. Gowardhan, "Non Linear Dynamic Response Of Combined Isolation System On Symmetric And Asymmetric Buildings", *International Journal of Informative & Futuristic Research (IJIFR) Volume - 3, Issue -2, November 2015*, pp. 1021-1035, 2015.
- [5] N. Torunbalci and G. Ozpalanlar, "Earthquake Response Analysis of Mid-Story Buildings Isolated with Various Seismic Isolation Techniques" *The 14 World conference on earthquake engineering, October 12-17, 2008*, pp. 1-8, 2008.

- [6] N. Torunbalci and G. Ozpalkanlar, “Evaluation of Seismic Response for Low-Rise Base Isolated Building”, *The 14 World conference on earthquake engineering, October 12-17, 2008*, pp. 9-16, 2008.
- [7] R.I. Skinner, W.H. Robinson and G.H. Mc Verry, “An Introduction to Seismic Isolation”, *New York: John Wiley & Sons, Inc.*; 1993.
- [8] N. Naeim and J.M. Kelly, “Design of Seismic Isolated Structures from Theory of Practice”, *The reference book*, 1999.
- [9] N. Takalkar and D.K. Paul, “Seismic Response of Friction Pendulum Isolated Medium Rise Multi-storey Buildings”, *International Journal of Engineering Science and Technology (IJEST)*, Vol. 4 No. 06, June 2012, pp. 1-12, 2012.
- [10] W. Shi, H. Sun and Q. Wang, “A Study On Combined Isolation System”, *13th World Conference on Earthquake Engineering Vancouver, B.C., Canada, August 1-6, 2004*, paper no. 2232, 2004.
- [11] R.S. Jangid, & A. Sharma, “Behaviour of Base-Isolated Structures with High Initial Isolator Stiffness”, *World academy of science engineering and technology*, 26-2009, pp. 1-6, 2009.
- [12] CSI Analysis Reference Manual for ETABS®, SAP2000®, and SAFE™.
- [13] UBC97, “Uniform Building Code”, Chap. 16, Div. I 1601 1605.2.1 Volume 2.