

MICROCONTROLLER EDUCATIONAL KIT

Ms. Rupali H.Nangare¹, Mr. Nitin Mahadkar²

Swapnali Mohite³, Priyadarshani Kalbhor⁴

¹Asst. Prof., E&TC Dept., ADCET Ashta

^{2,3,4}Student, E & TC Dept., ADCET Ashta

ABSTRACT

This is the research paper which confines the very well, how efficiently we can use a single Microcontroller to build all in one educational kit. The main part of this paper is to build a system by having all the necessary devices using one microcontroller IC. We can interface all devices and basic components. Here, we are not required to provide different power supplies to different devices unlike other kits available in market, we are providing a common power supply to all components i.e. on board power supply is present on kit itself. The different interfacings we have provided here are viz. LCD of 16x2 lines, Stepper Motor, ADC, DAC, Serial Communication(GSM/GPS/UART), Relays, LEDs, Keypad of 4x4, Temperature Sensor. We have also arranged power supplies of 12V and 5V on board itself.

Keywords: *Microcontroller, Components, On board power supply.*

I. INTRODUCTION

To learn the interfacings of devices or dealing with industrial work we are required to take individual kits for each and every device. It is not convenient method for learning any interfacings system. While in any industrial work, using such different kits for a single task, it will be so bulky as well as costlier as we need to buy different kits. We are providing a multitasking kit in order to learn interfacings which are all in one kit as such facilities are provided. This educational kit is based on microcontroller. It will be very much helpful to all the students to learn microcontroller based concept in only one kit. It includes LCD interfacing, ADC, DAC, Stepper motor, Matrix keypad, Relay, GSM/GPS, UART. We were using different interfacing kits for LCD, LED, STEPPER, MOTOR, BUZZER, RELAY, KEYPAD, ADC, DAC, GSM/GPS, UART etc. using microcontroller. By this kit we will have all the interfacing options on a single kit. This will reduce the hardware and will be easy to handle. Also the cost and maintenances for this kit will be comparatively less. This is simply a plug-and-play kit as we are not required to provide any external power supply as supply is also present on kit so that it will need to just plug the AC pins of kit. Basically this kit is well suited for educational purpose for learning concepts interfacings and can be efficiently used for industrial tasks. We have selected the microcontroller to work on it to have the interfacings is because microcontroller is next generation of Microprocessor by having RAM & ROM inbuilt which are the essentials for new interfacings and microcontroller is the basics of PIC & Embedded processors with enough ports available of external connections. Microcontroller is less complicated than other next versions of it.

II.PROPOSED SYSTEM

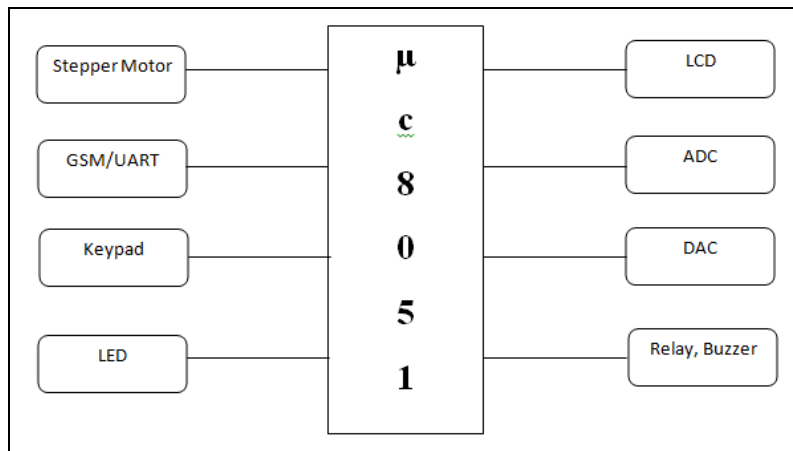

Fig. 1 Block diagram of proposed system

III.PERFORMANCE ANALYSIS:

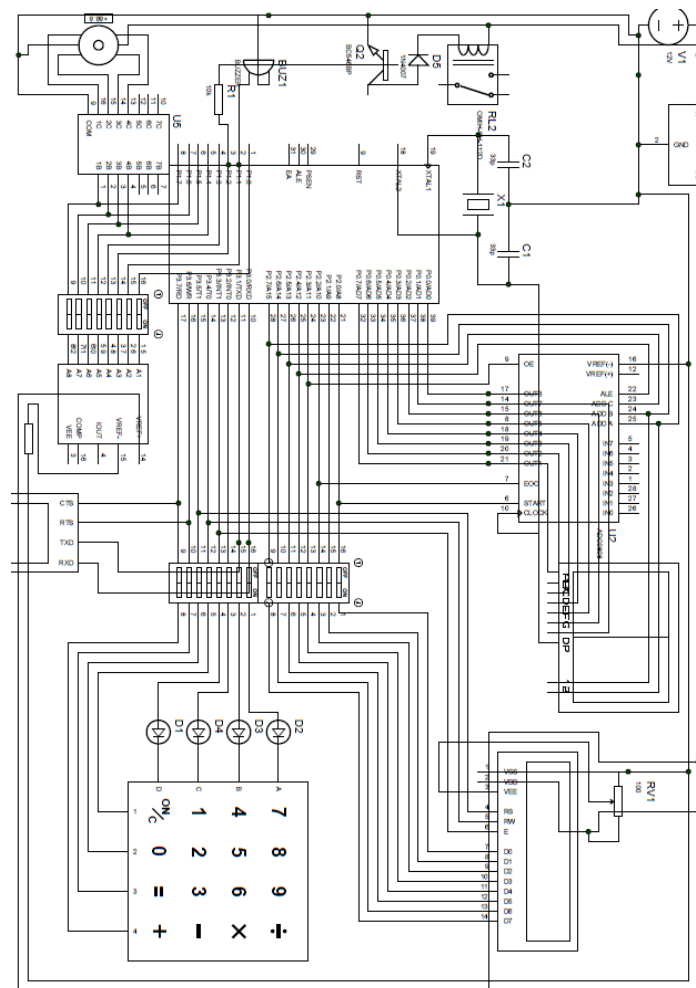

Fig.2 Circuit Diagram

This is basically an educational kit which is an alternate but very efficient replace to the old kits which were in use till date. We have utilized all the ports of microcontroller to provide interfacing of LCD by connecting it to

the Port 0 which will display outputs of programs in different styles in different font sizes, LCD is of 16x2 lines, port 1 will have all the connections of 4x4 matrix keypad which will need while giving input values in microcontroller programming, the stepper motor which mostly used in running devices different applications like used in disk rotations as well as mainly in any tasks where rotations are required, again the same port 2 connects 2 Relays of 12V each which works as switch and supplies to further load/circuit. The port 3 confines to connect ADC which is of 1 channel ADC with 8 bit resolution. It is used for converting any analogous signals to their digital formations, the same port connects to DAC. It provides high resolution while converting the digital inputs to its equivalent analogous outputs as it of 8 bit resolution. For serial communication here an RS-232 female pin been is placed on board as a UART. This female port is been connected to Rx and Tx pins of microcontroller.

Apart from all these interfacings this kit of circuitry includes 12V and 5V DC power supply which could be used for other purposes. This kit is also arranged in a manner that all the pins of ports of Microcontroller can be again utilized while already in a working condition i.e. while it is busy in doing other interfacings it could help to have other connections too. This kit is so efficiently made that it could have many different future expansions.

The layout for system is made in “Orcad 9.2” This kit would have a PCB layout as shown below:

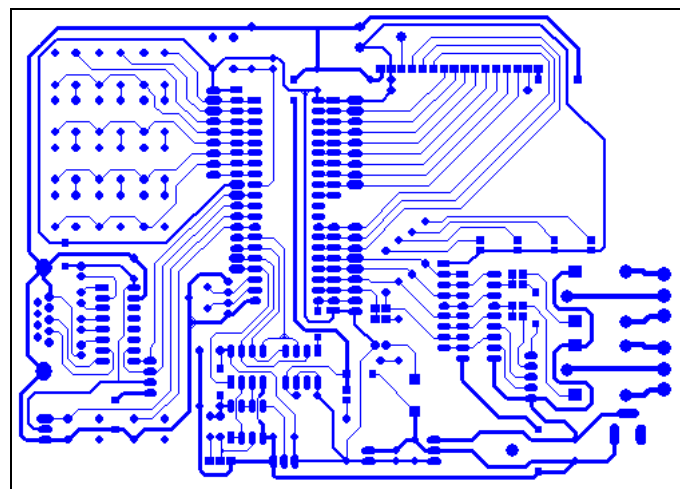
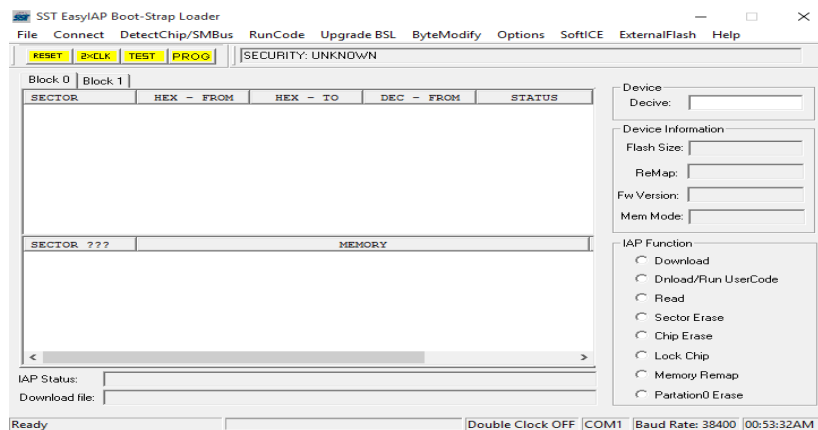

Fig.3 PCB layout

After completion of all the hardware part then it comes to the software building part of system. This deals with burning of whole program of interfacings of different devices/components in Microcontroller IC. There are different burning of processes of programs in IC-8051 but here the “SSTEasyIAP Boot” is been used as because the IC-8051 is manufactured by the same “SST Developers”.



The final model after completing all the hardware and software parts of kit it looks as Shownbelow.

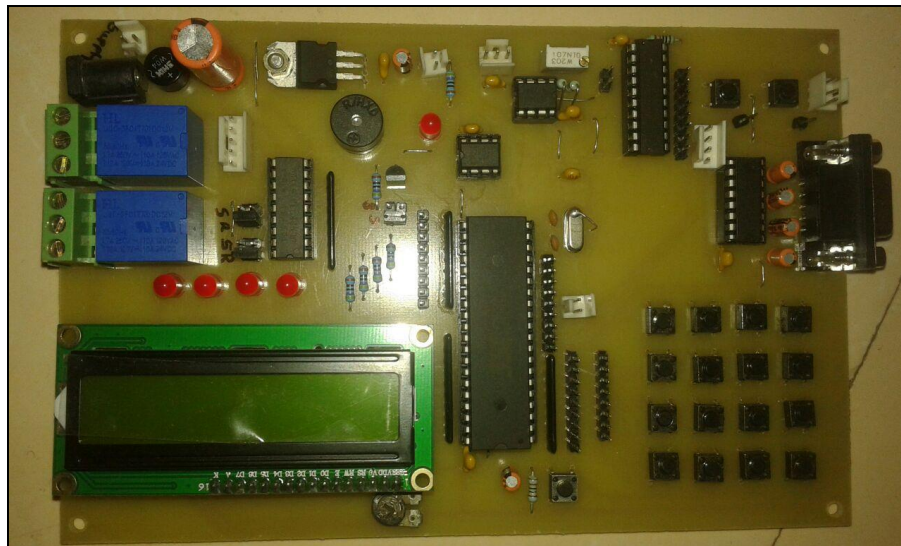

Fig.4 Final Hardware

IV.CONCLUSION

Through this system we have reached to the aim of integrating modern technologies on the same kit. In this project we can interface devices on same kit. Not required to provide additional power supplies to different devices. We can apply all theoretical knowledge about microcontroller and related devices.

The future advancements of this humble idea of ours can be the realization of a single board solution that will impregnate within itself interfacing unit, along with a microcontroller (89C51). This will not only reduce the size of the board but will also make it more robust and commercially available. It will be helpful for easy learning.

REFERENCES

- [1]. L.H. Hwang; J. H. Yoo; J.R. Kim; E.S. Jang; C.S. Lee Applications of Ferroelectrics,2002. ISAF 2002. Proceedings of the 13th IEEE International Symposium on ,2002
- [2]. ShouqianYu,Lili Yi ,WeihaiChen,Zhaojin Wen,," Implementation of a Multi-channel UART Controller Based on FIFO Technique and FPGA" 1-4244-0737-0/07/\$20.00 c 2007 IEEE

[3]. Akira Sugawara, Takashi Kenjo, “*Stepping Motors and Their icroprocessor Controls*”, Oxford University Press, 1995.

[4]. Definition of Microcontroller (<http://electrapk.com/what-is-a-microcontroller/>) (retrieved 5.3.2013)

Additional Reading

1. Atmel Corporation, (1997). 89S51/52 Flash Microcontroller Data Book.
2. <http://www.atmel.com/about/contact/default.aspx>. (retrieved 23.3.2013).
3. Innovative Electronics; (2002). 89C51 Development Tools DT- 51 version 3: User’s Guide, Surabaya.