

DESIGN OF G+5 MULTI-STOREY BUILDING

Manish Bisht, Aasim Arafat, Md. Aamin Akhtar

UG, Student, Civil Engineering Department, IIMT College of Engineering, Greater Noida

ABSTRACT

Structural design is the primary aspect of civil engineering. The very basis of construction of any building, residential house or dams, bridges, culverts, canals etc. is designing. The foremost basic in structural engineering is the design of simple basic components and members of a building viz., Slabs, Beams, Columns and Footings. In order to design them, it is important to first obtain the plan of the particular building that is, positioning of the particular rooms (Drawing room, bed room, kitchen toilet etc.) such that they serve their respective purpose and also suiting to the requirement and comfort of the inhabitants. Thereby depending on the suitability; plan layout of beams and the position of columns are fixed. Thereafter, the loads are calculated namely the dead loads, which depend on the unit weight of the materials used (concrete, brick), live loads, which according to the code IS:875-1987 is around 2kN/m², and the earthquake load according to IS 1893(PART 1):2002. Once the loads are obtained, the component takes the load first i.e the slabs can be designed. Designing of slabs depends upon whether it is a one-way or a two-way slab, the end conditions and the loading. From the slabs, the loads are transferred to the beam. The loads coming from the slabs onto the beam may be trapezoidal or triangular. Depending on this, the beam may be designed. Thereafter, the loads (mainly shear) from the beams are taken by the columns. For designing columns, it is necessary to know the moments they are subjected to. For this purpose, frame analysis is done by Moment Distribution Method. After this, the designing of columns is taken up depending on end conditions, moments, eccentricity and if it is a short or slender column. Finally, the footings are designed based on the loading from the column and also the soil bearing capacity value for that particular area. Most importantly, the sections must be checked for all the four components with regard to strength and serviceability.

I. INTRODUCTION

Engineering is a professional art of applying science to the efficient conversion of natural resources for the benefit of man. Engineering therefore requires above all creative imagination to innovative useful application for natural phenomenon. The basic needs of human existences are food, clothing's & shelter. From times immemorial man has been making efforts in improving their standard of living. The point of his efforts has been to provide an economic and efficient shelter. The possession of shelter besides being a basic, used, gives a feeling of security, responsibility and shown the social status of man.

Every human being has an inherent liking for a peaceful environment needed for his pleasant living, this object is achieved by having a place of living situated at the safe and convenient location, such a place for comfortable and pleasant living requires considered and kept in view.

- A Peaceful environment.
- Safety from all natural source & climate conditions.

- General facilities for community of his residential area.

There are many classical methods to solve design problem, and with time new software's

also coming into play. Here in this project work based on software named "STAAD. Pro" has been used.

Few standard problems also have been solved to show how "STAAD. Pro" can be used in different cases. These typical problems have been solved using basic concept of loading, analysis, condition as per IS code. These basic techniques may be found useful for further analysis of problems. STAAD Pro features a state-of-the-art user interface, visualization tools, powerful analysis and design engines with advanced finite element and dynamic analysis capabilities. From model generation, analysis and design to visualization and result verification, STAAD Pro is the professional's choice for steel, concrete, timber, aluminum and cold-formed steel design of low and high-rise buildings, culverts, petrochemical plants, tunnels, bridges, piles and much more. To perform an accurate analysis a structural engineer must determine such information as structural loads, geometry, support conditions, and materials properties. The results of such an analysis typically include support reactions, stresses and displacements. This information is then compared to criteria that indicate the conditions of failure. Advanced structural analysis may examine dynamic response, stability and non-linear behavior. Few standard problems also have been solved to show how "STAAD. Pro" can be used in different cases. These typical problems have been solved using basic concept of loading, analysis, condition as per IS code. These basic techniques may be found useful for further analysis of problems.

OBJECTIVE

- ❖ Test for safe bearing capacity of soil.
- ❖ Generating structural framing plan
- ❖ Creating model in STAAD PRO
- ❖ Application of loads on the member
- ❖ Analysis of the structure
- ❖ Design the structure .
- ❖ To make the structure more safer and economic .

METHODOLOGY

- MODELLING:
(C+G+5) Residential and Commercial building.

- LOADS:
1.5(Live Load +Dead Load).

- ANALYSIS:
Analysis of RCC framed structure.

Shear Force and Bending Moment calculations.

- DESIGN:
Design of Slab, Beam, Column, Footing and Staircase.

GEOMETRIC PARAMETERS:

Beam = 230 * 300mm.

Column = 230 * 300mm.

Slab = 150mm.

II. ANALYSIS DESIGN OF STRUCTURAL ELEMENTS

Design of slab Slabs are most widely used structural elements forming floor and roof of building. Slab support mainly transverse load and transfer them to supports by bending actions more or one directions. On the basis of spanning direction: It is two type one way slabs and two way slab.

❖ **One way slab:** When the slab is supported on two opposite side parallel edges, it spans only in the directions perpendicular to the supporting edges. It bends in one directions and main steel is provided in the directions of the span. Such a slab is known as one- way slab.

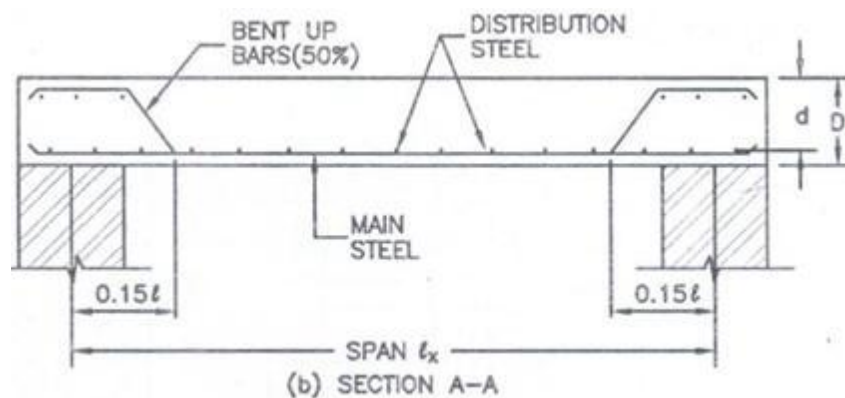

❖ **Two way slab:** When the slab is supported on four edges and the load distribution is also on four edges of the panel. The reinforcement is provided on both the sides. Such slab is known as two way slab.

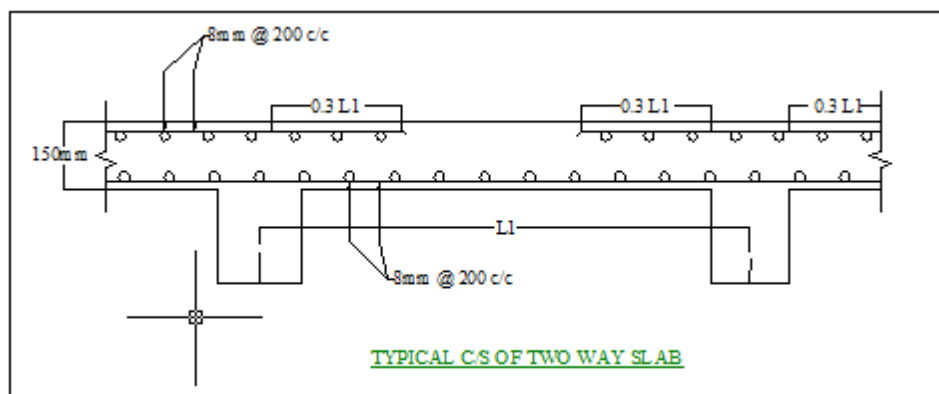

Design of beam : There are three types of reinforced concrete beams 1 Single reinforced beams 2 Double reinforced beams

❖ **Single reinforced beams:** In singly reinforced simply supported beams steel bars are placed near the bottom of the beam where they are effective in resisting in the tensile bending stress.

❖ **Double reinforced beams:** It is reinforced under compression tension regions. The necessities of steel of compression region arise due to two reasons. When depth of beam is restricted. The strength availability singly reinforced beam is in adequate.

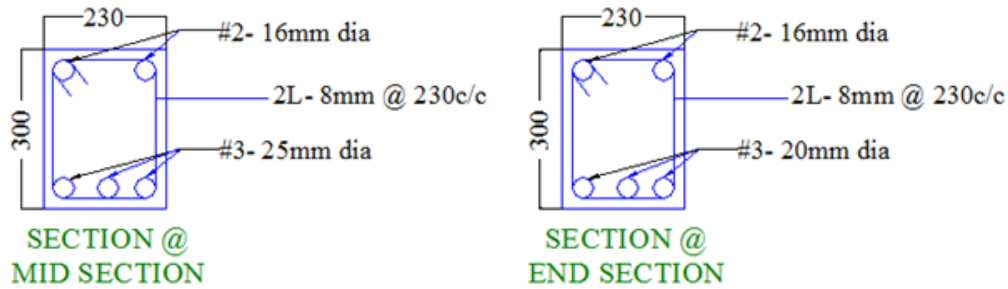

Beam reinforcement

COLUMN :A column may be defined as an element used primary to support axial compressive loads and with a height of a least three times its lateral dimension. The strength of column depends upon the strength of materials, shape and size of cross section, length and degree of proportional and dedicational restrains at its ends.

FOOTING :Foundations are structural elements that transfer loads from the building or individual column to the earth .If these loads are to be properly transmitted, foundations must be designed to prevent excessive settlement or rotation, to minimize differential settlement and to provide adequate safety against sliding and overturning.

Design of stair case : The purpose of a stair case to provide access to pedestrian in a building. The geometrical forms of staircase may be quite different depending on the individual circumstances involved. The shape and structural arrangement of a staircase would generally depend on two main factors.

1. Type of construction of structure around the stair case that is load bearing brick structure or reinforced concrete framed structure.
2. Availability of space.

Type of staircase provided for the proposed building is Bifurcated staircase, which consists of two flights. The first flight starts from plinth level to lintel level and second flight starts from lintel level to roof level.

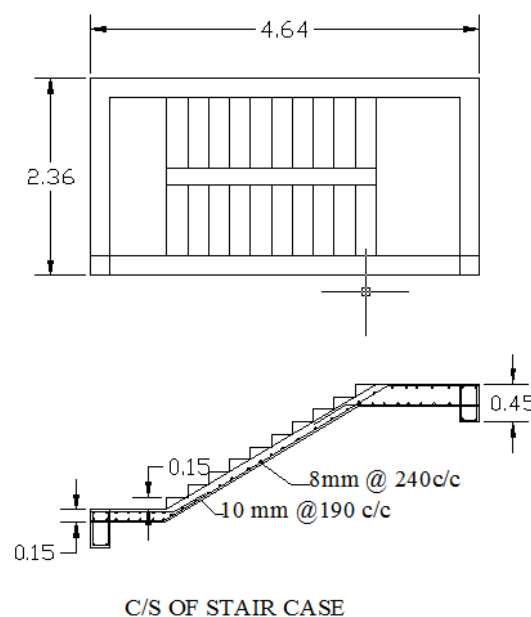

NEED

Construction of any structure inculcates a huge lot of humanwork , machinery , materials , time and for all these the money!

So before converting any design into actual structure , it is important to know whether the structure can with stand the various loads and disturbances .

Here is the field where staad comes to help .with it we can calculate the various deflection , bending moment , shear force , etc and before theactual construction we can conclude whether the structure would be a success or a fail .

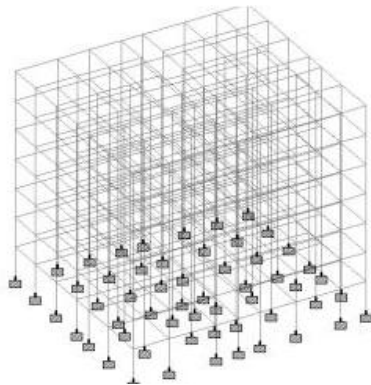

3d Modelling In Staad Pro

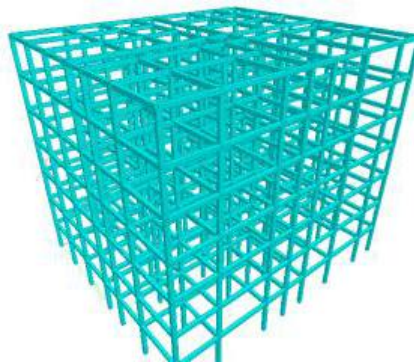

3d Rendering

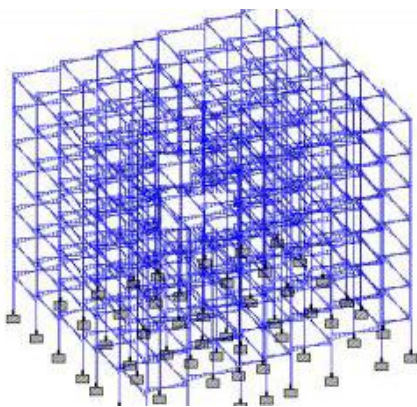

Shear Froce Diagram

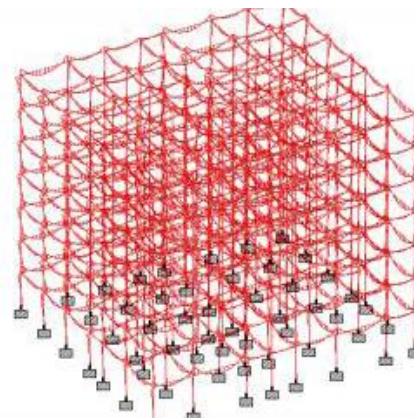

Bending Mmoment Diagram

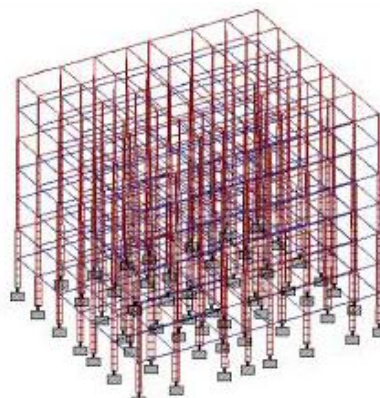

Axial Froce Diagram

SCOPE

- ❖ Elaborate designing and virtual testing of the structure to fine details .
- ❖ Detailed idea about the disruption and deflection that might come throughout the construction and after it .
- ❖ Avoiding of the deflection by proper calculation and designing .
- ❖ Easy implementation of the design on site .

III. CONCLUSIONS

1. Short term deflection of all horizontal members is within 20mm.
2. The structural components of the building are safe in shear and flexure.
3. Amount of steel provided for the structure is economic.
4. There is no such large difference in analysis results of STAAD Pro and Kanis method.
5. Proposed sizes of the elements can be used in the structure .

REFERENCES

- ❖ www.ijird.com
- ❖ civil.srpec.org.in
- ❖ www.ijettjournal.org

IS CODES :

- ❖ IS 456-2000 (Design of RCC structural elements)
- ❖ IS 875-Part 1 (Dead Load)
- ❖ IS 875-Part 2 (Live Load)
- ❖ SP-16 (Depth and Percentage of Reinforcement)
- ❖ SP-34 (Detailing)